

# Replacement Parts - TCH418-260 AKC Series

**NOTE:** This illustration is for reference only. The appearance of your unit may differ from the unit shown.

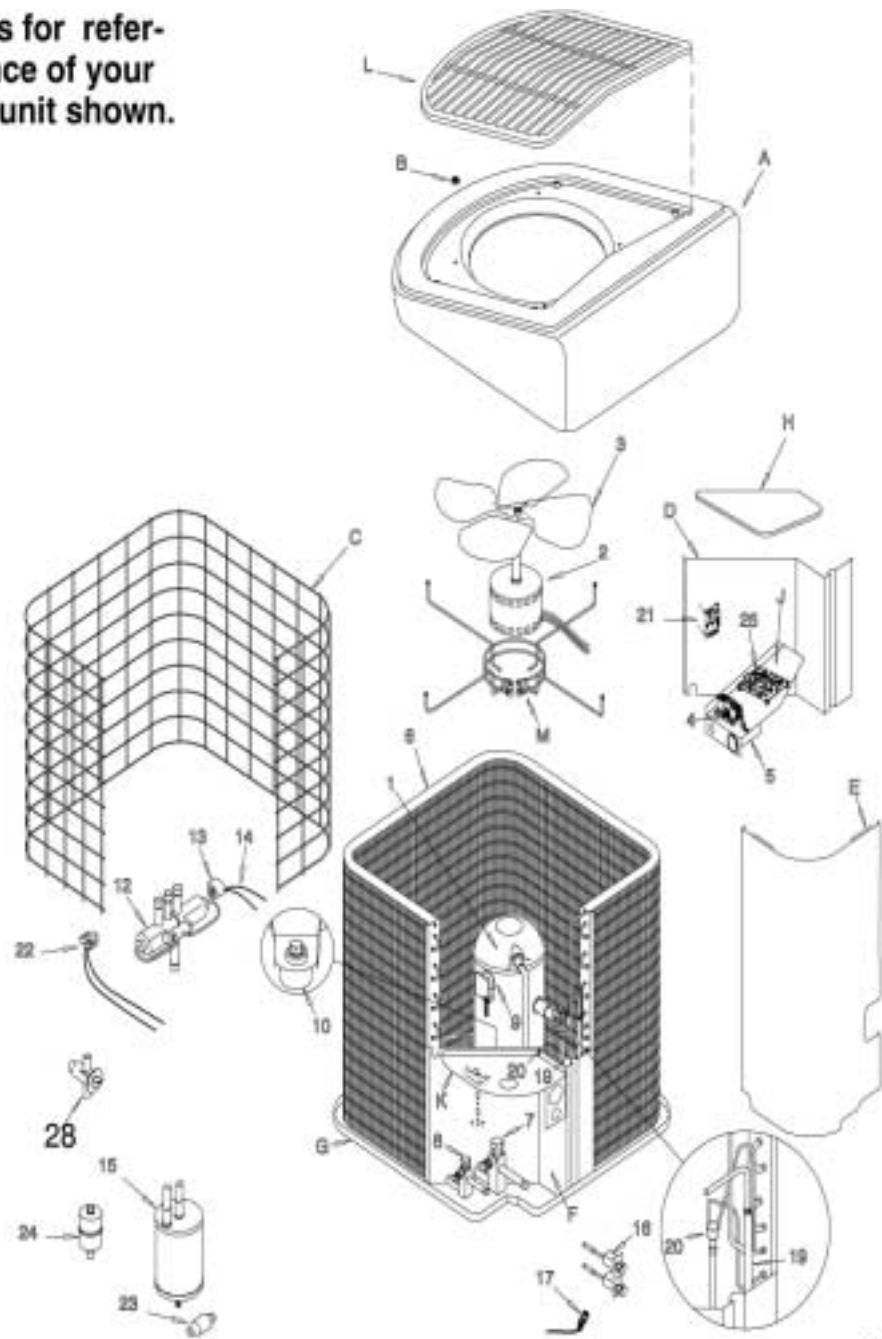

381119HA

# Replacement Parts - TCH418-260 AKC Series

KEY NO.	DESCRIPTION	PART NUMBER	TCH424AKC1	TCH430AKC1	TCH436AKC1	TCH442AKC1	TCH448AKC1	TCH460AKC1
1	Compressor	ZR22K4PFV130	1					
1		ZR28K3PFV130	-	1				
1		ZR34K3PFV130	-	-	1			
1		ZR36K3PFV130	-	-	-	1		
1		ZR42K3PFV130	-	-	-	-	1	
1		ZR54K3PFV130	-	-	-	-	-	1
2	Motor, Condenser Fan	1087624	1	1	1			
2		1086404	-	-	-	1	1	1
3	Fan Blade	1086513	1	1	1			
3		1087076	-	-	-	1		
3		1087077	-	-	-	-	1	
3		1087078	-	-	-	-	-	1
4	Contact, 25 Amp	1050699	1	1	1			
4	35 Amp	1050839	-	-	-	1	1	
4	40 Amp	1059574	-	-	-	-	-	1
5	Capacitor, 370 Volt 5+35 Mfd	1086638	1					
5	370 Volt 5+45 Mfd	1086640	-	1				
5	370 Volt 5+50 Mfd	1086644	-	-	1			
5	370 Volt 7.5+50 Mfd	1086646	-	-	-	1		
5	370 Volt 7.5+60 Mfd	1086649	-	-	-	-	1	
5	370 Volt 7.5+80 Mfd	1086650	-	-	-	-	-	1
6	Condenser Coil	1088706	1					
6		1088711	-	1				
6		1088667	-	-	1			
6		1087090	-	-	-	1		
6		1088684	-	-	-	-	1	1
7	Service Valve (Suction)	1087244	1	1	1			
7		1086805	-	-	-	1	1	1
8	Service Valve (Liquid)	1085989	1	1	1	1	1	1
9	Plug, Compressor Harness	1081940	1	1	1	1	1	1
10	Grommet, Compressor	1052060	4	4	4	4	4	4
12	Valve, Reversing	513542	1	1				
12		34329002	-	-	1	1		
12		34329030	-	-	-	-	1	1
13	Coil, Reversing Valve	34329055	1	1	1	1	1	1
14	Harness, Reversing Valve Coil	1066711	1	1	1	1	1	1
15	Accumulator	1081063	1	1	1	1		
15		1061328	-	-	-	-	1	1
16	Port Valve Asy	1080998	1	1	1	1	1	1
17	Switch, Low Pressure	1081019	1	1	1	1	1	1
20	Distributor	1172019	1					
20		1172020	-	1	-	1		
20		1172021	-	-	1			
20		1172022	-	-	-	-	1	1
21	Control, Defrost	1087953	1	1	1	1	1	1
22	Sensor, Defrost Control	1086579	1	1	1	1	1	1
23	Muffler	1059730	1	1	1	1	1	1
24	Drier	1064507	1	1	1	1	1	1
25	Control, 2 Speed Fan	1086071	1	1	1	1	1	1
28	Valve, Expansion	1088325	1					
28		1088330	-	1				
28		1088331	-	-	1			
28		1088332	-	-	-	1		
28		1088333	-	-	-	-	1	
28		1088334	-	-	-	-	-	1

# Replacement Parts - TCH418-260 AKC Series

KEY NO.	DESCRIPTION	PART NUMBER	TCH424AKC1	TCH430AKC1	TCH436AKC1	TCH442AKC1	TCH448AKC1	TCH460AKC1
A	Panel, Top	1086064	1	1	1	1	1	1
B	Nut, Flanged	1088180	4	4	4	4	4	4
C	Grille, Inlet	1086263	1					
C		1086264	-	1	1			
C		1086331	-	-	-	1	1	1
D	Box, Control	1087550	1	1	1	1	1	1
E	Cover, Control Box	1087541	1	1	1	1	1	1
F	Panel, Corner	1087534	1					
F		1087535	-	1	1			
F		1087540	-	-	-	1	1	1
G	Panel, Base	1086060	1	1	1	1	1	1
H	Top, Control Box	1086045	1	1	1	1	1	1
J	Shelf, Control Box	1087926	1	1				
J		1087925	-	-	1	1	1	1
K	Bottom, Control Box	1087470	1	1	1	1	1	1
L	Grille, Top Discharge	1086074	1	1	1	1	1	1
M	Mount, Motor	1086072	1	1	1	1	1	1
)	Manual, Parts List	428033104	1	1	1	1	1	1
)	Manual, Owners	428023001	1	1	1	1	1	1
)	Manual, Installation	421013203	1	1	1	1	1	1

# Replacement Parts - TCH418-260 AKC Series

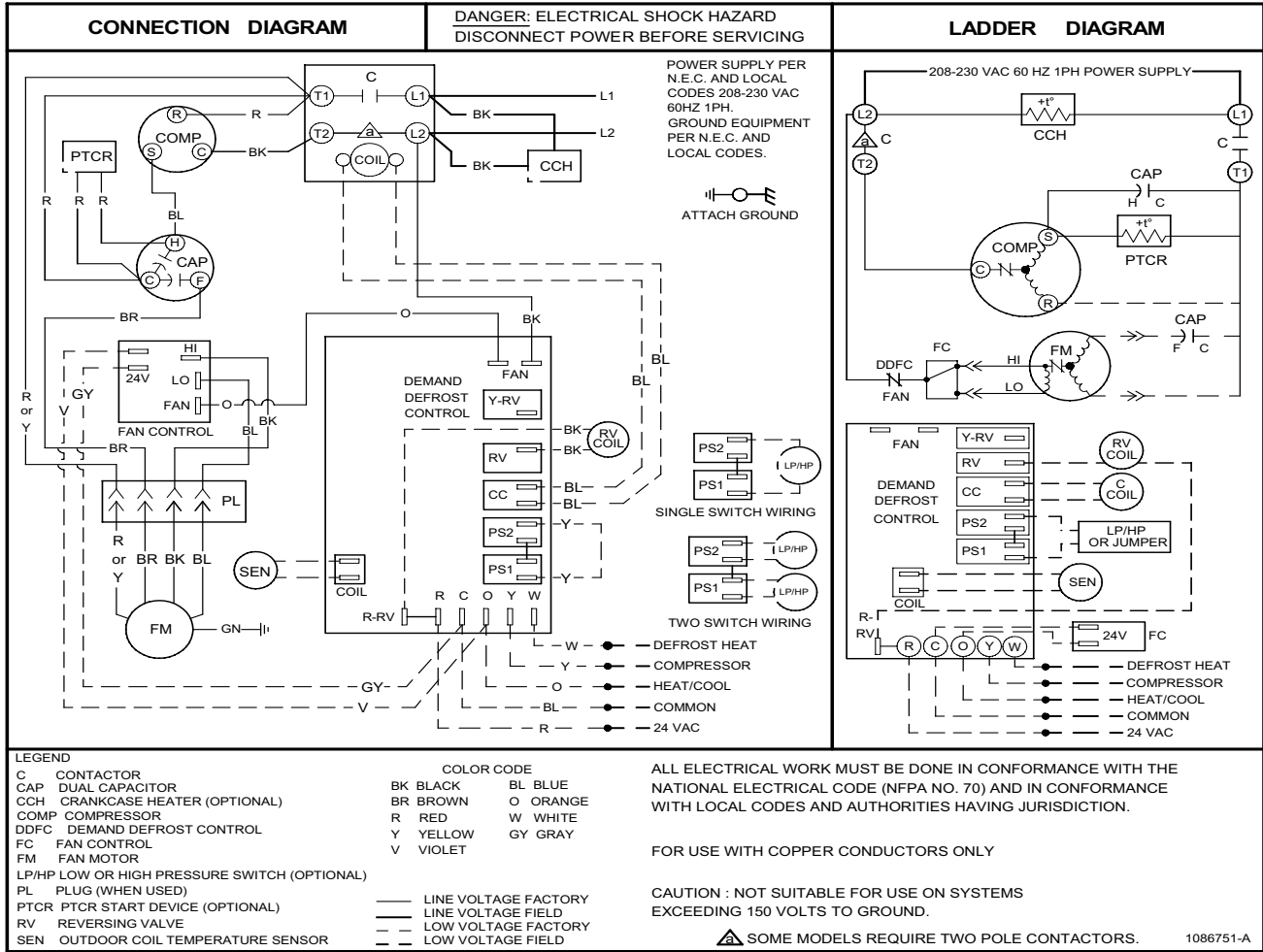

Style No:	TCH424AKC	Outdoor Ambient Temperature - Degrees F. Dry Bulb																								
		75					85					95					105					115				
		Entering Indoor Temperature - Degrees F. Wet Bulb																								
Voltage	208/230																									
Phase	1																									
Ampacity	14.4																									
Wire Ga/Ft	14 / 49																									
Delay Fuse	20																									
Max. Fuse	20																									
Compressor	SCROLL																									
RLA	10.9																									
LRA	54																									
Cap MFD/V	-																									
CC Heater	None																									
Start Kit	None																									
Fan Motor-HP	1/8																									
Type	PSC																									
FLA	0.8																									
LRA	1.5																									
RPM	840																									
Cap MFD/V	5/370																									
PTCR	None																									
Hi Press	225																									
Low Press	80																									
Low Amb	None																									
Defrost	Elec/Time-Temp																									
Sensor	31-71																									
Operating Chg (No Lines)*	(R-220z)																									
Service Driers																										
Liquid/Chg Suction	300 OZ																									
Unit Weight	284																									

IDB	Outdoor Ambient Temperature - Degrees F. Dry Bulb																								
	65					50					40					25					15				
	Heating																								
MBh	31	29	27	26	24	24	22	20	18	17	16	15	14	13	11	10	8	7							
T/R	35.5	33.6	31.7	29.6	28.2	27.4	25.4	23.4	21.3	19.7	18.1	17.1	16.5	14.8	13.1	11.4	9.8	8.0							
KW	2.2	2.2	2.1	2.1	2.1	2.0	2.0	2.0	2.0	1.9	1.9	1.9	1.8	1.8	1.7	1.7	1.7	1.6							
AMPS	11.2	10.4	9.8	9.3	9.0	8.8	8.3	8.0	7.7	7.4	7.0	6.9	6.8	6.5	6.1	5.8	5.4	5.0							
COP	4.05	3.91	3.76	3.59	3.47	3.39	3.22	3.04	2.74	2.59	2.44	2.34	2.27	2.09	1.90	1.70	1.49	1.26							
EER	13.8	13.4	12.9	12.3	11.9	11.6	11.0	10.4	9.4	8.8	8.3	8.0	7.8	7.1	6.5	5.8	5.1	4.3							
HI PR	267	256	246	236	230	226	217	208	199	190	183	178	175	169	162	155	150	145							
LO PR	80	74	69	63	60	58	53	47	43	38	33	31	30	25	22	18	16	13							

Calculated averaged performance data, for service applications for all matches. Part No: 1088867

\*Add or Subtract (Oz per Ft) for Lines: .25oz - 1/4 Liq, .45oz - 5/16 Liq, .60oz - 3/8 Liq, 1.2 oz - 1/2 Liq

# Replacement Parts - TCH418-260 AKC Series

Style No:	TCH430AKC	Outdoor Ambient Temperature - Degrees F. Dry Bulb																			
		75				85				95				105				115			
		Entering Indoor Temperature - Degrees F. Wet Bulb																			
	IDB	59	63	67	71	59	63	67	71	59	63	67	71	59	63	67	71	59	63	67	71
Voltage	208/230																				
Phase	1																				
Ampacity	18.4																				
Wire Ga/Ft	14 / 39																				
Delay Fuse	30																				
Max. Fuse	30																				
Compressor	SCROLL																				
RLA	14.1																				
LRA	72.5																				
Cap MFD/V	--																				
CC Heater	None																				
Start Kit	None																				
Fan Motor-HP	1/8																				
Type	PSC																				
FLA	0.8																				
LRA	1.5																				
RPM	840																				
Cap MFD/V	5/370																				
PTCR	None	Heating																			
Hi Press	228	IDB																			
Low Press	73	65 60 55 50 47 45 40 35 30 25 20 17 15 10 5 0 -5 -10																			
Low Amb	None																				
Defrost	ElecTime-Temp																				
Sensor	31-71																				
Operating Chg (No Lines)*	(R-22Oz)																				
Service Driers																					
Liquid/Chg	292 OZ																				
Suction																					
Unit Weight	299	Calculated averaged performance data, for service applications for all matches.																			

Part No: 1088868  
\*Add or Subtract (Oz per Ft) for Lines: .25oz -1/4 Liq, .45oz- 5/16 Liq, .60oz - 3/8 Liq, 1.2 oz - 1/2 Liq

Style No:	TCH436AKC	Outdoor Ambient Temperature - Degrees F. Dry Bulb																			
		75				85				95				105				115			
		Entering Indoor Temperature - Degrees F. Wet Bulb																			
	IDB	59	63	67	71	59	63	67	71	59	63	67	71	59	63	67	71	59	63	67	71
Voltage	208/230																				
Phase	1																				
Ampacity	20.8																				
Wire Ga/Ft	12 / 54																				
Delay Fuse	30																				
Max. Fuse	30																				
Compressor	SCROLL																				
RLA	16																				
LRA	88																				
Cap MFD/V	--																				
CC Heater	None																				
Start Kit	None																				
Fan Motor-HP	1/8																				
Type	PSC																				
FLA	0.8																				
LRA	1.5																				
RPM	840																				
Cap MFD/V	5/370																				
PTCR	None	Heating																			
Hi Press	240	IDB																			
Low Press	76	65 60 55 50 47 45 40 35 30 25 20 17 15 10 5 0 -5 -10																			
Low Amb	None																				
Defrost	ElecTime-Temp																				
Sensor	31-71																				
Operating Chg (No Lines)*	(R-22Oz)																				
Service Driers																					
Liquid/Chg	330 OZ																				
Suction																					
Unit Weight	311	Calculated averaged performance data, for service applications for all matches.																			

Part No: 1088869  
\*Add or Subtract (Oz per Ft) for Lines: .25oz -1/4 Liq, .45oz- 5/16 Liq, .60oz - 3/8 Liq, 1.2 oz - 1/2 Liq

# Replacement Parts - TCH418-260 AKC Series

Style No:	TCH442AKC	Outdoor Ambient Temperature - Degrees F. Dry Bulb																			
		75				85				95				105				115			
		Entering Indoor Temperature - Degrees F. Wet Bulb																			
IDB		59	63	67	71	59	63	67	71	59	63	67	71	59	63	67	71	59	63	67	71
Voltage	208/230																				
Phase	1																				
Ampacity	27.4																				
Wire Ga/Ft	10 / 66																				
Delay Fuse	40																				
Max. Fuse	40																				
Compressor	SCROLL																				
RLA	20.7																				
LRA	95																				
Cap MFD/V	--																				
CC Heater	None																				
Start Kit	None																				
Fan Motor-HP	1/4																				
Type	PSC																				
FLA	1.5																				
LRA	2.9																				
RPM	840																				
Cap MFD/V	5/370																				
PTCR	None																				
Hi Press	254																				
Low Press	81																				
Low Amb	None																				
Defrost	ElecTime-Temp																				
Sensor	31-71																				
Operating Chg (No Lines)*	(R-22Oz)																				
Service Driers																					
Liquid/Chg	375 OZ																				
Suction																					
Unit Weight	319																				

Style No:	TCH448AKC	Outdoor Ambient Temperature - Degrees F. Dry Bulb																			
		75				85				95				105				115			
		Entering Indoor Temperature - Degrees F. Wet Bulb																			
IDB		59	63	67	71	59	63	67	71	59	63	67	71	59	63	67	71	59	63	67	71
Voltage	208/230																				
Phase	1																				
Ampacity	26.6																				
Wire Ga/Ft	10 / 68																				
Delay Fuse	40																				
Max. Fuse	40																				
Compressor	SCROLL																				
RLA	20.1																				
LRA	109																				
Cap MFD/V	--																				
CC Heater	None																				
Start Kit	None																				
Fan Motor-HP	1/4																				
Type	PSC																				
FLA	1.5																				
LRA	2.9																				
RPM	3900																				
Cap MFD/V	5/370																				
PTCR	None																				
Hi Press	232																				
Low Press	83																				
Low Amb	None																				
Defrost	ElecTime-Temp																				
Sensor	31-71																				
Operating Chg (No Lines)*	(R-22Oz)																				
Service Driers																					
Liquid/Chg	333 OZ																				
Suction																					
Unit Weight	329																				

\*Add or Subtract (Oz per Ft) for Lines: .25oz -1/4 Liq., .45oz- 5/16 Liq., .60oz- 3/8 Liq, 1.2 oz - 1/2 Liq

Part No: 1088870

# Replacement Parts - TCH418-260 AKC Series

Style No:	TCH460AKC	Outdoor Ambient Temperature - Degrees F. Dry Bulb																					
		75				85				95				105				115					
		Entering Indoor Temperature - Degrees F. Wet Bulb																					
Voltage	208/230	IDB	59	63	67	71	59	63	67	71	59	63	67	71	59	63	67	71	59	63	67	71	
Phase	1		MBh	54	56	60	65	53	54	59	63	52	53	57	62	49	50	55	59	45	47	51	54
Ampacity	36.5	75	S/T	0.84	0.75	0.57	0.36	0.86	0.77	0.58	0.37	0.88	0.79	0.60	0.38	0.92	0.82	0.62	0.40	0.93	0.83	0.63	0.40
Wire Ga/Ft	8 / 77		AMPS	18.7	19.1	19.7	20.4	20.2	20.6	21.3	22.0	21.5	21.9	22.6	23.4	22.7	23.2	23.9	24.8	24.0	24.5	25.3	26.2
Delay Fuse	60		HI PR	176	189	199	208	200	215	227	237	227	245	258	270	256	275	291	303	283	304	321	335
Max. Fuse	60		LO PR	61	65	71	75	63	67	74	78	66	71	77	82	70	74	81	86	72	77	84	89
Compressor	SCROLL	80	MBh	55	56	60	64	54	55	59	63	52	54	57	61	50	51	54	58	46	47	50	54
RLA	28		S/T	0.92	0.86	0.70	0.52	0.94	0.88	0.72	0.54	0.97	0.91	0.74	0.55	1.00	0.94	0.77	0.57	1.00	0.95	0.77	0.58
LRA	169		AMPS	18.9	19.3	19.9	20.6	20.4	20.8	21.4	22.2	21.6	22.1	22.8	23.6	22.9	23.4	24.2	25.0	24.2	24.7	25.5	26.4
Cap MFD/V	--		HI PR	177	191	201	210	202	217	229	239	230	247	261	272	258	278	294	306	285	307	324	338
CC Heater	None	85	LO PR	62	65	71	76	64	68	74	79	67	71	78	83	70	75	82	87	73	77	85	90
Start Kit	None		MBh	56	57	60	64	55	56	58	62	53	54	57	61	51	52	54	58	47	48	50	54
Fan Motor-HP	1/4		S/T	0.96	0.93	0.84	0.68	0.98	0.95	0.86	0.70	1.00	0.98	0.89	0.72	1.00	1.00	0.92	0.75	1.00	1.00	0.93	0.75
Type	PSC		AMPS	19.1	19.5	20.0	20.7	20.5	21.0	21.6	22.4	21.8	22.3	23.0	23.8	23.1	23.6	24.4	25.2	24.4	24.9	25.7	26.6
FLA	1.5	70	HI PR	179	193	204	212	204	219	231	241	232	250	264	275	261	281	297	309	288	310	328	342
LRA	2.9		LO PR	62	66	72	77	65	69	75	80	68	72	79	84	71	76	83	88	74	78	85	91
RPM	4000		Outdoor Ambient Temperature - Degrees F. Dry Bulb																				
Cap MFD/V	5/370	Heating IDB	65	60	55	50	47	45	40	35	30	25	20	17	15	10	5	0	-5	-10			
PTCR	None		MBh	74	70	66	62	59	57	53	49	47	43	40	38	36	33	29	25	22	18		
Hi Press	261	70	T/R	39.4	37.3	35.1	32.8	31.3	30.4	28.2	26.0	24.9	23.0	21.2	20.0	19.3	17.3	15.3	13.4	11.4	9.3		
Low Press	78		KW	5.5	5.4	5.3	5.2	5.1	5.1	4.9	4.8	5.2	5.1	5.0	4.9	4.9	4.7	4.6	4.5	4.4	4.2		
Low Amb	None		AMPS	27.8	25.9	24.3	23.0	22.2	21.8	20.7	19.7	18.9	18.1	17.4	17.0	16.8	16.0	15.1	14.3	13.3	12.2		
Defrost	ElecTime-Temp		COP	3.96	3.82	3.68	3.51	3.40	3.32	3.15	2.97	2.64	2.49	2.35	2.26	2.19	2.02	1.84	1.65	1.45	1.22		
Sensor	31-71	70	EER	13.5	13.1	12.6	12.0	11.6	11.3	10.8	10.2	9.0	8.5	8.0	7.7	7.5	6.9	6.3	5.6	4.9	4.2		
Operating Chg (No Lines)*	(R-22Oz)		HI PR	287	275	265	253	247	242	233	224	214	205	196	192	188	181	174	167	161	155		
Service Driers	400 OZ		LO PR	73	68	63	58	55	53	49	43	39	35	31	29	28	23	20	17	15	12		
Liquid/Chg Suction		346	Calculated averaged performance data, for service applications for all matches.																				
Unit Weight	346	*Add or Subtract (Oz per Ft) for Lines: .25oz -1/4 Liq, .45oz- 5/16 Liq, .60oz - 3/8 Liq, 1.2 oz - 1/2 Liq																					

Part No:

1088872