

# Parts List, Charging Chart, Tech Labels, Wiring Diagrams

**PHT324 - PHT360 Single Phase**

**PACKAGE HEAT PUMP UNITS**

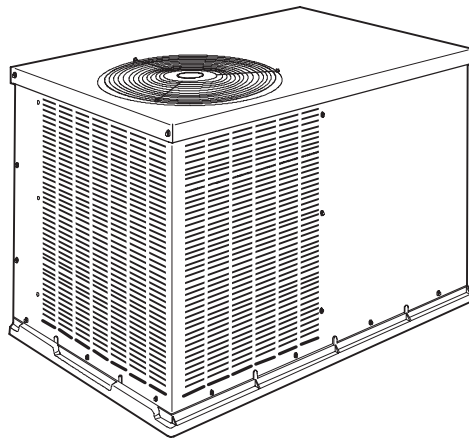

## TABLE OF CONTENTS

<b>PARTS LIST</b> .....	<b>2-4</b>
<b>PARTS DRAWING</b> .....	<b>5-7</b>
<b>CHARGING CHARTS</b> .....	<b>8-9</b>
<b>TECH LABELS</b>	
<b>PHT324</b> .....	<b>10</b>
<b>PHT330</b> .....	<b>11</b>
<b>PHT336</b> .....	<b>12</b>
<b>PHT342</b> .....	<b>13</b>
<b>PHT348</b> .....	<b>14</b>
<b>PHT360</b> .....	<b>15</b>
<b>WIRING DIAGRAMS</b> .....	<b>16-17</b>



**PHT324 - PHT360 1Phase PARTS LIST**

KEY NO.	DESCRIPTION	FAST PART NO.	PHT324K00A1	PHT330K00A1	PHT336K00A1	PHT342K00A1	PHT348K00A1	PHT360K00A1
01	COMP ZR22K4-PFV-130	ZR22K4PFV130	1	*	*	*	*	*
01	COMP ZR28K3-PFV-130	ZR28K3PFV130	*	1	*	*	*	*
01	COMP ZR34K3-PFV-130	ZR34K3PFV130	*	*	1	*	*	*
01	COMP ZR40K3-PFV-130	ZR40K3PFV130	*	*	*	1	*	*
01	COMP ZR42KA-PFV-130	ZRS43K4PFV130	*	*	*	*	1	*
01	COMP ZRS52K4-PFV-130	ZRS52K4PFV130	*	*	*	*	*	1
02	CAP RN RD 370V 5+35	1172110	1	*	*	*	*	*
02	CAP RN RD 370V 5+45	1172124	*	1	*	*	*	*
02	CAP RN RD 370V 5+50	1172111	*	*	1	*	*	*
02	CAP RN RD 370V 5+55	1172123	*	*	*	1	*	*
02	CAP RN RD 370V 45+10	1173702	*	*	*	*	1	*
02	CAP RN RD 370V 80+10	1173703	*	*	*	*	*	1
03	CIRCUIT BOARD X-13	1173692	1	1	1	1	*	*
03	CIRCUIT BOARD X-11	1173692	*	*	*	*	1	1
04	CONTACTOR 1P 25A 24V	1173689	1	1	1	1	*	*
04	CONTACTOR 1P 25A 24V	1173690	*	*	*	*	1	1
05	TRANS 200/230/460>24 75VA	1171496	1	1	1	1	1	1
07	MTR CND 1/230 1/8 825/1	1173699	1	1	*	*	*	*
07	MTR CND 1/230 1/4 1100/1	1173700	*	*	1	1	*	*
07	MTR CND 1/230 1/4	1171335	*	*	*	*	1	*
07	MTR CND 1/2HP 1/230 1100/1SPD	1173701	*	*	*	*	*	1
08	FAN C 20" 3B 1/2" 34 INT	1173706	1	1	1	1	1	*
08	FAN C 20" 4B 1/2" 34 INT	1173707	*	*	*	*	*	1
09	WHEEL DD10x8x1/2 CW CV	1173813	1	1	*	*	*	*
09	WHEEL DD11x9x1/2 CW CV	1171742	*	*	1	1	*	*
09	WHEEL DD11x10x1/2 CW CV	1173815	*	*	*	*	1	1
10	MTR BLT 1/208-230 1/2 600-1200	1176452	1	1	*	*	*	*
10	MTR BLT 1/208-230 3/4 600-1200	1176460	*	*	1	1	*	*
10	MTR BLT 1/208-230 1 600-1200	1176468	*	*	*	*	1	*
10	MTR BLT 1/208-230 1 600-1200	1176474	*	*	*	*	*	1
11	COIL ASY COND AL/CU	1176481	1	*	*	*	*	*
11	COIL ASY COND AL/CU	1176483	*	1	*	*	*	*
11	COIL ASY COND AL/CU	1176484	*	*	1	*	*	*
11	COIL ASY COND AL/CU	1176485	*	*	*	1	*	*
11	COIL ASY COND AL/CU	1176486	*	*	*	*	1	*
11	COIL ASY COND AL/CU	1176490	*	*	*	*	*	1
12	COIL ASY EVAP AL/CU (STANDARD)	1176454	1	*	*	*	*	*
12	COIL ASY EVAP AL/CU (STANDARD)	1176456	*	1	*	*	*	*
12	COIL ASY EVAP AL/CU (STANDARD)	1176461	*	*	1	*	*	*
12	COIL ASY EVAP AL/CU (STANDARD)	1176464	*	*	*	1	*	*
12	COIL ASY EVAP AL/CU (STANDARD)	1176470	*	*	*	*	1	*
12	COIL ASY EVAP AL/CU (STANDARD)	1176475	*	*	*	*	*	1
13	COIL ASY EVAP AL/CU TIN PLATED (OPTIONAL)	1176455	1	*	*	*	*	*
13	COIL ASY EVAP AL/CU TIN PLATED (OPTIONAL)	1176459	*	1	*	*	*	*

**PHT324 - PHT360 1Phase PARTS LIST (continued)**

KEY NO.	DESCRIPTION	FAST PART NO.	PHT324K00A1	PHT330K00A1	PHT336K00A1	PHT342K00A1	PHT348K00A1	PHT360K00A1
13	COIL ASY EVAP AL/CU TIN PLATED (OPTIONAL)	1176463	*	*	1	*	*	*
13	COIL ASY EVAP AL/CU TIN PLATED (OPTIONAL)	1176466	*	*	*	1	*	*
13	COIL ASY EVAP AL/CU TIN PLATED (OPTIONAL)	1176472	*	*	*	*	1	*
13	COIL ASY EVAP AL/CU TIN PLATED (OPTIONAL)	1176477	*	*	*	*	*	1
14	PISTON CHATLEFF .067	1173867	1	1	*	*	*	*
14	PISTON CHATLEFF .082	1173870	*	*	1	*	*	*
14	PISTON CHATLEFF .086	1173872	*	*	*	1	*	*
15	DISTRIBUTOR 5 CIRCUIT	1174242	1	*	*	1	*	*
15	DISTRIBUTOR 3 CIRCUIT	1174241	*	1	*	*	*	*
15	DISTRIBUTOR 6 CIRCUIT	1174245	*	*	1	*	*	*
15	DISTRIBUTOR 6 CIRCUIT	1175220	*	*	*	*	1	*
15	DISTRIBUTOR 6 CIRCUIT	1175185	*	*	*	*	*	1
16	TAILPIECE KIT	1174325	2	2	2	2	2	2
17	BLW MTR MOUNTING HDWR KIT	1174295	1	1	1	1	1	1
18	HTR CC WP 40W/240V	1173705	*	1	1	1	1	1
19	VALVE TXV 4.0 BI-FLO R22	1176478	*	*	*	*	1	*
19	VALVE TXV 6.0 BI-FLO R22	1176479	*	*	*	*	*	1
20	SWITCH PRESS HI O355 C285	1173712	*	*	*	*	1	1
21	BREAKER 3.2A 1 POLE 250V	1171114	1	1	1	1	1	1
22	VALVE REV W/COIL 24V	1173708	1	1	1	*	*	*
22	VALVE REV W/COIL 24V	1172618	*	*	*	1	1	*
22	VALVE REV W/COIL 24V	1173709	*	*	*	*	*	1
23	ACCUMULATOR 120 IN3 3/4	1172018	1	1	1	*	*	*
23	ACCUMULATOR 154 IN3 3/4	1173713	*	*	*	1	*	*
23	ACCUMULATOR 174 IN3 7/8	1173714	*	*	*	*	1	*
23	ACCUMULATOR 216 IN3 7/8	1172327	*	*	*	*	*	1
24	PRESSURE SWITCH	1175308	1	1	1	1	1	1
25	TEMPERATURE SWITCH	1176480	1	1	1	1	1	1
26	BOARD DEFROST	1174185	1	1	1	1	1	1
27	DISTRIBUTOR 4 CIRCUIT	1174446	1	*	*	*	*	*
27	DISTRIBUTOR 5 CIRCUIT	1174242	*	1	1	1	1	*
27	DISTRIBUTOR 6 CIRCUIT	1174245	*	*	*	*	*	1
28	PISTON CHATLEFF .049	1173868	1	*	*	*	*	*
28	PISTON CHATLEFF .057	1173658	*	1	*	*	*	*
28	PISTON CHATLEFF .059	1173871	*	*	1	*	*	*
28	PISTON CHATLEFF .063	1174003	*	*	*	1	*	*
28	PISTON CHATLEFF .070	1173869	*	*	*	*	1	*
28	PISTON CHATLEFF .073	1174017	*	*	*	*	*	1
29	COIL REV VLV 24V	1172619	1	1	1	1	1	1
A	OUTLET GRILLE	1173832	1	1	1	1	1	1
B	BASE PAN ASY	1176607	1	1	1	1	1	1
C	ACCESS PANEL	1176608	1	*	*	*	*	*
C	ACCESS PANEL	1176615	*	1	*	*	*	*
C	ACCESS PANEL	1176616	*	*	1	1	1	1

**PHT324 - PHT360 1Phase PARTS LIST (continued)**

KEY NO.	DESCRIPTION	FAST PART NO.	PHT324K00A1	PHT330K00A1	PHT336K00A1	PHT342K00A1	PHT348K00A1	PHT360K00A1
D	TOP COVER ASY	1176609	1	1	1	1	1	1
E	FLANGE (DUCT)	1174176	2	2	2	2	2	2
F	ACCESS PANEL	1176610	1	*	*	*	*	*
F	ACCESS PANEL	1176617	*	1	*	*	*	*
F	ACCESS PANEL	1176618	*	*	1	1	1	1
G	ELECTRICAL PANEL	1176611	1	*	*	*	*	*
G	ELECTRICAL PANEL	1176619	*	1	*	*	*	*
G	ELECTRICAL PANEL	1176620	*	*	1	1	1	1
H	LOUVERED SIDE PANEL	1176612	1	*	*	*	*	*
H	LOUVERED SIDE PANEL	1176621	*	1	*	*	*	*
H	LOUVERED SIDE PANEL	1176622	*	*	1	1	*	1
H	LOUVERED SIDE PANEL	1176623	*	*	*	*	1	*
J	GROMMET	1176613	1	1	1	1	1	1
K	GROMMET	1171737	1	1	1	1	1	1
L	CONDUIT	1173642	1	1	1	1	1	1
M	BRACKET	1174169	1	1	1	1	1	1
N	GROMMET	1171270	4	4	4	4	4	4
P	SLEEVE	1176614	4	4	4	4	4	4
Q	BLW HOUSING ASY	1174296	1	1	*	*	*	*
Q	BLW HOUSING ASY	1174307	*	*	1	1	*	*
Q	BLW HOUSING ASY	1174324	*	*	*	*	1	1
R	HOUSING BLOWER	1174166	1	1	*	*	*	*
R	HOUSING BLOWER	1174166	*	*	1	1	*	*
R	HOUSING BLOWER	1174168	*	*	*	*	1	1
S	DUCT WRAPPER ASY	1176633	1	*	*	*	*	*
S	DUCT WRAPPER ASY	1176634	*	1	*	*	*	*
S	DUCT WRAPPER ASY	1176635	*	*	1	1	1	1
PARTS NOT SHOWN								
)	HARNESS ASY	1176482	1	1	1	1	*	*
)	HARNESS ASY	1176487	*	*	*	*	1	1
)	HARNESS ASY	1174320	*	*	*	*	1	1
)	TOUCH-UP PAINT(16-OZ CAN)(STERLING GRAY)	1171357	1	1	1	1	1	1
)	PLUG ASY COMP	1175960	1	1	1	1	1	1

NOTE: This illustration is for reference only. Your unit may differ in appearance or may not include all components shown.

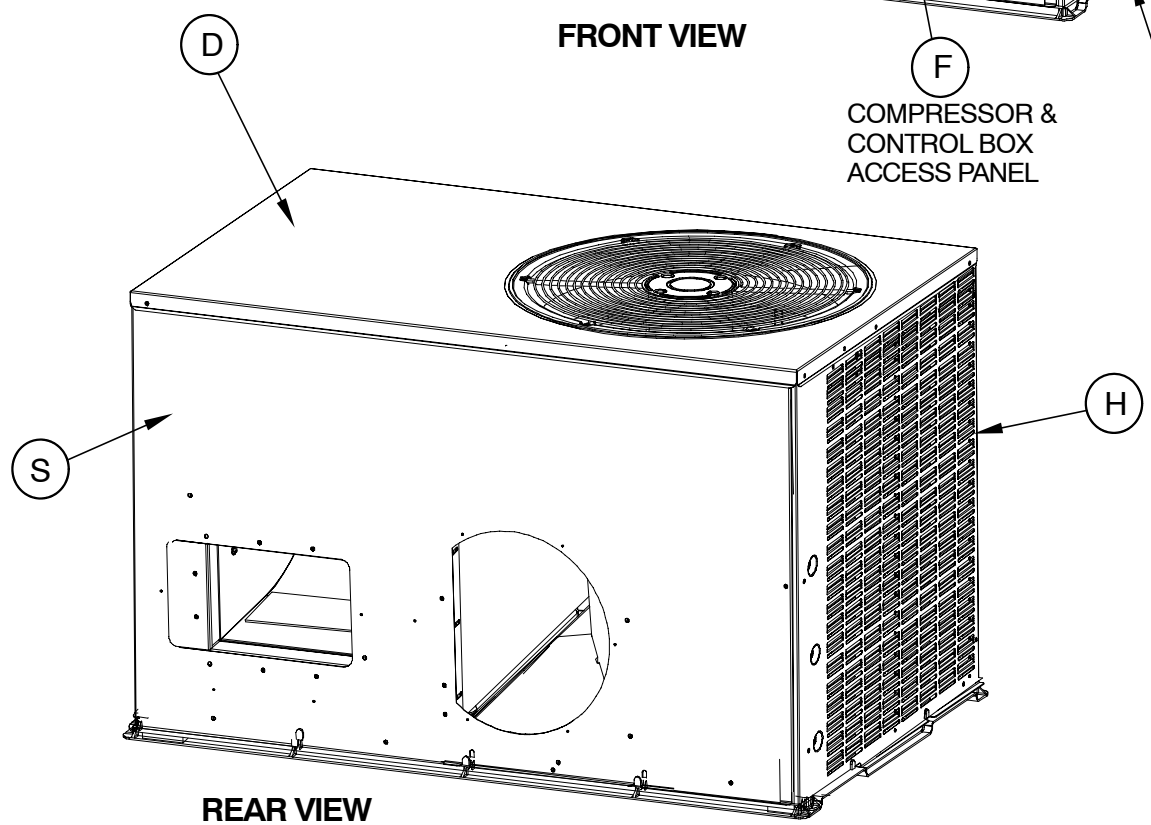
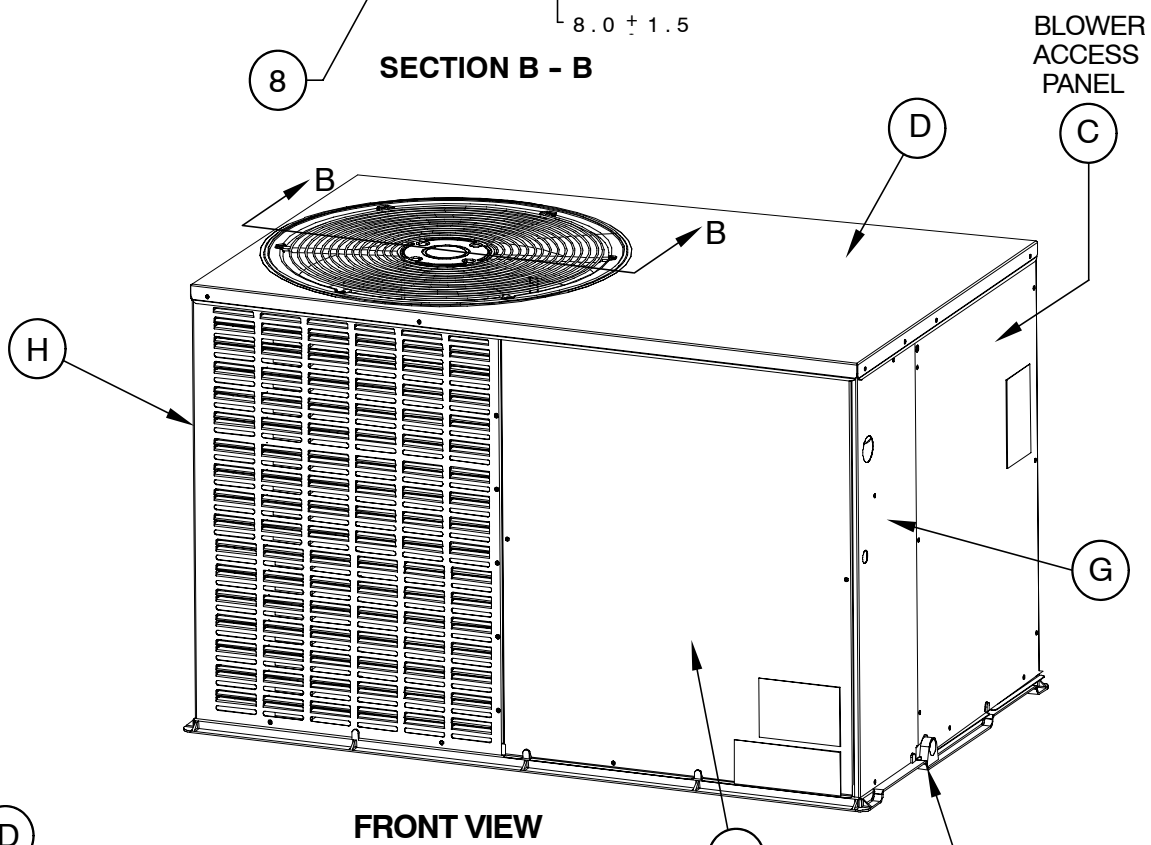
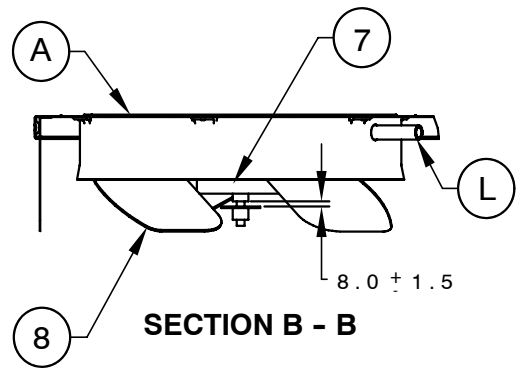

BLOWER ACCESS PANEL

FRONT VIEW

REAR VIEW

COMPRESSOR & CONTROL BOX ACCESS PANEL

CONDENSATE DRAIN CONNECTION

PHT324 - PHT360

NOTE: This illustration is for reference only. Your unit may differ in appearance or may not include all components shown.

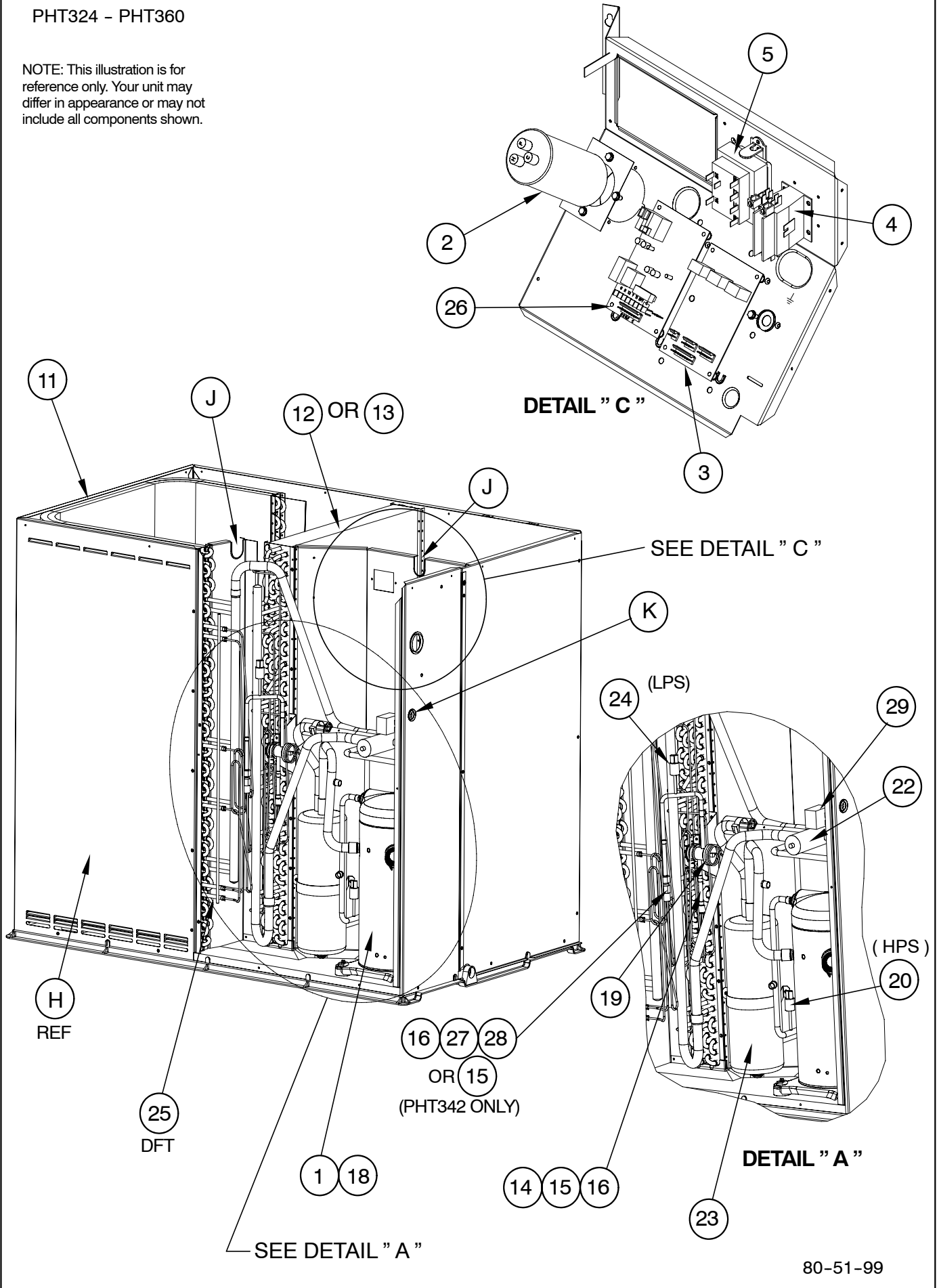

80-51-99

PHT324 - PHT360

NOTE: This illustration is for reference only. Your unit may differ in appearance or may not include all components shown.

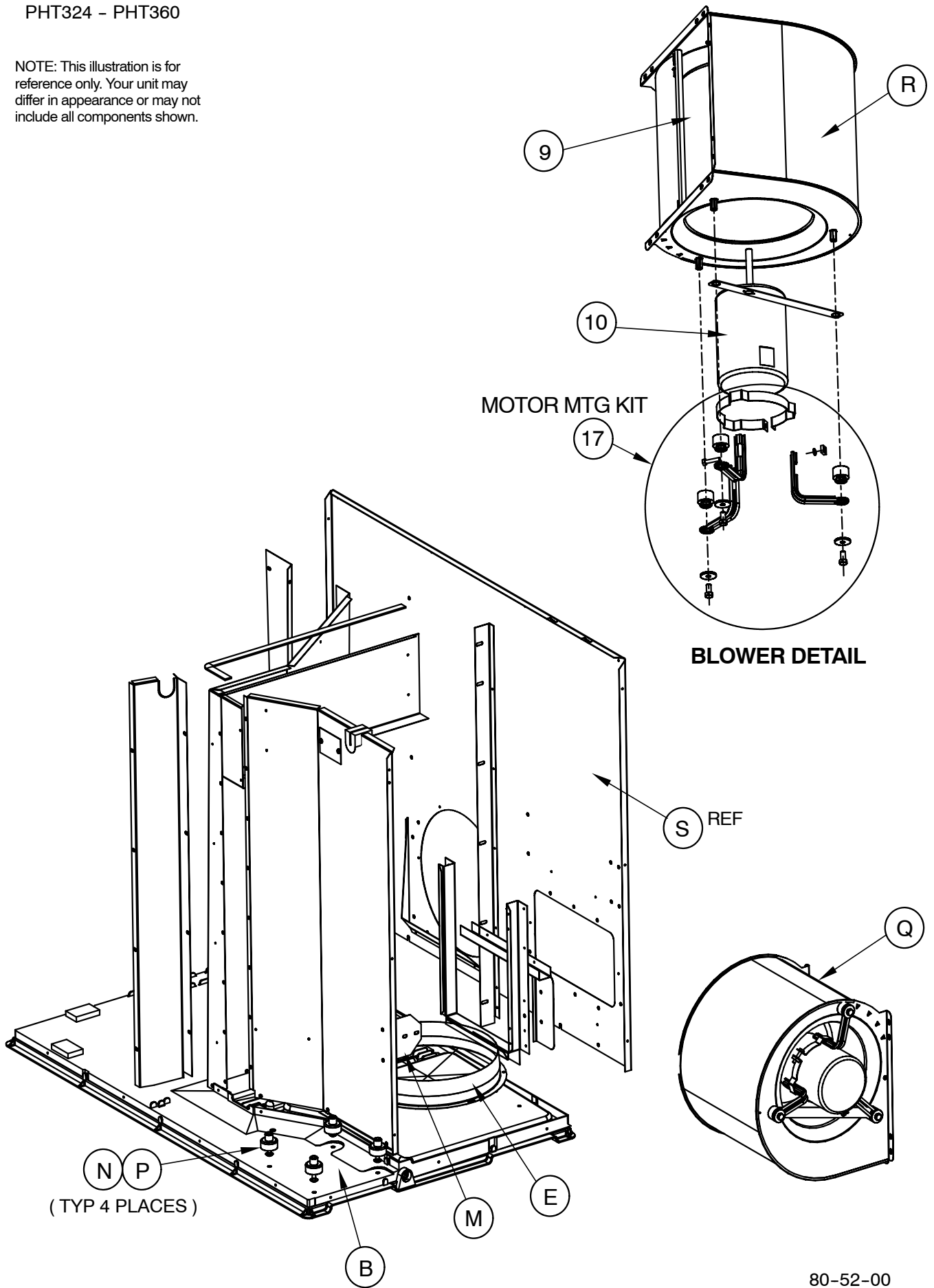

80-52-00

Suction Line Temperature (°F)															
OD Temp. (°F)	Suction Line Pressure (PSIG)														
	52	54	56	59	61	64	67	70	73	76	79	82	85	89	92
45	51	55	60	64	69	-	-	-	-	-	-	-	-	-	-
55	-	-	53	57	62	66	70	-	-	-	-	-	-	-	-
65	-	-	-	-	53	57	62	66	71	75	-	-	-	-	-
75	-	-	-	-	-	-	-	56	61	66	71	76	-	-	-
85	-	-	-	-	-	-	-	-	53	58	63	67	72	-	-
95	-	-	-	-	-	-	-	-	-	50	54	58	62	66	-
105	-	-	-	-	-	-	-	-	-	-	50	53	57	60	64
115	-	-	-	-	-	-	-	-	-	-	49	52	55	58	61
125	-	-	-	-	-	-	-	-	-	-	-	50	53	56	59

Suction Line Temperature (°C)															
OD Temp. (°C)	Suction Line Pressure (kPa)														
	361	370	387	405	423	442	462	482	502	523	544	566	589	612	636
7	11	13	15	18	21	-	-	-	-	-	-	-	-	-	-
13	-	-	12	14	16	19	21	-	-	-	-	-	-	-	-
18	-	-	-	-	12	14	17	19	21	24	-	-	-	-	-
24	-	-	-	-	-	-	-	13	16	19	22	24	-	-	-
29	-	-	-	-	-	-	-	-	12	14	17	20	22	-	-
35	-	-	-	-	-	-	-	-	-	10	12	14	17	19	-
41	-	-	-	-	-	-	-	-	-	-	10	12	14	16	18
46	-	-	-	-	-	-	-	-	-	-	9	11	13	14	16
52	-	-	-	-	-	-	-	-	-	-	-	10	11	13	15



Required Subcooling °F (°C)		Required Liquid Line Temperature for a Specific Subcooling (R-22)														
		Outdoor Ambient Temperature °F (°C)			Pressure (PSIG)		Required Subcooling (°F)						Pressure (kPa)		Required Subcooling (°C)	
Model Size	75 (24)	85 (29)	95 (35)	105 (41)	5	10	15	20	25	3	6	8	11	14		
PHT348	18 (10)	17 (9.4)	16 (8.9)	14 (7.8)	134	71	66	61	56	51	924	22	19	16	13	11
PAT348	24 (13.3)	22 (12.2)	22 (12.2)	20 (11.1)	141	74	69	64	59	54	972	23	21	18	15	12
PA/HT360	21 (11.7)	20 (11.1)	19 (10.6)	16 (8.9)	156	80	75	70	65	60	1076	27	24	21	18	16
					161	83	78	73	68	63	1110	28	26	23	20	17
					171	86	81	76	71	66	1179	30	27	24	22	19
					179	89	84	79	74	69	1234	32	29	26	23	21
					185	91	86	81	76	71	1276	33	30	27	24	22
					193	94	89	84	79	74	1331	34	32	29	26	23
					199	96	91	86	81	76	1372	36	33	30	27	24
					205	98	93	88	83	78	1413	37	34	31	28	26
					214	101	96	91	86	81	1475	38	36	33	30	27
					223	104	99	94	89	84	1538	40	37	34	32	29
					230	106	101	96	91	86	1586	41	38	36	33	30
					236	108	103	98	93	88	1627	42	39	37	34	31
					246	111	106	101	96	91	1696	44	41	38	36	33
					253	113	108	103	98	93	1744	45	42	39	37	34
					263	116	111	106	101	96	1813	47	44	41	38	36
					271	118	113	108	103	98	1868	48	45	42	39	37
					282	121	116	111	106	101	1944	49	47	44	41	38
					289	123	118	113	108	103	1993	51	48	45	42	39
					299	125	120	115	110	105	2062	52	49	46	43	41
					309	128	123	118	113	108	2130	53	51	48	45	42
					317	130	125	120	115	110	2186	54	52	49	46	43
					325	132	127	122	117	112	2241	56	53	50	47	44
					337	135	130	125	120	115	2324	57	54	52	49	46
					346	137	132	127	122	117	2386	58	56	53	50	47
					354	139	134	129	124	119	2441	59	57	54	51	48
					368	142	137	132	127	122	2537	61	58	56	53	50

**Charging Procedure**  
**(For Two Stage Models, unit must be in High Stage)**

1. Measure Discharge line pressure by attaching a gauge to the service port.
2. Measure the Liquid line temperature by attaching a temperature sensing device to it.
3. Insulate the temperature sensing device so that the Outdoor Ambient doesn't affect the reading.
4. Refer to the required Subcooling in the table to find the required Subcooling based on the model size and the Outdoor Ambient temperature.
5. Interpolate if the Outdoor temperature lies in between the table values.
6. Find the Pressure Valve corresponding to the measured Pressure on the Compressor Discharge line.
7. Read across from the Pressure reading to obtain the Liquid line temperature for a required Subcooling.
8. Add Charge if the measured temperature is higher than the liquid line temperature value in the table.
9. Remove charge if the measured temperature is lower than the liquid line temperature in the table.
10. Add Charge using the service connection on the Suction line of the Compressor.

PHT324

ID Airflow (SCFM)	700					800					900					
	57/14	62/17	63/17††	67/19	72/22	57/14	62/17	63/17††	67/19	72/22	57/14	62/17	63/17††	67/19	72/22	
OD Ambient (° F/ ° C) db	Entering Indoor Temperature - Degrees F/ Degrees C, Wet Bulb															
75/24	MBh †	19.9	20.4	20.9	22.6	24.7	20.7	21.0	21.4	23.2	25.2	21.5	21.6	21.9	23.6	24.2
	S/T ‡	1.00	0.91	0.73	0.70	0.51	1.00	0.96	0.76	0.73	0.53	1.00	1.00	0.79	0.76	0.51
	AMPS*	6.5	6.5	6.5	6.5	6.6	6.6	6.6	6.6	6.6	6.7	6.7	6.7	6.7	6.7	6.9
	HI PR	171	172	173	175	178	173	173	174	176	179	174	174	174	176	180
	LO PR	73	75	77	82	89	77	77	79	85	91	79	79	80	86	87
85/29	MBh †	19.1	19.5	19.9	21.6	23.9	19.9	20.0	20.4	22.1	24.4	20.6	20.6	20.8	22.5	24.8
	S/T ‡	1.00	0.93	0.74	0.71	0.52	1.00	0.99	0.77	0.74	0.53	1.00	1.00	0.81	0.78	0.55
	AMPS*	7.2	7.2	7.3	7.4	7.4	7.3	7.3	7.4	7.4	7.5	7.5	7.5	7.5	7.5	7.6
	HI PR	198	199	200	204	206	200	200	201	204	207	202	202	202	205	208
	LO PR	75	76	78	84	91	78	79	80	86	93	81	81	81	88	95
95/35	MBh †	18.4	18.6	19.0	20.5	22.8	19.1	19.1	19.4	23.0	23.4	19.8	19.8	19.7	21.4	23.8
	S/T ‡	1.00	0.96	0.75	0.72	0.52	1.00	1.00	0.79	0.76	0.54	1.00	1.00	0.83	0.80	0.56
	AMPS*	8.1	8.1	8.1	8.2	8.3	8.2	8.2	8.2	8.3	8.4	8.3	8.3	8.3	8.4	8.5
	HI PR	228	229	229	233	237	230	230	231	235	238	232	232	232	236	239
	LO PR	77	78	79	85	93	80	80	81	87	95	83	83	82	89	97
105/41	MBh †	17.5	17.6	17.9	19.5	21.7	18.3	18.3	18.3	19.9	22.2	18.9	18.9	18.6	20.2	22.6
	S/T ‡	1.00	1.00	0.77	0.74	0.53	1.00	1.00	0.81	0.78	0.55	1.00	1.00	0.85	0.82	0.57
	AMPS*	9.0	9.0	9.0	9.1	9.2	9.1	9.1	9.1	9.2	9.3	9.2	9.2	9.2	9.3	9.4
	HI PR	260	261	261	266	271	263	263	263	267	272	265	265	264	268	273
	LO PR	79	79	80	86	94	82	82	82	88	97	85	85	83	90	98
115/46	MBh †	16.6	16.6	16.7	18.3	20.4	17.3	17.3	17.1	18.7	20.9	17.9	17.9	17.4	19.0	21.2
	S/T ‡	1.00	1.00	0.80	0.76	0.54	1.00	1.00	0.84	0.80	0.56	1.00	1.00	0.88	0.85	0.58
	AMPS*	10.0	10.0	10.0	10.1	10.3	10.1	10.1	10.1	10.2	10.4	10.2	10.2	10.2	10.3	10.5
	HI PR	296	296	296	301	307	298	298	297	302	309	300	300	298	304	310
	LO PR	81	81	81	88	96	84	84	83	89	98	87	87	85	91	100

Air Delivery in CFM - Dry Coil - No Filter (Add .05 Static Press for Wet Coil)

Speed Tap	External Static Pressure (Inch Water Col)									
	0.1	0.2	0.3	0.4	0.5	0.6	0.7	0.8	0.9	1.0
1	1078	833	783	720	681	615	489	435	378	317
2	1170	1102	1052	1006	964	921	881	838	789	684
3	-	-	-	-	-	-	-	-	-	-
4	-	-	-	-	-	-	-	-	-	-
5	-	-	-	-	-	-	-	-	-	-

- Notes: † Net Capacity (BTU/ HR/1000)  
‡ Sensible Heat Ratio (Sensible Capacity / Net Capacity)  
†† At 75°F entering dry bulb - Tennessee Valley Authority [TVA] rating conditions; all others at 80°F entering dry bulb.  
S/T are based on 80°F db entering air at the indoor coil. For sensible capacities at other than 80°F db, deduct 835 Btuh per 1000 cfm of indoor coil air from MBhS/T for each degree below 80°F, or add 835 Btuh per 1000 cfm of indoor air from MBhS/T for each degree above 80°F  
\* System amps is total unit amps

		PHT330														
		875					1000					1125				
OD Ambient (° F/° C) db	ID Airflow (SCFM)	Entering Indoor Temperature - Degrees F/ Degrees C, Wet Bulb														
		57/14	62/17	63/17††	67/19	72/22	57/14	62/17	63/17††	67/19	72/22	57/14	62/17	63/17††	67/19	72/22
75/24	MBh †	26.7	27.8	28.5	30.8	33.4	27.8	28.4	29.1	31.4	33.8	28.8	29.0	29.5	31.8	34.0
	S/T ‡	1.00	0.92	0.74	0.71	0.52	1.00	0.96	0.76	0.73	0.53	1.00	1.00	0.79	0.76	0.54
	AMPS*	8.8	8.9	8.9	8.9	9.0	9.0	9.0	9.0	9.0	9.1	9.1	9.1	9.1	9.2	9.3
	HI PR	181	183	183	186	190	183	184	184	187	191	184	184	185	187	191
	LO PR	69	72	73	78	84	72	74	75	80	85	75	75	76	81	86
85/29	MBh †	25.7	26.5	27.1	29.4	32.3	26.8	27.0	27.6	30.0	32.8	27.7	27.7	28.1	30.4	33.1
	S/T ‡	1.00	0.94	0.75	0.72	0.53	1.00	0.98	0.78	0.75	0.54	1.00	1.00	0.81	0.78	0.55
	AMPS*	9.7	9.7	9.8	9.8	9.9	9.9	9.9	9.9	10.0	10.1	10.0	10.0	10.0	10.1	10.2
	HI PR	209	210	211	215	219	211	212	213	215	220	213	213	213	216	220
	LO PR	71	73	75	80	87	74	75	76	82	88	77	77	77	83	89
95/35	MBh †	24.7	25.2	25.8	28.0	31.0	25.7	25.8	26.2	28.6	31.5	26.6	26.6	26.6	29.0	31.9
	S/T ‡	1.00	0.96	0.76	0.73	0.53	1.00	1.00	0.80	0.77	0.55	1.00	1.00	0.83	0.80	0.56
	AMPS*	10.7	10.8	10.8	10.9	11.0	10.9	10.9	10.9	11.0	11.1	11.1	11.1	11.1	11.1	11.2
	HI PR	240	241	242	246	250	242	242	243	247	251	244	244	244	247	252
	LO PR	73	74	76	82	89	76	76	77	83	90	79	79	79	84	91
105/41	MBh †	23.7	23.9	24.4	26.5	29.6	24.6	24.6	24.9	27.1	30.1	25.4	25.4	25.2	27.5	30.4
	S/T ‡	1.00	0.99	0.78	0.75	0.54	1.00	1.00	0.82	0.79	0.56	1.00	1.00	0.85	0.82	0.58
	AMPS*	11.9	11.9	11.9	12.1	12.1	12.1	12.1	12.1	12.2	12.3	12.3	12.3	12.2	12.3	12.4
	HI PR	273	274	275	280	284	276	276	276	281	285	278	278	277	282	286
	LO PR	75	76	77	83	90	78	78	79	85	92	81	81	80	86	93
115/46	MBh †	22.5	22.5	23.0	25.0	28.1	23.4	23.4	23.3	25.4	28.6	24.2	24.2	23.6	25.8	28.9
	S/T ‡	1.00	1.00	0.80	0.77	0.55	1.00	1.00	0.84	0.81	0.57	1.00	1.00	0.88	0.85	0.59
	AMPS*	13.1	13.1	13.1	13.3	13.4	13.3	13.3	13.3	13.5	13.6	13.5	13.5	13.4	13.6	13.7
	HI PR	309	309	310	316	322	312	312	312	318	323	315	315	313	319	324
	LO PR	77	77	78	84	92	80	80	80	86	93	83	83	81	87	94
Air Delivery in CFM - Dry Coil - No Filter (Add .05 Static Press for Wet Coil)																
Speed Tap		External Static Pressure (Inch Water Col)														
		0.1	0.2	0.3	0.4	0.5	0.6	0.7	0.8	0.9	1.0					
1		-	-	-	-	-	-	-	-	-	-					
2		1170	1102	1052	1006	964	921	881	838	789	684					
3		1266	1221	1184	1152	1121	1089	1047	1017	985	951					
4		-	-	-	-	-	-	-	-	-	-					
5		-	-	-	-	-	-	-	-	-	-					

Notes: † Net Capacity (BTU/ HR/1000)  
‡ Sensible Heat Ratio (Sensible Capacity / Net Capacity)  
†† At 75°F entering dry bulb - Tennessee Valley Authority (TVA) rating conditions; all others at 80°F entering dry bulb.  
S/T are based on 80°F db entering air at the indoor coil. For sensible capacities at other than 80°F db, deduct 835 Btuh per 1000 cfm of indoor coil air from MBhxS/T for each degree below 80°F, or add 835 Btuh per 1000 cfm of indoor air from MBhxS/T for each degree above 80°F  
\* System amps is total unit amps

50CT500422 - 2.0

		PHT336														
		1050					1200					1350				
OD Ambient (° F/ ° C) db	ID Airflow (SCFM)	Entering Indoor Temperature - Degrees F/ Degrees C, Wet Bulb														
		57/14	62/17	63/17††	67/19	72/22	57/14	62/17	63/17††	67/19	72/22	57/14	62/17	63/17††	67/19	72/22
75/24	MBh †	32.7	34.0	34.8	37.6	40.9	34.1	34.8	35.6	38.4	41.5	34.1	34.8	35.6	38.4	41.5
	S/T ‡	1.00	0.87	0.69	0.67	0.49	1.00	0.91	0.72	0.70	0.50	1.00	0.91	0.72	0.70	0.50
	AMPS*	11.0	11.1	11.2	11.2	11.3	11.3	11.3	11.3	11.4	11.5	11.3	11.3	11.3	11.4	11.5
	HI PR	182	184	185	187	192	184	185	185	188	193	184	185	185	188	193
	LO PR	71	74	76	81	88	75	76	77	83	89	75	76	77	83	89
85/29	MBh †	31.5	32.5	33.2	36.0	39.6	32.8	33.2	33.9	36.7	40.3	32.8	33.2	33.9	36.7	40.3
	S/T ‡	1.00	0.89	0.71	0.68	0.50	1.00	0.93	0.74	0.71	0.51	1.00	0.93	0.74	0.71	0.51
	AMPS*	12.2	12.2	12.3	12.4	12.5	12.4	12.4	12.5	12.6	12.7	12.4	12.4	12.5	12.6	12.7
	HI PR	210	212	213	216	221	212	213	214	217	222	212	213	214	217	222
	LO PR	73	75	77	83	90	77	77	79	85	92	77	77	79	85	92
95/35	MBh †	30.3	30.9	31.6	34.3	38.0	31.5	31.6	32.3	35.0	38.7	31.5	31.6	32.3	35.0	38.7
	S/T ‡	1.00	0.91	0.72	0.69	0.50	1.00	1.00	0.75	0.72	0.52	1.00	1.00	0.75	0.72	0.52
	AMPS*	13.4	13.4	13.5	13.7	13.8	13.6	13.6	13.7	13.8	14.0	13.6	13.6	13.7	13.8	14.0
	HI PR	241	242	243	248	253	243	244	244	249	254	243	244	244	249	254
	LO PR	75	77	78	84	92	78	79	80	86	94	78	79	80	86	94
105/41	MBh †	29.0	29.3	30.0	32.5	36.2	30.2	30.1	30.5	33.1	36.9	30.2	30.1	30.5	33.1	36.9
	S/T ‡	1.00	0.93	0.74	0.71	0.51	1.00	1.00	0.77	0.74	0.53	1.00	1.00	0.77	0.74	0.53
	AMPS*	14.7	14.7	14.8	15.0	15.2	15.0	15.0	15.0	15.2	15.4	15.0	15.0	15.0	15.2	15.4
	HI PR	274	275	276	282	287	277	277	278	283	288	277	277	278	283	288
	LO PR	77	78	79	86	93	80	80	81	87	95	80	80	81	87	95
115/46	MBh †	27.5	27.5	28.1	30.6	34.2	28.6	28.6	28.6	31.1	34.9	28.6	28.6	28.6	31.1	34.9
	S/T ‡	1.00	1.00	0.76	0.73	0.52	1.00	1.00	0.80	0.76	0.54	1.00	1.00	0.80	0.76	0.54
	AMPS*	16.1	16.1	16.2	16.4	16.7	16.4	16.4	16.4	16.7	16.9	16.4	16.4	16.4	16.7	16.9
	HI PR	310	310	311	318	325	313	313	313	319	326	313	313	313	319	326
	LO PR	80	80	81	87	95	83	83	82	89	97	83	83	82	89	97

Air Delivery in CFM - Dry Coil - No Filter (Add .05 Static Press for Wet Coil)

Speed Tap	External Static Pressure (Inch Water Col)									
	0.1	0.2	0.3	0.4	0.5	0.6	0.7	0.8	0.9	1.0
1	1420	1288	1209	1170	1153	1106	1065	1011	967	910
2	1497	1438	1387	1334	1294	1292	1247	1208	1171	1117
3	-	-	-	-	-	-	-	-	-	-
4	-	-	-	-	-	-	-	-	-	-
5	-	-	-	-	-	-	-	-	-	-

Notes: † Net Capacity (BTU/ HR/1000)  
‡ Sensible Heat Ratio (Sensible Capacity / Net Capacity)  
†† At 75°F entering dry bulb - Tennessee Valley Authority (TVA) rating conditions; all others at 80°F entering dry bulb.  
S/T are based on 80°F db entering air at the indoor coil. For sensible capacities at other than 80°F db, deduct 835 Btuh per 1000 cfm of indoor coil air from MBhxS/T for each degree below 80°F, or add 835 Btuh per 1000 cfm of indoor air from MBhxS/T for each degree above 80°F  
\* System amps is total unit amps

		PHT342														
		1225					1400					1575				
OD Ambient (° F / ° C) db	ID Airflow (SCFM)	Entering Indoor Temperature - Degrees F/ Degrees C, Wet Bulb														
		57/14	62/17	63/17 <sup>††</sup>	67/19	72/22	57/14	62/17	63/17 <sup>††</sup>	67/19	72/22	57/14	62/17	63/17 <sup>††</sup>	67/19	72/22
75/24	MBh†	37.9	38.8	40.2	40.9	43.7	37.7	40.3	39.6	43.6	43.9	37.6	40.1	40.2	42.5	44.7
	S/T ‡	1.00	0.99	0.72	0.71	0.51	1.22	0.99	0.76	0.73	0.53	1.22	0.95	0.78	0.77	0.55
	AMPS*	13.2	14.2	14.2	14.1	15.6	13.5	14.4	14.4	14.4	14.4	14.8	14.7	15.0	14.9	14.8
	HI PR	171	171	172	175	178	172	172	173	176	178	173	173	174	177	178
	LO PR	69	71	73	77	80	73	73	74	78	79	75	75	75	78	79
85/29	MBh†	36.1	36.7	38.5	40.1	42.7	37.2	38.6	39.0	40.6	43.6	37.4	39.8	39.6	42.2	44.6
	S/T ‡	1.00	0.99	0.73	0.71	0.52	1.00	0.99	0.77	0.76	0.55	1.00	0.99	0.81	0.79	0.57
	AMPS*	14.6	14.6	14.9	15.0	15.5	14.9	15.1	15.1	15.8	15.0	15.4	15.4	15.4	15.5	15.6
	HI PR	198	199	199	201	205	199	200	200	202	206	200	200	200	203	207
	LO PR	71	72	74	80	85	75	75	76	82	86	78	78	78	83	87
95/35	MBh†	35.1	35.9	36.7	39.3	42.2	36.6	37.2	37.4	40.0	42.4	37.0	38.1	36.5	40.5	42.8
	S/T ‡	1.00	1.00	0.75	0.72	0.53	1.00	1.00	0.79	0.76	0.55	1.00	0.99	0.84	0.81	0.58
	AMPS*	16.1	15.9	16.0	16.1	16.2	16.4	16.3	16.3	16.4	16.5	16.7	16.6	16.6	16.8	16.9
	HI PR	227	227	228	231	234	229	229	229	231	235	230	230	230	232	236
	LO PR	73	73	75	81	89	76	76	77	83	90	79	80	78	85	91
105/41	MBh†	32.8	33.9	34.3	36.8	39.3	34.8	35.2	34.9	37.4	39.7	33.9	34.1	33.4	36.0	39.9
	S/T ‡	1.00	0.99	0.77	0.74	0.54	1.00	1.00	0.81	0.79	0.56	1.00	0.99	0.86	0.84	0.57
	AMPS*	17.8	17.2	17.2	17.4	17.6	17.4	17.6	17.6	17.7	17.9	17.9	17.8	17.8	18.0	18.3
	HI PR	259	259	259	263	266	261	261	260	264	267	263	263	261	264	267
	LO PR	75	75	76	82	91	78	78	78	84	93	81	81	79	86	94
115/46	MBh†	31.3	32.2	32.3	34.8	36.0	31.3	31.7	31.3	33.7	37.6	32.1	32.7	30.5	32.7	36.6
	S/T ‡	1.00	1.00	0.79	0.76	0.53	1.00	0.99	0.85	0.82	0.58	1.00	0.99	1.01	1.01	0.61
	AMPS*	19.6	18.7	18.7	19.0	18.8	19.9	20.5	19.0	19.2	19.5	21.0	20.7	20.7	21.0	21.3
	HI PR	293	293	293	297	301	295	295	294	299	302	297	297	295	300	302
	LO PR	77	77	77	83	92	80	80	78	85	94	83	83	80	86	95

Air Delivery in CFM • Dry Coil • No Filter (Add .05 Static Press for Wet Coil)

Speed Tap	External Static Pressure (Inch Water Col)									
	0.1	0.2	0.3	0.4	0.5	0.6	0.7	0.8	0.9	1.0
1	•	•	•	•	•	•	•	•	•	•
2	•	•	•	•	•	•	•	•	•	•
3	1559	1520	1480	1438	1401	1359	1318	1268	1218	1181
4	1694	1657	1620	1583	1550	1514	1474	1437	1389	•
5	•	•	•	•	•	•	•	•	•	•

Notes: When the reported data fall between the published data, interpolation may be performed. Extrapolation is not an acceptable practice.

† Total capacities are net capacities. Blower heat has been subtracted.

‡ Sensible Heat Ratio (Sensible Capacity / Net Capacity)

†† At AAVating indoor condition (75°F db/ 63°F wb), All other indoor air temperatures are at 80°F db

\* System amps is total unit amps

S/T ‡ based on 80°F db entering air at the indoor coil. For sensible capacities at other than 80°F db, deduct 835 Btuh per 1000 cfm of indoor coil airflow for each degree below 80°F or add 835 Btuh per 1000 cfm of indoor coil air for each degree above 80°F

50CT500424 - 2.0

		PHT348														
		1400					1600					1800				
OD Ambient (° F/ ° C) db	ID Airflow (SCFM)	Entering Indoor Temperature - Degrees F/ Degrees C, Wet Bulb														
		57/14	62/17	63/17††	67/19	72/22	57/14	62/17	63/17††	67/19	72/22	57/14	62/17	63/17††	67/19	72/22
75/24	MBh †	43.90	45.10	46.00	49.52	54.55	45.87	46.26	47.01	50.59	55.71	47.54	47.54	47.79	51.42	56.60
	S/T ‡	1.00	0.96	0.77	0.74	0.55	1.00	1.01	0.80	0.77	0.56	1.00	1.00	0.84	0.81	0.58
	Amps*	13.26	13.31	13.35	13.52	13.74	13.57	13.59	13.62	13.79	14.01	13.87	13.86	13.87	14.04	14.27
	HI PR	204	206	207	211	217	207	207	208	212	218	209	209	209	214	220
	LO PR	74	76	77	83	92	78	78	79	86	94	81	81	81	87	96
85/29	MBh †	42.26	43.11	43.94	47.34	52.19	44.13	44.23	44.87	48.32	53.26	45.70	45.70	45.59	49.08	54.07
	S/T ‡	1.00	0.96	0.77	0.74	0.54	1.00	0.99	0.81	0.78	0.56	1.00	1.00	0.84	0.81	0.58
	Amps*	15.29	15.33	15.37	15.57	15.83	15.62	15.63	15.65	15.85	16.11	15.93	15.93	15.92	16.12	16.38
	HI PR	236	237	238	243	250	239	239	240	245	251	242	242	241	246	253
	LO PR	75	77	78	84	93	79	79	80	87	95	82	82	82	88	97
95/35	MBh †	40.57	41.07	41.83	45.11	49.78	42.33	42.32	42.68	46.00	50.75	43.81	43.81	43.33	46.69	51.48
	S/T ‡	1.00	0.97	0.77	0.74	0.54	1.00	1.00	0.81	0.78	0.56	1.00	1.00	0.85	0.82	0.59
	Amps*	17.59	17.62	17.66	17.89	18.18	17.94	17.94	17.96	18.18	18.47	18.28	18.28	18.24	18.46	18.76
	HI PR	271	272	273	278	285	274	274	275	280	287	277	277	276	281	288
	LO PR	77	78	79	86	94	81	81	81	88	96	84	84	83	89	98
105/41	MBh †	38.82	39.01	39.67	42.81	47.31	40.47	40.47	40.43	43.62	48.18	41.86	41.86	41.03	44.25	48.84
	S/T ‡	1.00	0.98	0.78	0.75	0.54	1.00	1.00	0.82	0.79	0.57	1.00	1.00	0.86	0.83	0.59
	Amps*	20.17	20.19	20.23	20.49	20.82	20.56	20.56	20.54	20.80	21.13	20.91	20.91	20.83	21.09	21.42
	HI PR	310	310	311	317	324	313	313	313	318	326	316	316	314	320	327
	LO PR	79	79	80	87	95	83	83	82	89	97	86	86	84	90	99
115/46	MBh †	37.02	37.02	37.45	40.47	44.78	38.57	38.57	38.14	41.19	45.56	39.86	39.86	38.67	41.75	46.14
	S/T ‡	1.00	1.00	0.79	0.76	0.55	1.00	1.00	0.83	0.80	0.57	1.00	1.00	0.87	0.84	0.59
	Amps*	23.06	23.06	23.09	23.38	23.76	23.47	23.47	23.41	23.71	24.08	23.85	23.85	23.72	24.02	24.39
	HI PR	351	351	352	358	366	355	355	354	360	368	358	358	355	362	369
	LO PR	81	81	82	88	96	85	85	83	90	98	88	88	85	91	100

Air Delivery in CFM - Dry Coil - No Filter (Add .05 Static Press for Wet Coil)

Speed Tap	External Static Pressure (Inch Water Col)									
	0.1	0.2	0.3	0.4	0.5	0.6	0.7	0.8	0.9	1.0
1	1213	1028	909	825	762	667	613	-	-	-
2	1299	1226	1157	1094	1037	961	915	841	769	719
3	1698	1652	1601	1542	1494	1442	1390	1324	1265	1201
4	1974	1924	1859	1813	1781	1706	1651	1602	1538	1485
5	-	-	-	-	-	-	-	-	-	-

Notes: † Net Capacity (BTU/ HR/1000)

‡ Sensible Heat Ratio (Sensible Capacity / Net Capacity)

†† At 75°F entering dry bulb - Tennessee Valley Authority [TVA] rating conditions; all others at 80°F entering dry bulb.

S/T are based on 80°F db entering air at the indoor coil. For sensible capacities at other than 80°F db, deduct 835 Btuh per 1000 cfm of indoor coil air from MBhxS/T for each degree below 80°F, or add 835 Btuh per 1000 cfm of indoor air from MBhxS/T for each degree above 80°F

\* System amps is total unit amps

50CT500402 - 2.0

ID Airflow (SCFM)		PHT360														
		1750					1875					2000				
		Entering Indoor Temperature - Degrees F/ Degrees C, Wet Bulb														
OD Ambient (° F/ ° C) db		57/14	62/17	63/17 <sup>††</sup>	67/19	72/22	57/14	62/17	63/17 <sup>††</sup>	67/19	72/22	57/14	62/17	63/17 <sup>††</sup>	67/19	72/22
		75/24	MBh <sup>†</sup>	51.5	52.1	52.8	56.7	62.0	52.7	52.8	53.4	57.2	62.6	55.5	55.5	54.8
S/T <sup>‡</sup>	0.95		0.92	0.73	0.71	0.51	0.95	0.94	0.75	0.73	0.52	0.95	0.95	0.80	0.78	0.55
AMPS*	18.7		18.7	18.8	19.2	19.8	19.1	19.1	19.2	19.6	20.1	19.8	19.8	19.7	20.1	20.6
HI PR	193		193	194	198	203	194	194	194	198	204	197	197	196	200	206
LO PR	74		75	76	82	91	76	76	77	83	92	81	81	79	86	94
85/29	MBh <sup>†</sup>	49.7	49.9	50.5	54.1	59.2	50.7	50.8	51.0	54.6	59.7	53.3	53.4	52.2	55.9	60.9
	S/T <sup>‡</sup>	0.95	0.94	0.74	0.72	0.52	0.95	0.95	0.76	0.74	0.53	0.95	0.95	0.82	0.80	0.56
	AMPS*	20.5	20.6	20.6	21.0	21.5	20.9	20.9	20.9	21.3	21.9	21.6	21.6	21.4	21.8	22.4
	HI PR	220	220	221	225	230	221	221	221	225	231	224	224	223	227	232
	LO PR	76	76	77	83	92	78	78	78	84	93	83	83	80	87	95
95/35	MBh <sup>†</sup>	47.8	47.8	48.1	51.5	56.3	48.7	48.8	48.6	52.0	56.8	51.2	51.2	49.7	53.1	57.9
	S/T <sup>‡</sup>	0.95	0.95	0.76	0.74	0.53	0.95	0.95	0.78	0.76	0.54	0.95	0.95	0.84	0.83	0.58
	AMPS*	22.6	22.6	22.6	23.0	23.5	23.0	23.0	23.0	23.3	23.8	23.6	23.6	23.4	23.8	24.3
	HI PR	250	250	250	254	260	251	251	251	255	260	254	254	252	256	262
	LO PR	78	78	78	85	93	79	80	79	86	94	84	84	81	88	96
105/41	MBh <sup>†</sup>	45.8	45.9	45.8	49.0	53.5	46.7	46.8	46.2	49.4	53.9	48.9	49.0	47.2	50.4	54.8
	S/T <sup>‡</sup>	0.95	0.95	0.78	0.76	0.54	0.95	0.95	0.80	0.78	0.55	0.95	0.95	0.87	0.85	0.59
	AMPS*	24.9	24.9	24.8	25.2	25.6	25.2	25.2	25.2	25.5	26.0	25.8	25.8	25.6	26.0	26.4
	HI PR	283	283	282	286	292	284	284	283	287	293	287	287	284	289	294
	LO PR	79	80	79	86	94	81	81	80	87	95	86	86	82	89	97
115/46	MBh <sup>†</sup>	43.8	43.8	43.4	46.3	50.4	44.6	44.7	43.7	46.7	50.6	46.6	46.7	44.7	47.6	51.4
	S/T <sup>‡</sup>	0.95	0.95	0.80	0.78	0.55	0.95	0.95	0.82	0.80	0.56	0.95	0.95	0.89	0.88	0.61
	AMPS*	27.3	27.3	27.3	27.6	28.0	27.7	27.7	27.6	27.9	28.3	28.3	28.3	28.1	28.4	28.8
	HI PR	318	318	317	321	327	319	319	318	322	327	322	322	319	324	328
	LO PR	81	82	80	87	96	83	83	81	88	97	88	88	83	90	99

Air Delivery in CFM • Dry Coil • No Filter (Add .05 Static Press for Wet Coil)

Speed Tap	External Static Pressure (Inch Water Col)									
	0.1	0.2	0.3	0.4	0.5	0.6	0.7	0.8	0.9	1.0
1	1389	1292	1228	1159	1104	1043	988	940	873	828
2	1461	1417	1364	1296	1243	1180	1129	1083	1026	978
3	2050	2008	1965	1923	1874	1828	1783	1734	1680	1622
4	2179	2132	2093	2049	2011	1968	1921	1877	1830	1760
5	.	.	.	.	.	.	.	.	.	.

Notes: † Net Capacity (BTU/ HR/1000)

‡ Sensible Heat Ratio (Sensible Capacity / Net Capacity)

†† At 75°F entering dry bulb - Tennessee Valley Authority [TVA] rating conditions; all others at 80°F entering dry bulb.

S/T are based on 80°F db entering air at the indoor coil. For sensible capacities at other than 80°F db, deduct 835 Btuh per 1000 cfm of indoor coil air from MBhxS/T for each degree below 80°F, or add 835 Btuh per 1000 cfm of indoor air from MBhxS/T for each degree above 80°F

\* System amps is total unit amps

50CT500426 - 2.0

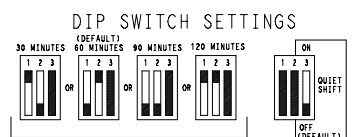
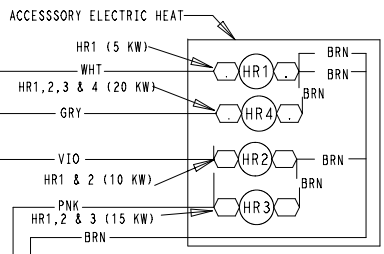
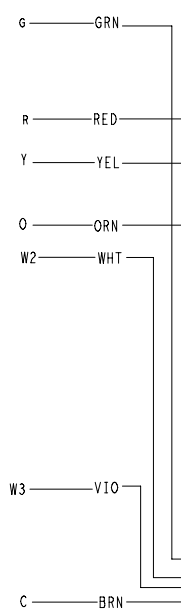
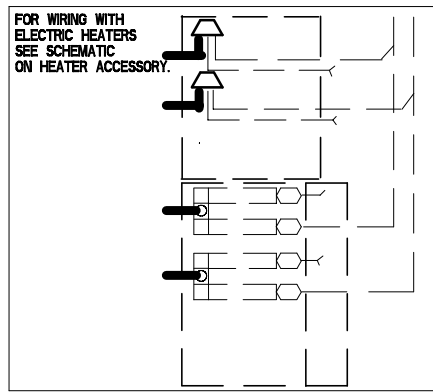
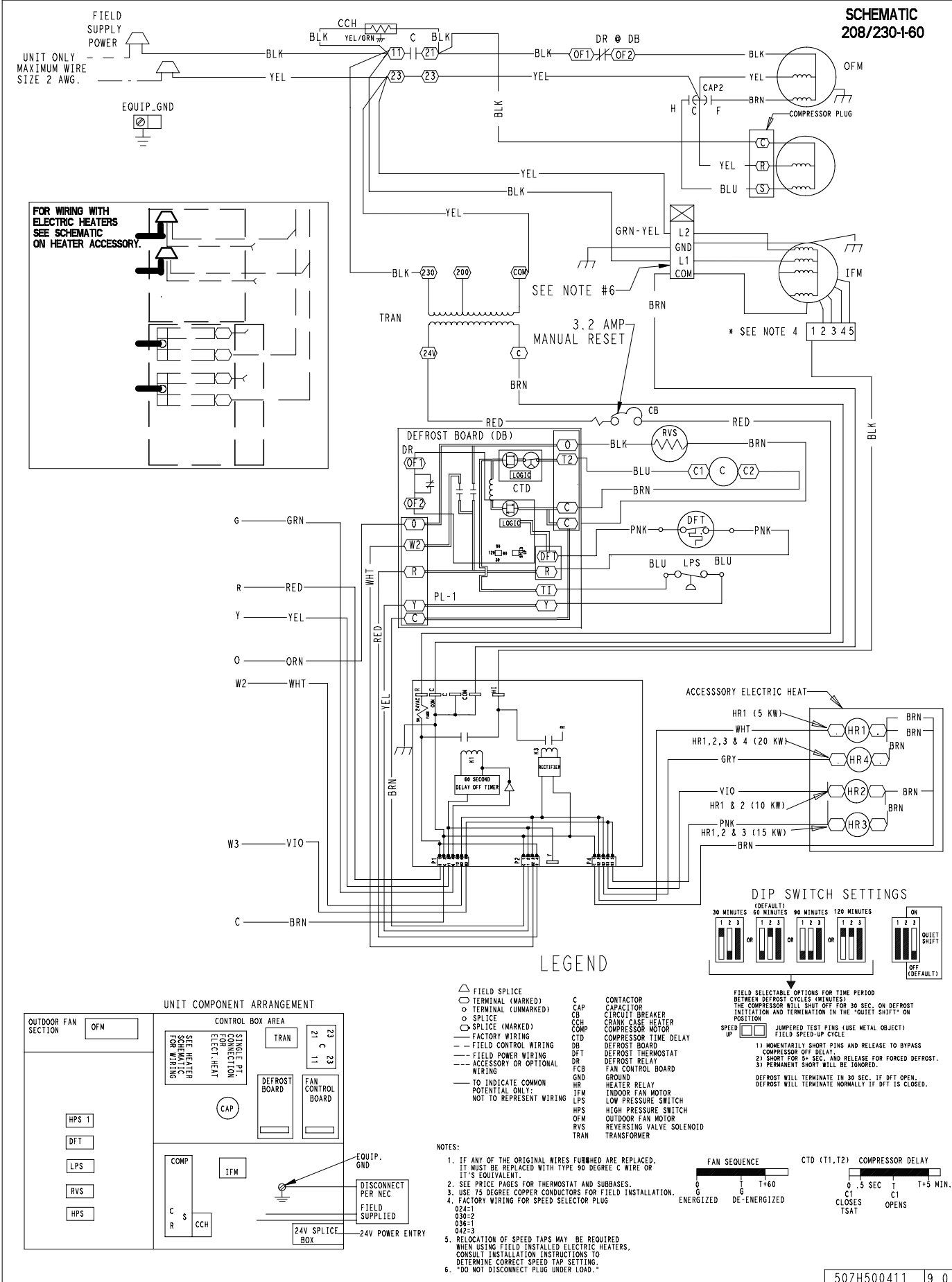

**LEGEND**

- △ FIELD SPLICE
  - TERMINAL (MARKED)
  - TERMINAL (UNMARKED)
  - SPLICE (MARKED)
  - SPLICE (UNMARKED)
  - FACTORY WIRING
  - - - FIELD CONTROL WIRING
  - - - FIELD POWER WIRING
  - - - ACCESSORY OR OPTIONAL WIRING
  - TO INDICATE COMMON POTENTIAL ONLY; NOT TO REPRESENT WIRING
- C CAPACITOR
  - CB CIRCUIT BREAKER
  - CCH CRANK CASE HEATER
  - COMP COMPRESSOR MOTOR
  - CTD COMPRESSOR TIME DELAY
  - DB DEFROST BOARD
  - DFT DEFROST THERMOSTAT
  - DR DEFROST RELAY
  - FCB FAN CONTROL BOARD
  - GND GROUND
  - HR HEATER RELAY
  - IFM INDOOR FAN MOTOR
  - LPS LOW PRESSURE SWITCH
  - HPS HIGH PRESSURE SWITCH
  - OFM OUTDOOR FAN MOTOR
  - RVS REVERSING VALVE SOLENOID
  - TRAN TRANSFORMER

- NOTES:**
1. IF ANY OF THE ORIGINAL WIRES FURNISHED ARE REPLACED, IT MUST BE REPLACED WITH TYPE 90 DEGREE C WIRE OR IT'S EQUIVALENT.
  2. SEE PRICE PAGES FOR THERMOSTAT AND SUBBASES.
  3. USE 75 DEGREE COPPER CONDUCTORS FOR FIELD INSTALLATION.
  4. FACTORY WIRING FOR SPEED SELECTOR PLUG
    - 024-1
    - 030-2
    - 038-1
    - 042-3
  5. RELOCATION OF SPEED TAPS MAY BE REQUIRED WHEN USING FIELD INSTALLED ELECTRIC HEATERS. CONSULT INSTALLATION INSTRUCTIONS TO DETERMINE CORRECT SPEED TAP SETTING.
  6. "DO NOT DISCONNECT PLUG UNDER LOAD."

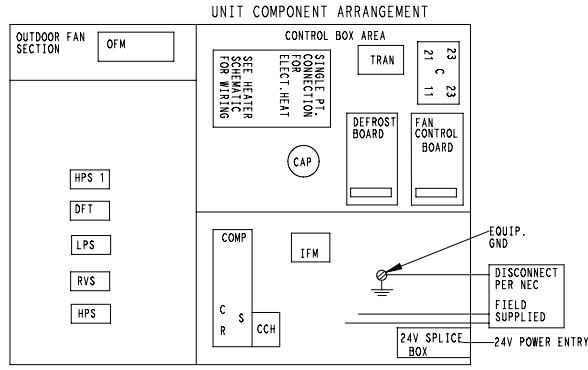
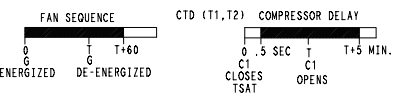



**SCHEMATIC  
208/230-1-60**

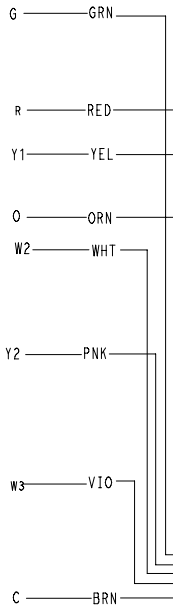
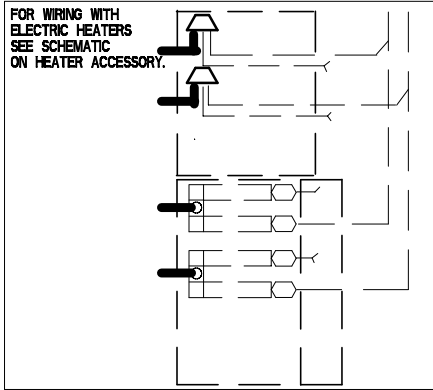
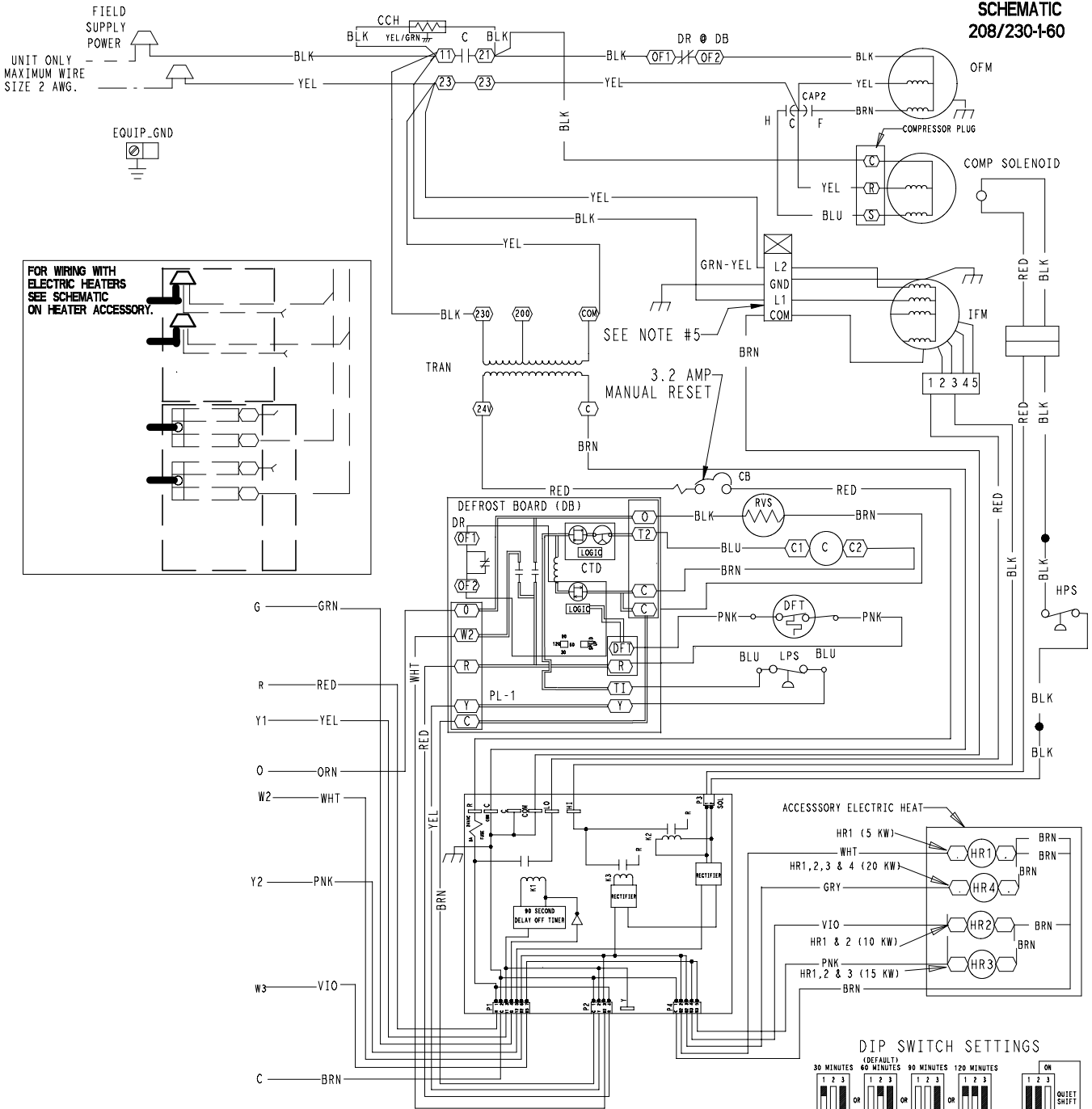

**LEGEND**

- △ FIELD SPLICE
  - TERMINAL (MARKED)
  - TERMINAL (UNMARKED)
  - SPLICE (UNMARKED)
  - SPLICE (MARKED)
  - FACTORY WIRING
  - - - FIELD CONTROL WIRING
  - - - FIELD POWER WIRING
  - - - ACCESSORY OR OPTIONAL WIRING
  - TO INDICATE COMMON POTENTIAL ONLY; NOT TO REPRESENT WIRING
- Legend symbols and abbreviations:
- C - CAPACITOR
  - CB - CIRCUIT BREAKER
  - CCH - CRANK CASE HEATER
  - COMP - COMPRESSOR MOTOR
  - CTD - COMPRESSOR TIME DELAY
  - DB - DEFROST BOARD
  - DFT - DEFROST THERMOSTAT
  - DR - DEFROST RELAY
  - FCB - FAN CONTROL BOARD
  - GND - GROUND
  - HR - HEATER RELAY
  - IFM - INDOOR FAN MOTOR
  - LPS - LOW PRESSURE SWITCH
  - HPS - HIGH PRESSURE SWITCH
  - OFM - OUTDOOR FAN MOTOR
  - RVS - REVERSING VALVE SOLENOID
  - TRAN - TRANSFORMER
- DIP SWITCH SETTINGS**
- FIELD SELECTABLE OPTIONS FOR TIME PERIOD BETWEEN DEFROST CYCLES (MINUTES):
- 60 MINUTES (DEFAULT)
  - 90 MINUTES
  - 120 MINUTES
- COMPRESSOR OFF DELAY:
- 1) MOMENTARILY SHORT PINS AND RELEASE TO BYPASS COMPRESSOR OFF DELAY.
  - 2) SHORT FOR 3+ SEC. AND RELEASE FOR FORCED DEFROST.
  - 3) PERMANENT SHORT WILL BE IGNORED.
- DEFROST WILL TERMINATE IN 30 SEC. IF DFT OPEN. DEFROST WILL TERMINATE NORMALLY IF DFT IS CLOSED.

**UNIT COMPONENT ARRANGEMENT**

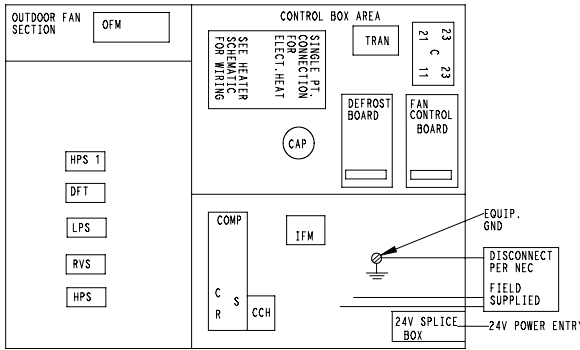

- NOTES:**
- IF ANY OF THE ORIGINAL WIRES FURNISHED ARE REPLACED, IT MUST BE REPLACED WITH TYPE 90 DEGREE C WIRE OR IT'S EQUIVALENT.
  - SEE PRICE PAGES FOR THERMOSTAT AND SUBBASES.
  - USE 75 DEGREE COPPER CONDUCTORS FOR FIELD INSTALLATION.
  - RELOCATION OF SPEED TAPS MAY BE REQUIRED WHEN USING FIELD INSTALLED ELECTRIC HEATERS. CONSULT INSTALLATION INSTRUCTIONS TO DETERMINE CORRECT SPEED TAP SETTING.
  - DO NOT DISCONNECT PLUG UNDER LOAD.

