

PH55 / PYPA SERIES HEAT PUMP - Single Phase

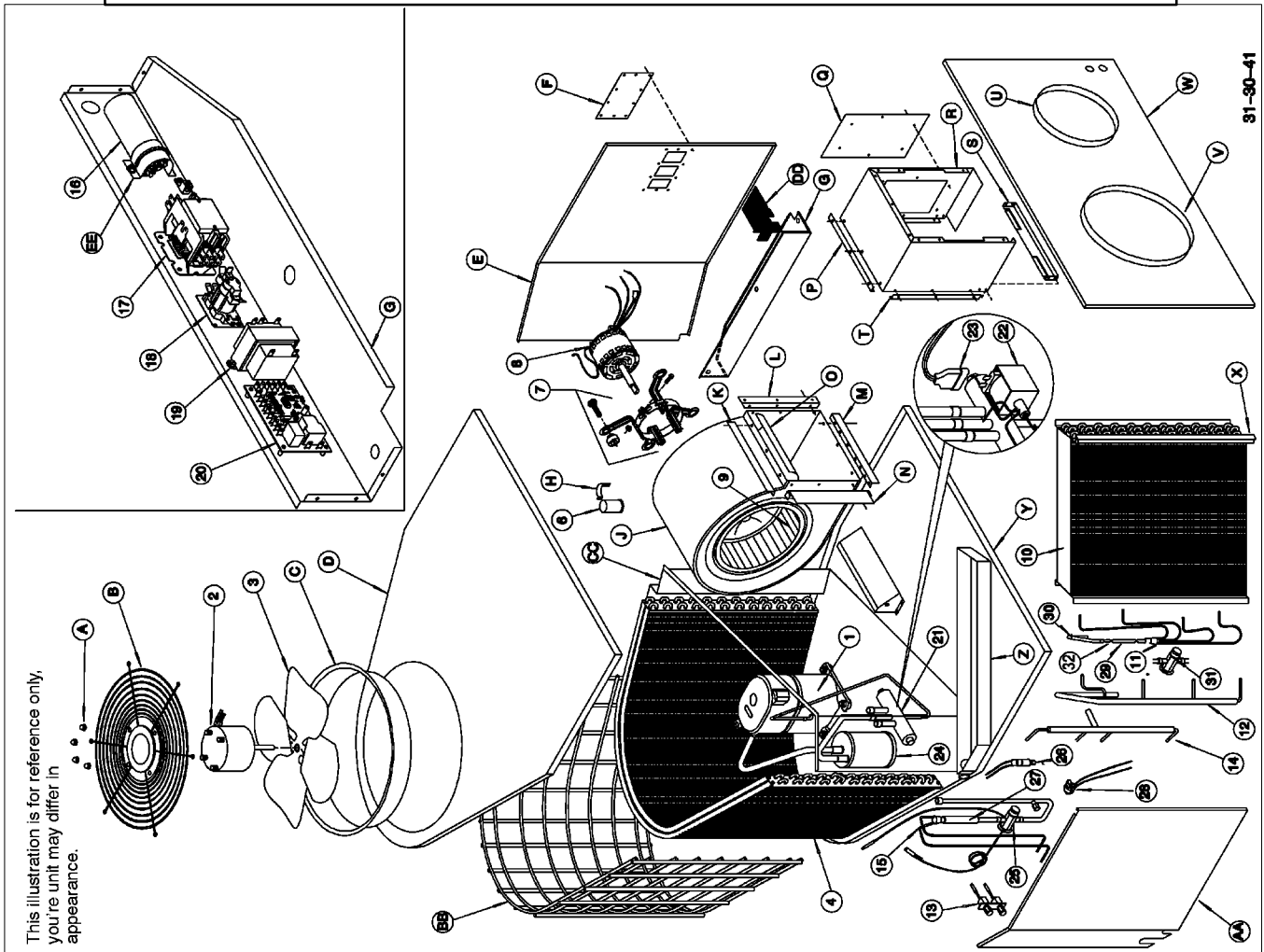

PH5524AKA3, PH5530AKA3, PH5536AKA2, PH5542AKA2, PH5548AKA2, PH5560AKA2
 PYPA24GA3, PYPA30GA3, PYPA30GA2, PYPA42GA2, PYPA48GA2, PYPA60GA2

	DESCRIPTION	PART No.	2	3	3	4	4	6		DESCRIPTION	PART No.	2	3	3	4	4	6
			4	0	6	2	8	0				4	0	6	2	8	0
1	Compr., CR24KFPFV	1083695	1							8	Motor, Blower	1081398	-	1			
1	CR28KFPFV	1082717	-	1						8		1081399	-	-	1	1	
1	CR34K6PFV	1083696	-	-	1					8		1081194	-	-	-	-	1
1	ZR42KCPFV	1082502	-	-	-	1				8		1082177	-	-	-	-	1
1	ZR45KCPFV	1082503	-	-	-	-	1			9	Wheel, Blower	2120144	1	1			
1	ZR57K3PFV	1083019	-	-	-	-	-	1		9		706038	-	-	1	1	
2	Motor, Condenser	1082491	1	1						9		1082068	-	-	-	-	1
2		1082492	-	-	1	1	1			9		1082069	-	-	-	-	1
2		1082070	-	-	-	-	-	1		10	Evaporator Coil	1081287	1				
3	Fan Blade, Condenser	1080794	1	1						10		1081288	-	1			
3		1080790	-	-	1	1	1	1		10		1081289	-	-	1		
4	Condenser Coil Assy	1081262	1							10		1081290	-	-	-	1	
4		1081263	-	1	1					10		1081291	-	-	-	-	1
4		1081264	-	-	-	1	1			10		1082336	-	-	-	-	1
4		1082372	-	-	-	-	-	1		11	Distributor, Evap 4 Hole	1065884	1	1	1	1	
6	Capacitor, 5 / 370V	1094954	1	1	1	1				11	6 Hole	1063218	-	-	-	-	1
6	20 / 370V	1094961	-	-	-	-	1	1		12	Manifold (Evap)	1081156	1	1	1		
7	Mount, Blow Motor Kit	609227	1	1	1	1	1			12		1081336	-	-	-	1	
7		5220200	-	-	-	-	-	1		12		1081157	-	-	-	-	1
7		24	-	-	-	-	-	-		12		1082710	-	-	-	-	1
8	Motor, Blower	1082061	1														

	DESCRIPTION	PART No.	2 4	3 0	3 6	4 2	4 8	6 0		DESCRIPTION	PART No.	2 4	3 0	3 6	4 2	4 8	6 0
13	Port Asy, Test	1083656	1	1	1	1	1	1	A	Nut, Cap	1067902	4	4	4	4	4	4
14	Manifold (Cond)	1081276	1						AA	Panel, Side (Evap)	1081102	1	1	1	1	1	1
14		1081277	-	1	1				B	Grille, Top	1064541	1	1	1	1	1	
14		1081278	-	-	-	1	1		B		1072868	-	-	-	-	-	1
14		1082373	-	-	-	-	-	1	BB	Grille, Inlet	1081378	1	1	1	1	1	1
15	Distributor Asy (Cond)	1081274	1						C	Orifice, Condenser Fan	1065724	1	1	1	1	1	1
15		1081280	-	1	1				CC	Panel, Center	1097343	1	1	1	1	1	1
15		1081281	-	-	-	1	1		D	Panel, Top	1068344	1	1	1	1	1	1
15		1083417	-	-	-	-	-	1	DD	Partition, Low Voltage	1082051	1	1	1	1	1	1
16	Capacitor, 35 + 3 / 440V	1082636	1	1					E	Panel, Side (Blower)	1081103	1	1	1	1	1	1
16	50 + 5 / 370V	1094993	-	-	1				EE	Clamp, Capacitor	1064218	1	1	1	1		1
16	40 + 5 / 440V	1094987	-	-	-	1			EE		1095021	-	-	-	-	1	
16	40 + 5 / 370V	1094980	-	-	-	-	1		F	Cover, Side (Blower)	1081375	1	1	1	1	1	1
16	80 +7.5 / 370V	1149999	-	-	-	-	-	1	G	Box, Control	1081220	1	1	1	1	1	1
17	Contactor, 25 Amp	1050699	1	1	1				H	Clamp, Capacitor	1095020	1	1	1	1		
17	35 Amp	1050839	-	-	-	1			H		1095022	-	-	-	-	1	1
17	40 Amp	1059574	-	-	-	-	1	1	J	Housing, Blower	1081214	1	1				
18	Sequencer	1054372	1	1	1	1	1	1	J		1081213	-	-	1	1	1	
19	Transformer	1056899	1	1	1	1	1	1	J		1082149	-	-	-	-	-	1
20	Control, Defrost	1069364	1	1	1	1	1	1	K	Bracket, Blow Mounting	1081116	1	1	1	1	1	
21	Valve, Reversing W/Coil	1095322	1						L	Bracket, Blow Mounting	1081395	1	1				
21		1095320	-	1	1				L	Bracket, Blow Mounting	1081119	-	-	1	1	1	
21		1095226	-	-	-	1			M	Bracket, Blow Mounting	1081117	1	1	1	1	1	
21		1095319	-	-	-	-	1	1	N	Bracket, Blow Mounting	1081396	1	1				
22	Coil, Rev. Valve (24V)	34329055	1	1	1	1	1	1	N	Bracket, Blow Mounting	1081118	-	-	1	1	1	
23	Harness, Rev. Valve	1066711	1	1	1	1	1	1	O	Panel, Blower Cutoff	7210200	1	1				
24	Accumulator	1053427	1	1	1				O		7210200	-	-	1	1	1	
24		1053428	-	-	-	1	1	1	O		13	-	-	1	1	1	
25	Valve, Expansion	1082030	1						O		1082176	-	-	-	-	-	1
25		1082031	-	1					P	Bracket, Heater Box	1081114	1	1	1	1	1	1
25		1082032	-	-	1				Q	Plate, Heater Cover	1083655	1	1	1	1	1	1
25		1082033	-	-	-	1			R	Box, Heater	1081111	1	1	1	1	1	1
25		1082034	-	-	-	-	1		S	Bracket, Heater Box	1081112	1	1	1	1	1	1
25		1083407	-	-	-	-	-	1	T	Bracket, Heater Box	1081113	1	1	1	1	1	
26	Switch, Low Pressure	1082129	-	-	-	1	1	1	T		1082179	-	-	-	-	-	1
27	Tube W/Strainer	1068116	1	1	1	1	1	1	U	Ring, Air Duct 12"	1066734	1	1	1	1	1	1
28	Sensor, Defrost	1082065	1	1	1	1	1	1	V	Ring, Air Duct 14"	1066735	1	1	1	1	1	1
29	Restrict, Flow Cont .058	1082043	1						W	Panel, Rear	1081101	1	1	1	1	1	1
29	.066	1082044	-	1					X	Bracket, Evap Coil	1081110	1	1	1	1	1	1
29	.069	1082045	-	-	1				Y	Panel, Base	1081100	1	1	1	1	1	1
29	.076	1082046	-	-	-	1			Z	Pan, Drain	1081120	1	1	1	1	1	1
29	.081	1082047	-	-	-	-	1			Manual, Parts List	4270410	1	1	1	1	1	1
30	Tube W/Strainer (Evap)	1083529	-	-	-	-	-	1			0300						
31	Valve, Expansion (Evap)	1082295	-	-	-	-	-	1		Manual, Owners	1067618	1	1	1	1	1	1
32	Tube W/Strainer / TXV	1068116	-	-	-	-	-	1		Manual, Installation	4270110	1	1	1	1	1	1
33	Plug, Compr. Harness	1083654	1	1	1	1	1	1			0100						

PH5524AKA / PYPA24GA

Style No:	2 Ton Pkg Heat Pump		Outdoor Ambient Temperature - Degrees F. Dry Bulb																Part No:												
			75				85				95				105					115											
			Entering Indoor Temperature - Degrees F. Wet Bulb																												
Voltage	208 / 230																														
Phase/Cycles	1																														
Ampacity	17																														
Wire Ga/Length	NEC																														
Delay Fuse	20																														
Max. Fuse/HACR	25																														
Compressor	COPELAND																														
RLA	11.3																														
LRA	61																														
Cap MFD/V	35 / 370																														
CC Heater	N/A																														
Start Kit	NAMA001SC																														
Cond & Evap	Cond	Evap																													
Type	Fan	Blower																													
Size	20	DD10-6																													
Motor-HP	1/6	1 / 4																													
Type	PSC	PSC																													
FLA	1	2.1																													
LRA	1.72	3.1																													
RPM	1100	1075																													
Cap MFD/V	3 / 440	5 / 370																													
PTCR	N/A																														
Hi Press	N/A																														
Low Press	N/A																														
Low Amb	N/A																														
LOC Press	N/A																														
Defrost	Timed																														
Sensor	31 / 51																														
Operating Chg	(R-22 Oz)		Air Delivery in CFM - Dry Coil (Add .08 static W/Internal Filters - Subtract 25 CFM for Wet Coil)																												
Service Driers	8 Cu In / 7 oz		230 Volt				External Static Press (Inch Water Column)				208 Volt				External Static Press (Inch Water Column)				Part No:												
			Motor Speed		0.15		0.25		0.35		0.45		0.55		0.65		0.75			Speed Tap		0.15		0.25		0.35		0.45		0.55	
Liquid/Chg	Suction																														
Unit Weight	335																														

PH5530AKA / PYPA30GA

Style No:	2.5 Ton Pkg Heat Pump		Outdoor Ambient Temperature - Degrees F. Dry Bulb																Part No:												
			75				85				95				105					115											
			Entering Indoor Temperature - Degrees F. Wet Bulb																												
Voltage	208 / 230																														
Phase/Cycles	1																														
Ampacity	21.1																														
Wire Ga/Length	NEC																														
Delay Fuse	25																														
Max. Fuse/HACR	30																														
Compressor	COPELAND																														
RLA	13.72																														
LRA	75																														
Cap MFD/V	35 / 370																														
CC Heater	N/A																														
Start Kit	NAMA001SC																														
Cond & Evap	Cond	Evap																													
Type	Fan	Blower																													
Size	20	DD10-6																													
Motor-HP	1/6	1 / 3																													
Type	PSC	PSC																													
FLA	1	2.9																													
LRA	1.72	5.6																													
RPM	1100	1075																													
Cap MFD/V	3 / 440	5 / 370																													
PTCR	N/A																														
Hi Press	N/A																														
Low Press	N/A																														
Low Amb	N/A																														
LOC Press	N/A																														
Defrost	Timed																														
Sensor	31 / 51																														
Operating Chg	(R-22 Oz)		Air Delivery in CFM - Dry Coil (Add .08 static W/Internal Filters - Subtract 25 CFM for Wet Coil)																												
Service Driers	16 Cu In / 11 oz		230 Volt				External Static Pressure (Inch Water Column)				208 Volt				External Static Pressure (Inch Water Column)				Part No:												
			Motor Speed		0.15		0.25		0.35		0.45		0.55		0.65		0.75			Speed Tap		0.15		0.25		0.35		0.45		0.55	
Liquid/Chg	Suction																														
Unit Weight	344																														

