

# **Parts List**

**Charging Chart  
Wiring Diagrams**

## **Models**

**PAS300H000BA  
PAS300L000BA  
PAS300S000BA**

# **Three Phase Single Package Air Conditioners**

**Save This Manual For Future Reference**

NOTE: This illustration is for reference only. Your unit may differ in appearance or may not include all components shown.

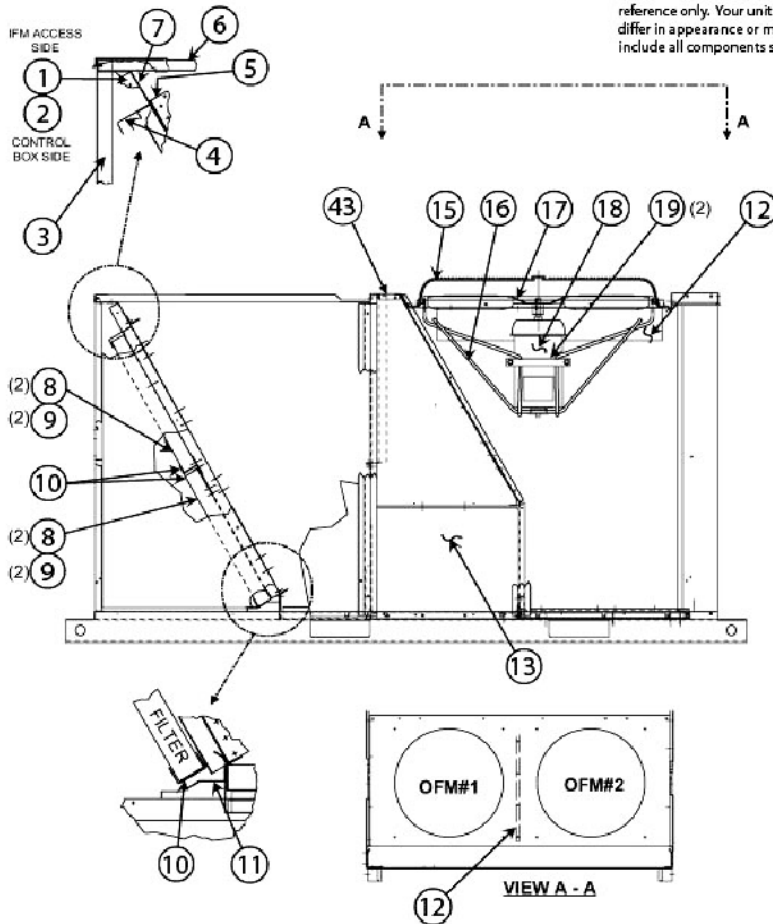

Parts Drawings ---- page 2 to 5  
 Parts list ----- page 6 to 11  
 Charging data ----- page 12 & 13  
 Wiring Diagrams--- page 14 & 16.

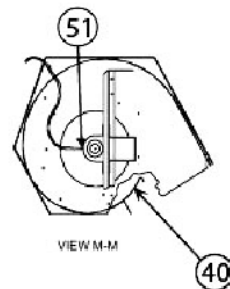
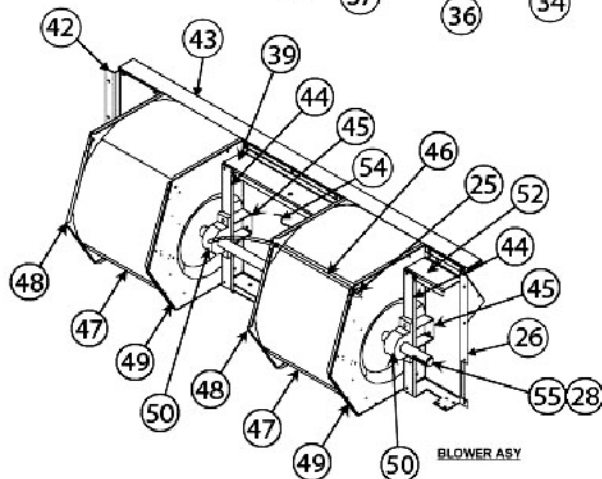
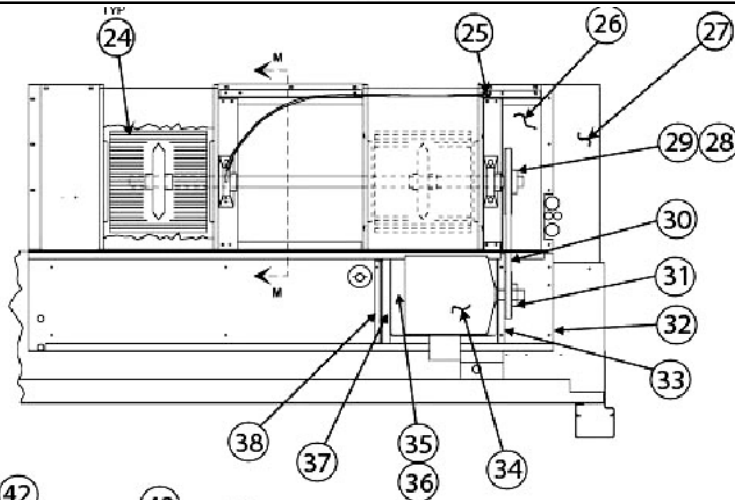

NOTE: This illustration is for reference only. Your unit may differ in appearance or may not include all components shown.

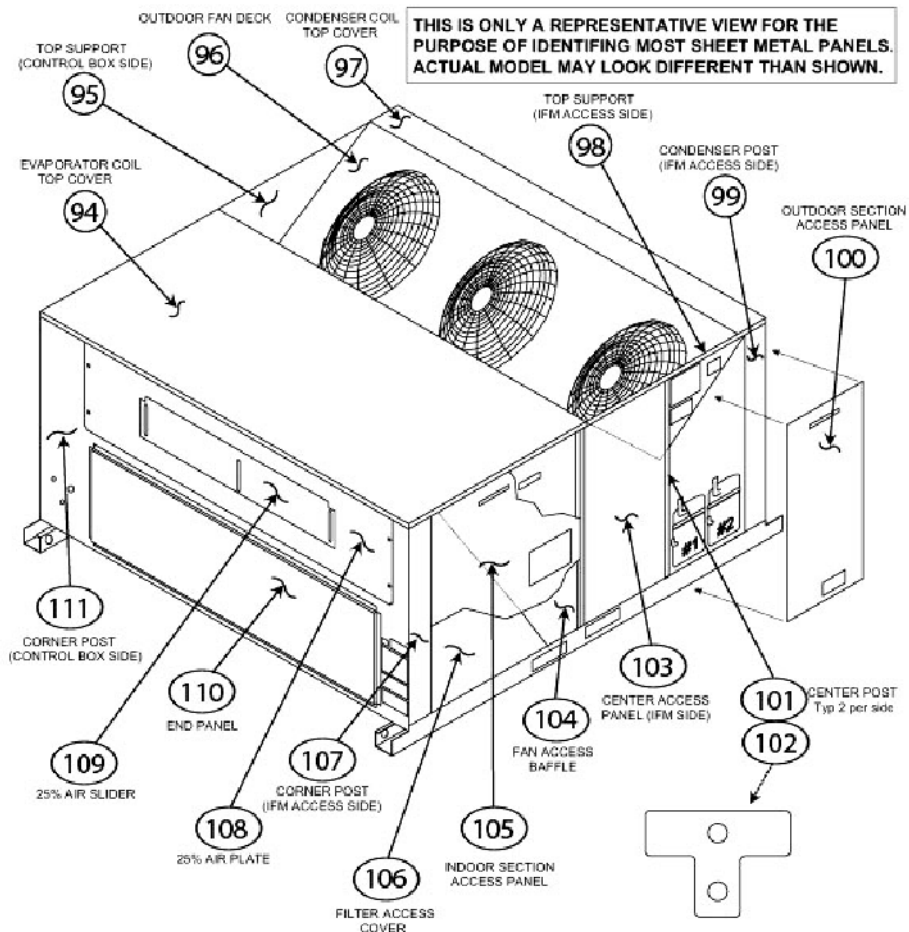
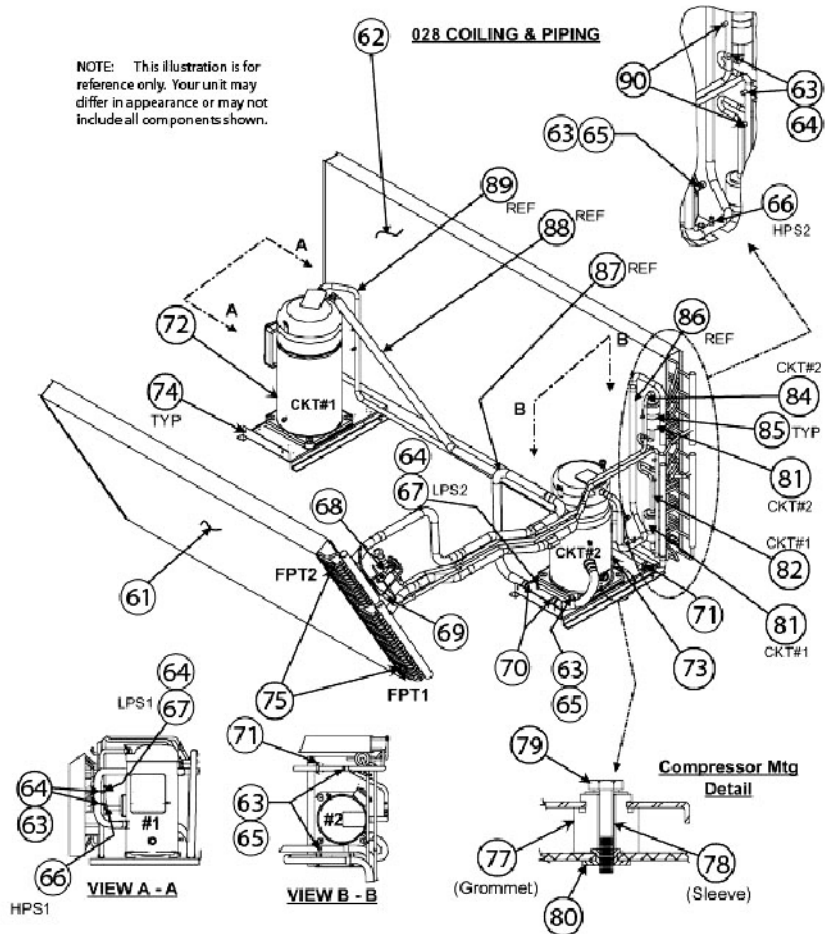

THIS IS ONLY A REPRESENTATIVE VIEW FOR THE PURPOSE OF IDENTIFYING MOST SHEET METAL PANELS. ACTUAL MODEL MAY LOOK DIFFERENT THAN SHOWN.

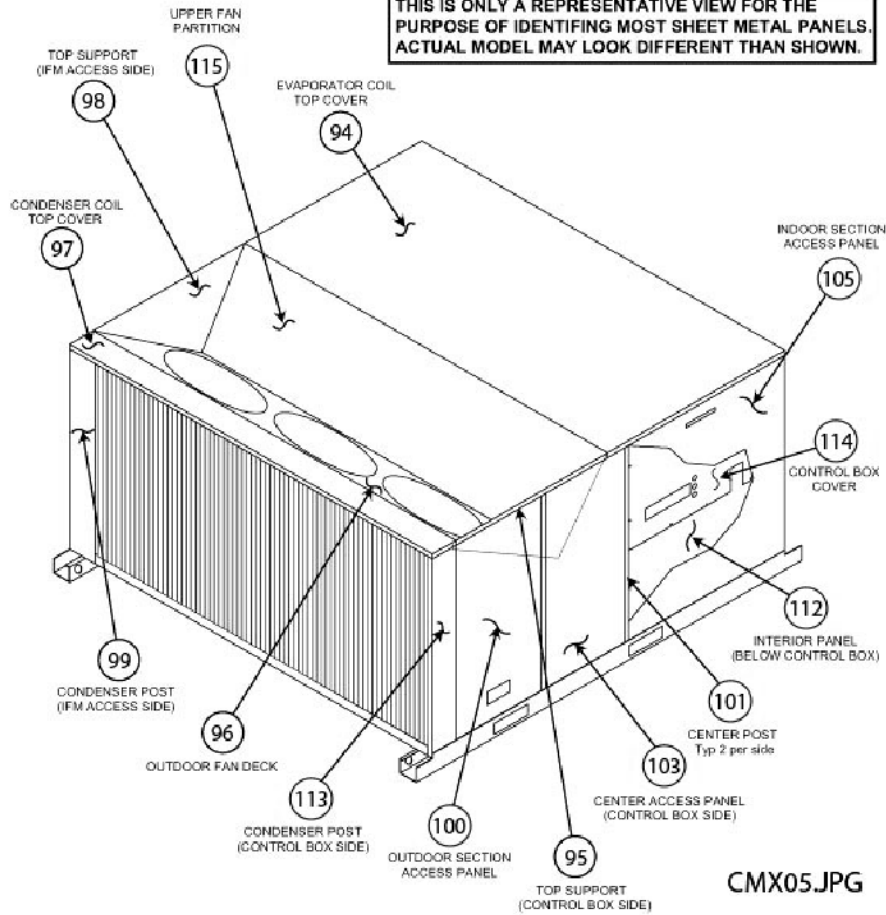

CMX05.JPG

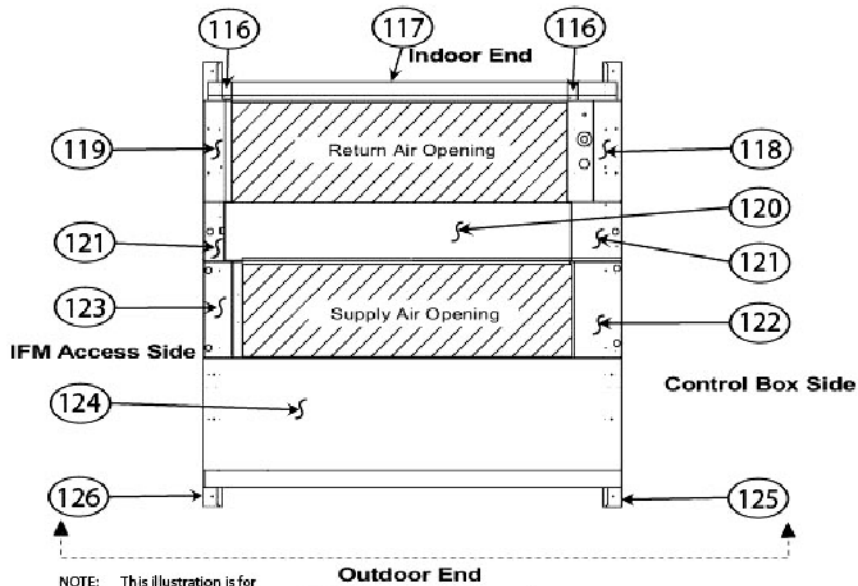

NOTE: This illustration is for reference only. Your unit may differ in appearance or may not include all components shown.

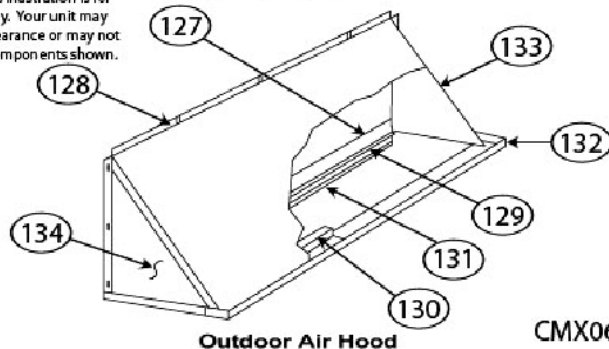

Outdoor Air Hood

CMX06.JPG

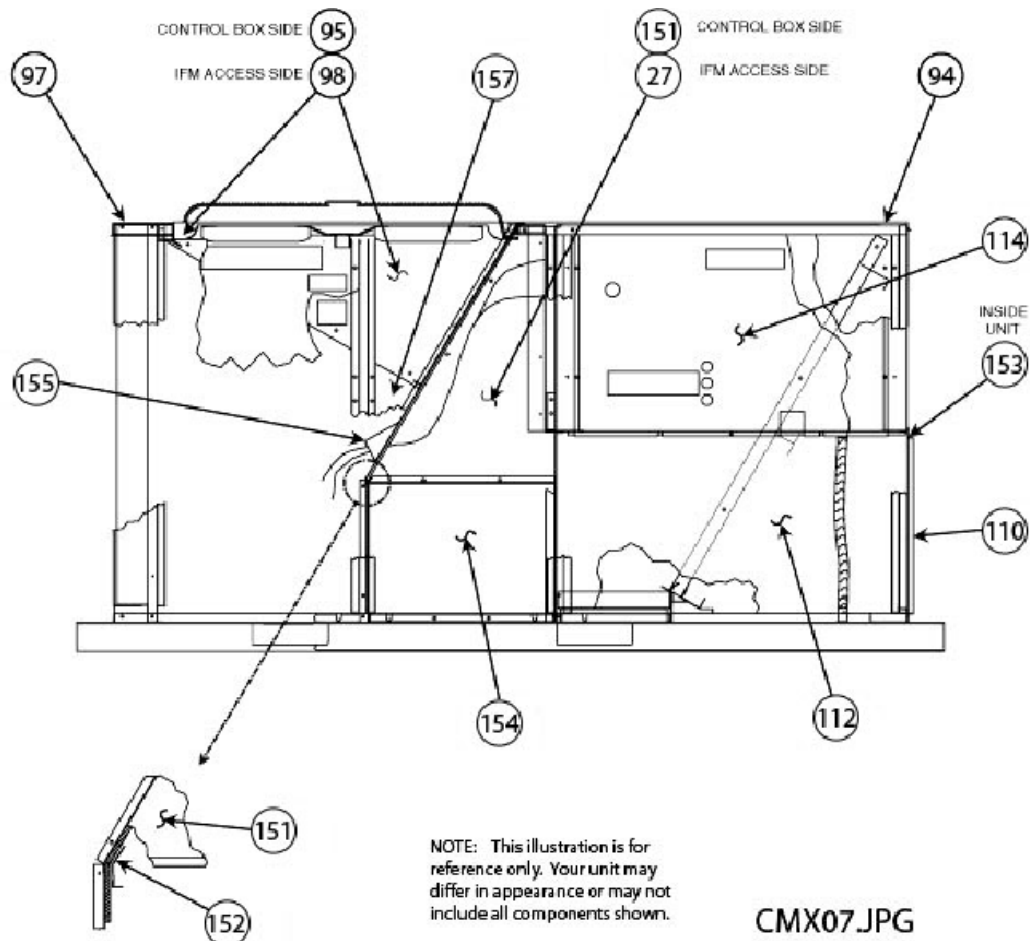

CMX07.JPG

**CONTROL BOX**

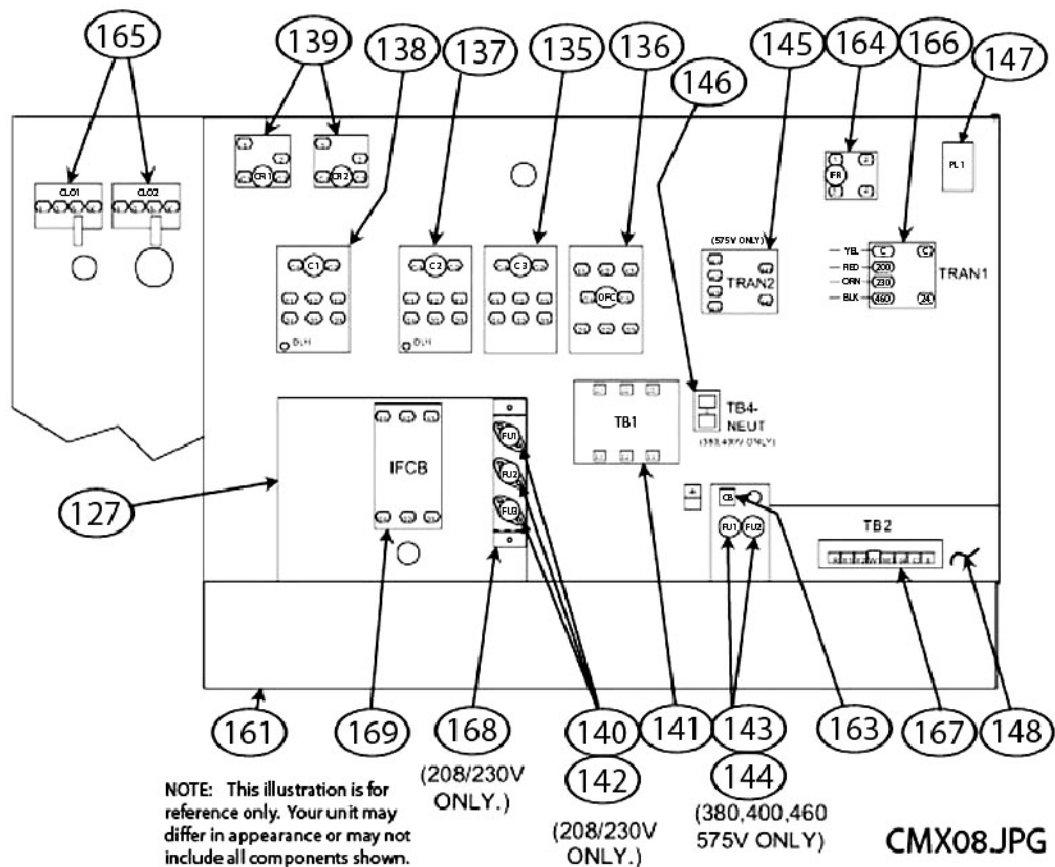

CMX08.JPG

PAS300H000BA

KEY	DESCRIPTION	PART NO	QTY
001	EVAP COIL SUPPORT,HEADER END	1172131	1
002	EVAP COIL SUPPORT,HAIRPIN END	1171468	1
003	ANGLE,SUPPORT	1171014	1
004	TRACK,FILTER	1171491	1
005	ANGLE,FILTER	1171118	1
006	UPPER BRACE,FILTER SECTION	1171060	1
007	FILTER BLOCKOFF PANEL,UPPER	1171042	1
008	FILTER,AIR	1171229	4
009	FILTER,AIR	1171010	4
010	TRACK,FILTER	1171492	3
011	SUPPORT,LOWER	1171464	1
012	BAFFLE,CONDENSER FAN	1171804	1
013	COVER,HEATER	1171290	1
015	GRILLE ASSEMBLY,OUTDOOR FAN	1171272	2
016	MOUNT ASSEMBLY,OUTDOOR FAN MOTOR	1171061	2
017	PROPELLER,OUTDOOR FAN	1171221	2
018	MOTOR,OUTDR FAN(OFM1/2)	1171869	2
019	CLAMP,OUTDOOR FAN MOTOR	1171116	4
024	BLOWER WHEEL,INDOOR	1171052	2
025	COMPRESSION CONNECTOR,FEMALE	1171138	1
026	DECK,FAN	1171215	1
027	BAFFLE,HEAT	1171283	1
028	SHAFT KEY,BLOWER PULLEY	1171321	1
029	PULLEY,STANDARD FAN	1173194	1
030	BELT,STANDARD FAN	1171811	2
031	PULLEY,STD MOTOR	1173193	1
032	UPRIGHT,INDOOR FAN MOTOR	1171226	1
033	MTR MOUNTING PLATE BRACKET,SHAFT END	1171076	1
034	MOTOR(STD/ALT)	1173180	1
035	MOUNTING PLATE,INDOOR FAN MOTOR	1171346	1
036	BOLT,IFM BELT ADJUSTMNT(5/16-18X15")	1171055	2
037	MTR MTG PLATE BRACKET,OPP SHAFT END	1171075	1
038	STOP ANGLE,MOTOR MOUNTING PLATE	1171013	1
039	BRACKET,FAN (19" ZEE CHANNEL)	1171212	1
040	CUTOFF,BLOWER	1171044	2
042	DECK,FAN	1171310	1
043	RAIL, TOP	1171490	1
044	BRACKET ASSEMBLY,BEARING	1171036	2
045	BRACKET,FAN (1 3/4" HAT CHANNEL)	1171210	2
046	LUBRICATION TUBING,ID FAN BEARING	1171501	1
047	SCROLL,FAN	1171224	2
048	FANSIDE PLATE,BEARING SIDE	1171047	2
049	FANSIDE PLATE,OPPOSITE BEARING SIDE	1171046	2
050	BEARING,INDOOR FAN	1171034	2
051	COMPRESSION CONNECTOR,MALE	1171157	1
052	BRACKET,FAN (7" ZEE CHANNEL)	1171211	1
054	DECK,FAN	1171213	1
055	SHAFT,FAN	1171225	1
061	INDOOR COIL ASY,ALUMINUM FIN	1173170	1

KEY	DESCRIPTION	PART NO	QTY
062	OUTDOOR COIL ASY,ALUMINUM FIN	1173191	1
063	CAP,FLARE	1171101	8
064	CORE,SCHRAEDER VALVE	1171508	6
065	CORE,VALVE(SEE IT 2380)	1173177	4
066	SWITCH,PRESSURE (HPS1)(HPS2)	1172381	2
067	SWITCH,PRESSURE (LPS1)(LPS2)	1171868	2
068	VALVE,TXV	1173173	1
069	VALVE,TXV	1172595	1
070	CLAMP	1172436	2
071	CLAMP	1171115	2
072	COMPRESSOR,#1	1173195	1
073	COMPRESSOR,#2	1172880	1
075	THERMOSTAT,FREEZE PROTECTION (FPT)	1171252	2
081	FILTER DRIER,SYSTEM #1/2	1171203	2
085	STRAP,FILTER DRIER	1172133	2
090	PLUG,FUSIBLE(LIQUID LINES)	1171403	2
094	TOP COVER,EVAPORATOR	1171360	1
095	TOP SUPPORT,CONTROL BOX SIDE	1171465	1
096	FAN DECK,OUTDOOR	1171355	1
097	TOP COVER,CONDENSER COIL	1171489	1
098	TOP SUPPORT,IFM ACCESS SIDE	1171847	1
099	POST,CONDENSER (IFM ACCESS SIDE)	1171176	1
100	ACCESS PANEL,OUTDOOR SECTION	1171377	2
101	POST,CENTER (TWO PER SIDE)	1171083	4
102	LATCH ASSEMBLY	1171019	8
103	ACCESS PANEL,CENTER	1171378	2
104	BAFFLE,FAN ACCESS	1171209	1
105	ACCESS PANEL,INDOOR SECTION	1171379	2
106	COVER,FILTER ACCESS	1171319	1
107	CORNER POST,IFM ACCESS SIDE	1171408	1
108	PLATE,25% AIR	1171392	1
109	SLIDER,25% AIR	1171457	1
110	PANEL,END (NO PWR EXH/BAR RELIEF)	1171361	1
111	CORNER POST,CONTROL BOX SIDE	1171171	1
112	BAFFLE ASSEMBLY,CONTROL BOX END	1171017	1
113	POST,CONDENSER (CONTROL BOX SIDE)	1171411	1
114	COVER,CONTROL BOX	1171316	1
115	PARTITION,FAN	1171217	1
116	ANGLE,BASE RAIL	1171029	2
117	BASE RAIL,INDOOR END	1171030	1
118	FILTER PAN,CONTROL BOX SIDE	1171236	1
119	FILTER PAN,IFM ACCESS SIDE	1171237	1
120	PAN,CONDENSATE	1171517	1
121	BASE PAN,EVAPORATOR SECTION	1171021	1
122	HEATER PAN,CONTROL BOX SIDE	1171292	1
123	HEATER PAN,IFM ACCESS SIDE	1171291	1
124	BASE PAN,CONDENSER SECTION	1171022	1
125	BASE RAIL,CONTROL BOX SIDE	1171028	1
126	BASE RAIL,INDOOR ACCESS SIDE	1171027	1
127	BAFFLE	1171016	1

## PAS300H000BA

KEY	DESCRIPTION	PART NO	QTY
128	TOP COVER,HOOD	1171183	1
129	BRACKET,FILTER	1171241	1
130	ANGLE,FILTER	1171015	1
131	BRACKET,FILTER	1171084	1
132	DRAIN PAN,HOOD	1171358	1
133	RIGHT HOOD SIDE,OUTSIDE AIR	1171380	1
134	LEFT HOOD SIDE,OUTSIDE AIR	1171381	1
135	CONTACTOR,INDOOR FAN (IFC)	1173183	1
136	CONTACTOR,OUTDOOR FAN (OFC)	1171160	1
137	CONTACTOR,COMPRESSOR (C2)	1171162	1
138	CONTACTOR,COMPRESSOR (C2)	1171162	1
139	RELAY,CONTROL (CR1)(CR2)	1171436	3
140	FUSE (FU1)(FU2)(FU3)	1171253	3
141	TERMINAL BLOCK #1 (TB1)	1171485	2
142	FUSE HOLDER (FU1)(FU2)(FU3)	1171259	3
147	PLUG(ECON PL1)(12PIN)	1171401	1
151	BAFFLE,HEAT	1171881	1
152	RETAINER,FAN PARTITION	1171204	1
153	CHANNEL,DUCT	1171111	1
154	COVER,HEATER	1171178	1
155	WIRE COVER,OUTDOOR FAN MOTOR	1171273	1
157	PLATE,BLOCKOFF	1171366	2
161	CONTROL BOX	1171167	1
162	BRKT,CIRC BRKR (CB1,2/IFCB)	1172140	1
163	CIRCUIT BREAKER,CONTROL (CB)	1171114	1
164	RELAY,CONTROL (CR1)(CR2)	1171436	1
165	RELAY,COMP LOCKOUT(CLO1)(CLO2)	1171437	2
166	TRANSFORMER #1 (TRAN1)	1171498	1
167	TERMINAL BOARD #2 (TB2)	1173187	1
168	BRACKET,FUSE (FU1,2,3)	1171256	1
169	CIRCUIT BREAKER (IFCB)	1173182	1
)	FILTER,ALUMINUM MESH (20X20X1)	1171243	1
)	COMPRESSOR GASKET	1173168	1
)	TUBE,TVX	1173169	1
)	DISTRIBUTOR	1173174	1
)	NOZZLE	1173175	1
)	BODY,VALVE	1173176	4
)	HEATER,CRANKCASE (CH1/2)	1173185	2
)	CONDUIT,CONTL BOX POWER IN	1173188	3
)	SIGHT GLASS	1173192	1
)	COMPRESSOR OIL	1173198	1
)	COUPLING,HALF	1171009	2
)	FILTER ANGLE,OUTSIDE AIR HOOD	1171085	1
)	BOLT,INDOOR FAN MOTOR JACKING PLATE	1171103	5
)	TUBE,FEEDER	1171228	40
)	FILTER PACKAGE,OUTSIDE AIR HOOD	1171235	1
)	FILTER,ALUMINUM MESH (20X25X1)	1171244	2
)	HOOD ASSEMBLY,OUTDOOR AIR	1171298	1
)	NOZZLE	1171352	1
)	PAINT,TOUCH UP	1171357	1

KEY	DESCRIPTION	PART NO	QTY
)	JACKING PLATE,INDOOR FAN MOTOR	1171400	1
)	PLUG ASSEMBLY (NO ECONOMIZER)(REF)	1171404	1
)	CONNECTOR,RECEPTACLE (PL1)	1171430	1
)	SPACER,FILTER	1171458	1
)	PLATE,SPACER	1171459	1
)	VALVE BODY,SCHRAEDER	1171507	8
)	CONNECTOR	1171822	1
)	DISTRIBUTOR	1171851	1
)	RETAINER,OUTER FANSIDE PLATE	1172134	2

## PAS300L000BA

KEY	DESCRIPTION	PART NO	QTY
001	EVAP COIL SUPPORT,HEADER END	1172131	1
002	EVAP COIL SUPPORT,HAIRPIN END	1171468	1
003	ANGLE,SUPPORT	1171014	1
004	TRACK,FILTER	1171491	1
005	ANGLE,FILTER	1171118	1
006	UPPER BRACE,FILTER SECTION	1171060	1
007	FILTER BLOCKOFF PANEL,UPPER	1171042	1
008	FILTER,AIR	1171229	4
009	FILTER,AIR	1171010	4
010	TRACK,FILTER	1171492	3
011	SUPPORT,LOWER	1171464	1
012	BAFFLE,CONDENSER FAN	1171804	1
013	COVER,HEATER	1171290	1
015	GRILLE ASSEMBLY,OUTDOOR FAN	1171272	2
016	MOUNT ASSEMBLY,OUTDOOR FAN MOTOR	1171061	2
017	PROPELLER,OUTDOOR FAN	1171221	2
018	MOTOR,OUTDR FAN(OFM1/2)	1171869	2
019	CLAMP,OUTDOOR FAN MOTOR	1171116	4
024	BLOWER WHEEL,INDOOR	1171052	2
025	COMPRESSION CONNECTOR,FEMALE	1171138	1
026	DECK,FAN	1171215	1
027	BAFFLE,HEAT	1171283	1
028	SHAFT KEY,BLOWER PULLEY	1171321	1
029	PULLEY,STANDARD FAN	1173194	1
030	BELT,STANDARD FAN	1171811	2
031	PULLEY,STD MOTOR	1173193	1
032	UPRIGHT,INDOOR FAN MOTOR	1171226	1
033	MTR MOUNTING PLATE BRACKET,SHAFT END	1171076	1
034	MOTOR(STD/ALT)	1173180	1
035	MOUNTING PLATE,INDOOR FAN MOTOR	1171346	1
036	BOLT,IFM BELT ADJUSTMNT(5/16-18X15")	1171055	2
037	MTR MTG PLATE BRACKET,OPP SHAFT END	1171075	1
038	STOP ANGLE,MOTOR MOUNTING PLATE	1171013	1
039	BRACKET,FAN (19" ZEE CHANNEL)	1171212	1
040	CUTOFF,BLOWER	1171044	2
042	DECK,FAN	1171310	1
043	RAIL,TOP	1171490	1
044	BRACKET ASSEMBLY,BEARING	1171036	2
045	BRACKET,FAN (1 3/4" HAT CHANNEL)	1171210	2
046	LUBRICATION TUBING,ID FAN BEARING	1171501	1
047	SCROLL,FAN	1171224	2
048	FANSIDE PLATE,BEARING SIDE	1171047	2
049	FANSIDE PLATE,OPPOSITE BEARING SIDE	1171046	2
050	BEARING,INDOOR FAN	1171034	2
051	COMPRESSION CONNECTOR,MALE	1171157	1
052	BRACKET,FAN (7" ZEE CHANNEL)	1171211	1
054	DECK,FAN	1171213	1
055	SHAFT,FAN	1171225	1
061	INDOOR COIL ASY,ALUMINUM FIN	1173170	1

KEY	DESCRIPTION	PART NO	QTY
062	OUTDOOR COIL ASY,ALUMINUM FIN	1173191	1
063	CAP,FLARE	1171101	8
064	CORE,SCHRAEDER VALVE	1171508	6
065	CORE,VALVE	1173177	4
066	SWITCH,PRESSURE (HPS1)(HPS2)	1172381	2
067	SWITCH,PRESSURE (LPS1)(LPS2)	1171868	2
068	VALVE,TVX	1173173	1
069	VALVE,TVX	1172595	1
070	CLAMP	1172436	2
071	CLAMP	1171115	2
072	COMPRESSOR,#1	1173196	1
073	COMPRESSOR,#2	1172879	1
075	THERMOSTAT,FREEZE PROTECTION (FPT)	1171252	2
081	FILTER DRIER,SYSTEM #12	1171203	2
085	STRAP,FILTER DRIER	1172133	2
090	PLUG,FUSIBLE(LIQUID LINES)	1171403	2
094	TOP COVER,EVAPORATOR	1171360	1
095	TOP SUPPORT,CONTROL BOX SIDE	1171465	1
096	FAN DECK,OUTDOOR	1171355	1
097	TOP COVER,CONDENSER COIL	1171489	1
098	TOP SUPPORT,IFM ACCESS SIDE	1171847	1
099	POST,CONDENSER (IFM ACCESS SIDE)	1171176	1
100	ACCESS PANEL,OUTDOOR SECTION	1171377	2
101	POST,CENTER (TWO PER SIDE)	1171083	4
102	LATCH ASSEMBLY	1171019	8
103	ACCESS PANEL,CENTER	1171378	2
104	BAFFLE,FAN ACCESS	1171209	1
105	ACCESS PANEL,INDOOR SECTION	1171379	2
106	COVER,FILTER ACCESS	1171319	1
107	CORNER POST,IFM ACCESS SIDE	1171408	1
108	PLATE,25% AIR	1171392	1
109	SLIDER,25% AIR	1171457	1
110	PANEL,END (NO PWR EXH/BAR RELIEF)	1171361	1
111	CORNER POST,CONTROL BOX SIDE	1171171	1
112	BAFFLE ASSEMBLY,CONTROL BOX END	1171017	1
113	POST,CONDENSER (CONTROL BOX SIDE)	1171411	1
115	PARTITION,FAN	1171217	1
116	ANGLE,BASE RAIL	1171029	2
117	BASE RAIL,INDOOR END	1171030	1
118	FILTER PAN,CONTROL BOX SIDE	1171236	1
119	FILTER PAN,IFM ACCESS SIDE	1171237	1
120	PAN,CONDENSATE	1171517	1
121	BASE PAN,EVAPORATOR SECTION	1171021	1
122	HEATER PAN,CONTROL BOX SIDE	1171292	1
123	HEATER PAN,IFM ACCESS SIDE	1171291	1
123	PLATE,BLOCKOFF	1171366	2
124	BASE PAN,CONDENSER SECTION	1171022	1
125	BASE RAIL,CONTROL BOX SIDE	1171028	1
126	BASE RAIL,INDOOR ACCESS SIDE	1171027	1
127	BAFFLE	1171016	1



PAS300L000BA

KEY	DESCRIPTION	PART NO	QTY
128	TOP COVER,HOOD	1171183	1
129	BRACKET,FILTER	1171241	1
130	ANGLE,FILTER	1171015	1
131	BRACKET,FILTER	1171084	1
132	DRAIN PAN,HOOD	1171358	1
133	RIGHT HOOD SIDE,OUTSIDE AIR	1171380	1
134	LEFT HOOD SIDE,OUTSIDE AIR	1171381	1
135	CONTACTOR (IFC) (C1/C2)	1172449	1
136	CONTACTOR,OUTDOOR FAN (OFC)	1173184	1
137	CONTACTOR (IFC) (C1/C2)	1172449	1
138	CONTACTOR (IFC) (C1/C2)	1172449	1
139	RELAY,CONTROL (CR1)(CR2)	1171813	2
141	TERMINAL BLOCK #1 (TB1)	1171486	2
143	FUSE (FU1) (FU2)	1171098	2
144	FUSE HOLDER (FU1)(FU2)	1171258	2
147	PLUG(ECON PL1)(12PIN)	1171401	1
151	BAFFLE,HEAT	1171881	1
152	RETAINER,FAN PARTITION	1171204	1
153	CHANNEL,DUCT	1171111	1
154	COVER,HEATER	1171178	1
155	WIRE COVER,OUTDOOR FAN MOTOR	1171273	1
161	CONTROL BOX	1171167	1
162	BRKT,CIRC BRKR (CB1,2/IFCB)	1172140	1
163	CIRCUIT BREAKER,CONTROL (CB)	1171114	1
164	RELAY,INDOOR FAN (IFR)	1171436	1
165	RELAY,COMP LOCKOUT(CLO1)(CLO2)	1171437	2
166	TRANSFORMER #1 (TRAN1)	1171498	1
167	TERMINAL BOARD #2 (TB2)	1173187	1
169	CIRCUIT BREAKER (IFCB)	1171816	1
)	FILTER,ALUMINUM MESH (20X20X1)	1171243	1
)	COMPRESSOR GASKET	1173168	1
)	TUBE,TVX	1173169	1
)	DISTRIBUTOR	1173174	1
)	NOZZLE	1173175	1
)	BODY,VALVE	1173176	4
)	HEATER,CRANKCASE (CH1/2)	1173186	2
)	CONDUIT,CONTL BOX POWER IN	1173188	3
)	SIGHT GLASS	1173192	1
)	COMPRESSOR OIL	1173198	1
)	COUPLING,HALF	1171009	2
)	FILTER ANGLE,OUTSIDE AIR HOOD	1171085	1
)	BOLT,INDOOR FAN MOTOR JACKING PLATE	1171103	5
)	TUBE,FEEDER	1171228	40
)	FILTER PACKAGE,OUTSIDE AIR HOOD	1171235	1
)	FILTER,ALUMINUM MESH (20X25X1)	1171244	2
)	HOOD ASSEMBLY,OUTDOOR AIR	1171298	1
)	NOZZLE	1171352	1
)	PAINT,TOUCH UP	1171357	1
)	JACKING PLATE,INDOOR FAN MOTOR	1171400	1
)	PLUG ASSEMBLY (NO ECONOMIZER)(REF)	1171404	1

KEY	DESCRIPTION	PART NO	QTY
)	CONNECTOR,RECEPTACLE (PL1)	1171430	1
)	SPACER,FILTER	1171458	1
)	PLATE,SPACER	1171459	1
)	VALVE BODY,SCHRAEDER	1171507	8
)	CONNECTOR	1171822	1
)	DISTRIBUTOR	1171851	1
)	COVER,CONTROL BOX	1171882	1
)	RETAINER,OUTER FANSIDE PLATE	1172134	2

PAS300S000BA

KEY	DESCRIPTION	PART NO	QTY
001	EVAP COIL SUPPORT,HEADER END	1172131	1
002	EVAP COIL SUPPORT,HAIRPIN END	1171468	1
003	ANGLE,SUPPORT	1171014	1
004	TRACK,FILTER	1171491	1
005	ANGLE,FILTER	1171118	1
006	UPPER BRACE,FILTER SECTION	1171060	1
007	FILTER BLOCKOFF PANEL,UPPER	1171042	1
008	FILTER,AIR	1171229	4
009	FILTER,AIR	1171010	4
010	TRACK,FILTER	1171492	3
011	SUPPORT,LOWER	1171464	1
012	BAFFLE,CONDENSER FAN	1171804	1
013	COVER,HEATER	1171290	1
015	GRILLE ASSEMBLY,OUTDOOR FAN	1171272	2
016	MOUNT ASSEMBLY,OUTDOOR FAN MOTOR	1171061	2
017	PROPELLER,OUTDOOR FAN	1171221	2
018	MOTOR,OUTDR FAN(OFM1/2)	1173178	2
019	CLAMP,OUTDOOR FAN MOTOR	1171116	4
024	BLOWER WHEEL,INDOOR	1171052	2
025	COMPRESSION CONNECTOR,FEMALE	1171138	1
026	DECK,FAN	1171215	1
027	BAFFLE,HEAT	1171283	1
028	SHAFT KEY,BLOWER PULLEY	1171321	1
029	PULLEY,STANDARD FAN	1173194	1
030	BELT,STANDARD FAN	1171811	2
031	PULLEY,STD MOTOR	1173193	1
032	UPRIGHT,INDOOR FAN MOTOR	1171226	1
033	MTR MOUNTING PLATE BRACKET,SHAFT END	1171076	1
034	MOTOR(STD/ALT)	1173179	1
035	MOUNTING PLATE,INDOOR FAN MOTOR	1171346	1
036	BOLT,IFM BELT ADJUSTMNT(5/16-18X15")	1171055	2
037	MTR MTG PLATE BRACKET,OPP SHAFT END	1171075	1
038	STOP ANGLE,MOTOR MOUNTING PLATE	1171013	1
039	BRACKET,FAN (19" ZEE CHANNEL)	1171212	1
040	CUTOFF,BLOWER	1171044	2
042	DECK,FAN	1171310	1
043	RAIL, TOP	1171490	1
044	BRACKET ASSEMBLY,BEARING	1171036	2
045	BRACKET,FAN (1 3/4" HAT CHANNEL)	1171210	2
046	LUBRICATION TUBING,ID FAN BEARING	1171501	1
047	SCROLL,FAN	1171224	2
048	FANSIDE PLATE,BEARING SIDE	1171047	2
049	FANSIDE PLATE,OPPOSITE BEARING SIDE	1171046	2
050	BEARING,INDOOR FAN	1171034	2
051	COMPRESSION CONNECTOR,MALE	1171157	1
052	BRACKET,FAN (7" ZEE CHANNEL)	1171211	1
054	DECK,FAN	1171213	1
055	SHAFT,FAN	1171225	1
061	INDOOR COIL ASY,ALUMINUM FIN	1173170	1

KEY	DESCRIPTION	PART NO	QTY
062	OUTDOOR COIL ASY,ALUMINUM FIN	1173191	1
063	CAP,FLARE	1171101	8
064	CORE,SCHRAEDER VALVE	1171508	6
065	CORE,VALVE	1173177	4
066	SWITCH,PRESSURE (HPS1)(HPS2)	1172381	2
067	SWITCH,PRESSURE (LPS1)(LPS2)	1171868	2
068	VALVE,TVX	1173173	1
069	VALVE,TVX	1172595	1
070	CLAMP	1172436	2
071	CLAMP	1171115	2
072	COMPRESSOR,#1	1173197	1
073	COMPRESSOR,#2	1172878	1
075	THERMOSTAT,FREEZE PROTECTION (FPT)	1171252	2
081	FILTER DRIER,SYSTEM #1 (LOWER)	1171203	2
085	STRAP,FILTER DRIER	1172133	2
090	PLUG,FUSIBLE(LIQUID LINES)	1171403	2
094	TOP COVER,EVAPORATOR	1171360	1
095	TOP SUPPORT,CONTROL BOX SIDE	1171465	1
096	FAN DECK,OUTDOOR	1171355	1
097	TOP COVER,CONDENSER COIL	1171489	1
098	TOP SUPPORT,IFM ACCESS SIDE	1171847	1
099	POST,CONDENSER (IFM ACCESS SIDE)	1171176	1
100	ACCESS PANEL,OUTDOOR SECTION	1171377	2
101	POST,CENTER (TWO PER SIDE)	1171083	4
102	LATCH ASSEMBLY	1171019	8
103	ACCESS PANEL,CENTER	1171378	2
104	BAFFLE,FAN ACCESS	1171209	1
105	ACCESS PANEL,INDOOR SECTION	1171379	2
106	COVER,FILTER ACCESS	1171319	1
107	CORNER POST,IFM ACCESS SIDE	1171408	1
108	PLATE,25% AIR	1171392	1
109	SLIDER,25% AIR	1171457	1
110	PANEL,END	1171361	1
111	CORNER POST,CONTROL BOX SIDE	1171171	1
112	BAFFLE ASSEMBLY,CONTROL BOX END	1171017	1
113	POST,CONDENSER (CONTROL BOX SIDE)	1171411	1
115	PARTITION,FAN	1171217	1
116	ANGLE,BASE RAIL	1171029	2
117	BASE RAIL,INDOOR END	1171030	1
118	FILTER PAN,CONTROL BOX SIDE	1171236	1
119	FILTER PAN,IFM ACCESS SIDE	1171237	1
120	PAN,CONDENSATE	1171517	1
121	BASE PAN,EVAPORATOR SECTION	1171021	1
122	HEATER PAN,CONTROL BOX SIDE	1171292	1
123	HEATER PAN,IFM ACCESS SIDE	1171291	1
123	PLATE,BLOCKOFF	1171366	2
124	BASE PAN,CONDENSER SECTION	1171022	1
125	BASE RAIL,CONTROL BOX SIDE	1171028	1
126	BASE RAIL,INDOOR ACCESS SIDE	1171027	1
127	BAFFLE	1171016	1

PAS300S000BA

KEY	DESCRIPTION	PART NO	QTY
128	TOP COVER,HOOD	1171183	1
129	BRACKET,FILTER	1171241	1
130	ANGLE,FILTER	1171015	1
131	BRACKET,FILTER	1171084	1
132	DRAIN PAN,HOOD	1171358	1
133	RIGHT HOOD SIDE,OUTSIDE AIR	1171380	1
134	LEFT HOOD SIDE,OUTSIDE AIR	1171381	1
135	CONTACTOR,INDOOR FAN (IFC)	1172449	1
136	CONTACTOR,OUTDOOR FAN (OFC)	1173184	1
137	CONTACTOR,(C2)	1172449	1
138	CONTACTOR,(C1)	1172449	1
139	RELAY,CONTROL (CR1)(CR2)	1171813	2
141	TERMINAL BLOCK #1 (TB1)	1171486	2
143	FUSE (FU1) (FU2)	1171098	2
144	FUSE HOLDER (FU1)(FU2)	1171258	2
145	TRANSFORMER #2 (TRAN2)	1171837	1
147	PLUG(ECON PL1)(12PIN)	1171401	1
151	BAFFLE,HEAT	1171881	1
152	RETAINER,FAN PARTITION	1171204	1
153	CHANNEL,DUCT	1171111	1
154	COVER,HEATER	1171178	1
155	WIRE COVER,OUTDOOR FAN MOTOR	1171273	1
161	CONTROL BOX	1171167	1
162	BRKT,CIRC BRKR (CB1,2/IFCB)	1172140	1
163	CIRCUIT BREAKER,CONTROL (CB)	1171114	1
164	RELAY,INDOOR FAN (IFR)	1171436	1
165	ELAY,COMP LOCKOUT(CLO1)(CLO2)	1171437	2
166	TRANSFORMER #1 (TRAN1)	1171498	1
167	TERMINAL BOARD #2 (TB2)	1173187	1
169	CIRCUIT BREAKER (IFCB)	1171081	1
)	FILTER,ALUMINUM MESH (20X20X1)	1171243	1
)	COMPRESSOR GASKET	1173168	1
)	TUBE,TVX	1173169	1
)	DISTRIBUTOR	1173174	1
)	NOZZLE	1173175	1
)	BODY,VALVE	1173176	4
)	HEATER,CRANKCASE (CH1/2)	1173185	2
)	SIGHT GLASS	1173192	1
)	COMPRESSOR OIL	1173198	1
)	COUPLING,HALF	1171009	2
)	FILTER ANGLE,OUTSIDE AIR HOOD	1171085	1
)	BOLT,INDOOR FAN MOTOR JACKING PLATE	1171103	5
)	TUBE,FEEDER	1171228	40
)	FILTER PACKAGE,OUTSIDE AIR HOOD	1171235	1
)	FILTER,ALUMINUM MESH (20X25X1)	1171244	2
)	HOOD ASSEMBLY,OUTDOOR AIR	1171298	1
)	NOZZLE	1171352	1
)	PAINT,TOUCH UP	1171357	1
)	JACKING PLATE,INDOOR FAN MOTOR	1171400	1
)	PLUG ASSEMBLY (NO ECONOMIZER)(REF)	1171404	1

KEY	DESCRIPTION	PART NO	QTY
)	CONNECTOR,RECEPTACLE (PL1)	1171430	1
)	SPACER,FILTER	1171458	1
)	PLATE,SPACER	1171459	1
)	VALVE BODY,SCHRAEDER	1171507	8
)	CONNECTOR	1171822	1
)	DISTRIBUTOR	1171851	1
)	COVER,CONTROL BOX	1171882	1
)	RETAINER,OUTER FANSIDE PLATE	1172134	2
)	CONDUIT,CONTL BOX POWER IN	1172138	1

## PAS300 Cooling Charging Chart

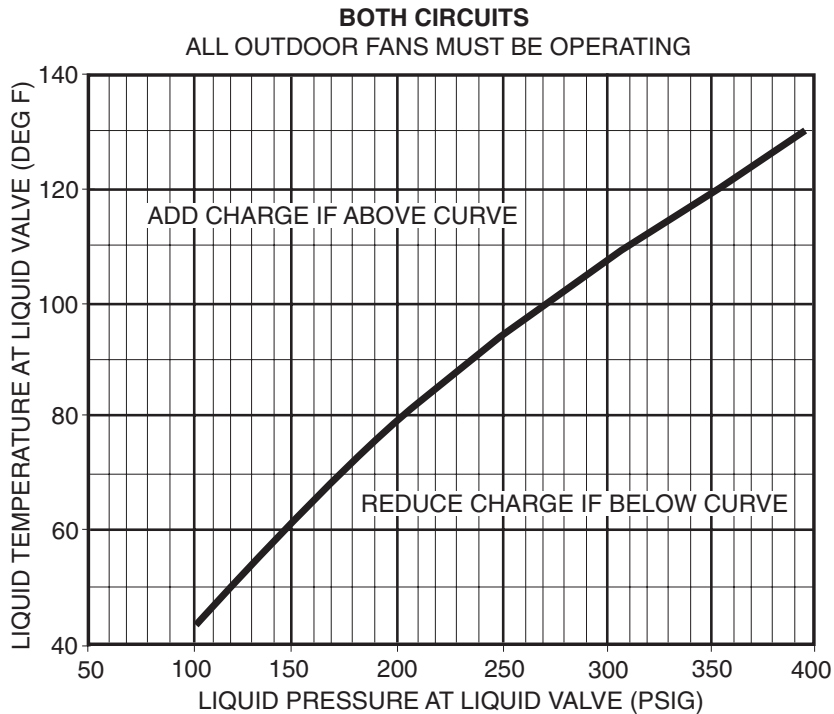

**TO USE THE COOLING CHARGING CHART** - Use the above temperature and pressure readings, and find the intersection point on the cooling charging chart. If intersection point on chart is above line, add refrigerant. If intersection point on chart is below line, carefully recover some of the charge. Re-check suction pressure as charge is adjusted.

**Note:** Indoor-air cfm must be within normal operating range of unit. All outdoor fans must be operating.

The TXV is set to maintain between 15 and 20 degrees of super-heat at the compressors. The valves are factory set and should not require re-adjustment.

**EXPANDED PERFORMANCE DATA (COOLING) 25 TON (GROSS CAPACITY)**

Temp (F) Air Entering Condenser (Edb)		Evaporator Air Quantity - CFM													
		8,000							9,000						
		Evaporator Air - Ewb (F)/BF													
		54/0.49	58/0.32	62/0.15	67/0.14	72/0.13	76/0.17	80/0.00	54/0.53	58/0.37	62/0.18	67/0.15	72/0.14	76/0.17	80/0.00
75	TC	266	268	280	304	324	352	379	277	276	286	310	336	361	385
	SHC	266	251	246	209	168	137	107	277	269	261	221	178	142	108
	kW	19.5	19.6	19.9	20.5	20.9	21.8	22.4	19.8	19.5	20.0	20.6	21.3	22.0	22.6
85	TC	260	262	272	294	321	344	367	271	272	277	300	326	349	373
	SHC	260	254	243	205	167	135	104	271	264	257	217	175	139	104
	kW	21.6	21.6	22.0	22.5	23.3	23.9	24.6	22.2	21.9	22.1	22.7	23.4	24.1	24.8
95	TC	254	256	262	284	310	332	355	263	263	268	289	316	337	360
	SHC	254	249	238	201	163	131	100	263	263	251	213	171	135	100
	kW	23.8	23.9	24.1	24.8	25.5	26.2	26.9	24.1	24.1	24.3	24.9	25.9	26.4	27.1
105	TC	246	247	253	274	298	319	343	255	255	258	278	302	326	346
	SHC	246	245	233	197	159	127	96	255	255	246	208	166	132	96
	kW	26.3	26.3	26.5	27.2	28.0	28.7	29.5	26.5	26.5	26.6	27.3	28.1	29.0	29.6
115	TC	238	239	243	264	286	306	328	247	246	249	267	290	311	-
	SHC	238	239	228	193	155	123	91	247	246	239	204	162	127	-
	kW	28.9	28.9	29.1	29.7	30.6	31.4	32.1	29.1	29.2	29.3	30.0	30.8	31.5	-

**EXPANDED PERFORMANCE DATA (COOLING) 25 TON (GROSS CAPACITY) Cont.**

Temp (F) Air Entering Condenser (Edb)		Evaporator Air Quantity - CFM													
		10,000							11,250						
		Evaporator Air - Ewb (F)/BF													
		54/0.57	58/0.41	62/0.23	67/0.16	72/0.15	76/0.17	80/0.00	54/0.61	58/0.47	62/0.30	67/0.16	72/0.17	76/0.17	80/0.00
75	TC	286	284	291	314	341	365	390	295	295	298	319	342	367	392
	SHC	286	284	274	232	186	147	108	295	295	285	245	193	151	108
	kW	20.0	20.2	20.2	20.8	21.5	22.1	22.7	20.3	20.3	20.4	20.9	21.2	21.5	21.9
85	TC	278	278	282	304	330	354	378	288	287	289	310	334	359	384
	SHC	278	278	269	228	182	143	105	288	287	278	241	190	148	106
	kW	22.1	22.1	22.2	22.8	23.6	24.2	24.9	22.5	22.4	22.4	23.1	23.7	24.4	25.3
95	TC	270	270	273	293	319	341	364	278	278	280	318	323	346	-
	SHC	270	270	262	223	177	139	101	278	278	269	150	186	144	-
	kW	24.4	24.4	24.4	25.1	25.8	26.5	27.2	24.6	24.6	24.7	30.0	26.0	26.7	-
105	TC	261	262	264	282	306	328	352	269	269	272	285	310	332	-
	SHC	261	262	254	219	173	135	97	269	269	259	232	182	140	-
	kW	26.8	26.8	26.9	27.5	28.3	29.0	29.8	27.0	27.0	27.1	27.6	28.4	29.1	-
115	TC	253	253	255	270	293	315	-	259	260	262	273	297	318	-
	SHC	253	253	245	214	168	131	-	259	260	247	227	177	136	-
	kW	29.3	29.3	29.6	30.1	30.9	31.7	-	29.7	29.6	29.8	30.2	31.1	31.8	-

**FORMULAS AND NOTES FOR USING EXPANDED PERFORMANCE DATA**

**LEGEND**

- BF - Bypass Factor
- Edb - Entering Dry-Bulb
- Ewb - Entering Wet-Bulb
- kW - Compressor Motor Power Input
- ldb - Leaving Dry-Bulb
- lwb - Leaving Wet-Bulb
- SHC - Sensible Heat capacity (1000 Btuh) Gross
- TC - Total Capacity (1000 Btuh) Gross

1. Direct interpolation is permissible. Do not extrapolate.
2. The following formulas may be used:
  - $t /ldb = t \text{ edb} - \text{sensible capacity (Btuh)} / (1.10 \times \text{cfm})$
  - $t /wb = \text{Wet bulb temp. corresponding to enthalpy of air leaving evaporator coil (h/wb)}$
  - $h /wb = h \text{ web} - \text{total capacity Btuh} / (4.5 \times \text{cfm})$   
where h ewb = Enthalpy of air entering evap. coil.

3. The SHC is based on 80 F edb temperature of air entering evaporator coil.  
Below 80 F edb, subtract (corr factor x cfm) from SHC.  
Above 80 F edb, add (corr factor x cfm) to SHC,

Bypass Factor (BF)	ENTERING AIR DRY-BULB TEMP (F)					
	79	78	77	76	75	under 75
	81	82	83	84	85	over 85
	Correction Factor					
0.05	1.04	2.07	3.11	4.14	5.18	Use Formula Below
0.10	0.98	1.96	2.94	3.92	4.91	
0.20	0.87	1.74	2.62	3.49	4.36	
0.30	0.76	1.53	2.29	3.05	3.82	
0.40	0.65	1.31	1.96	2.62	3.27	
0.50	0.55	1.09	1.64	2.18	2.73	
0.60	0.44	0.87	1.31	1.74	2.18	
0.70	0.33	0.65	0.98	1.31	1.64	

Interpolation is permissible.  
Correction factor =  $1.10 \times (1 - BF) \times (\text{edb} - 80)$ .

SCHEMATIC

ELECTRIC HEAT OPTION

ELECTRIC HEAT		
	208/240V AMPS	200/230V KW
A	71.3/82.3	25.7/34.2
B	117/135	42.2/56.1
C	156/180	56.2/74.8

1  
2  
3  
5  
6  
7  
9  
10  
13  
14  
20  
22  
24  
26  
30  
32

208/230-3-60  
220-3-50

FIELD  
POWER  
SUPPLY

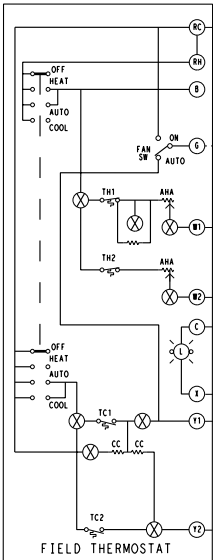
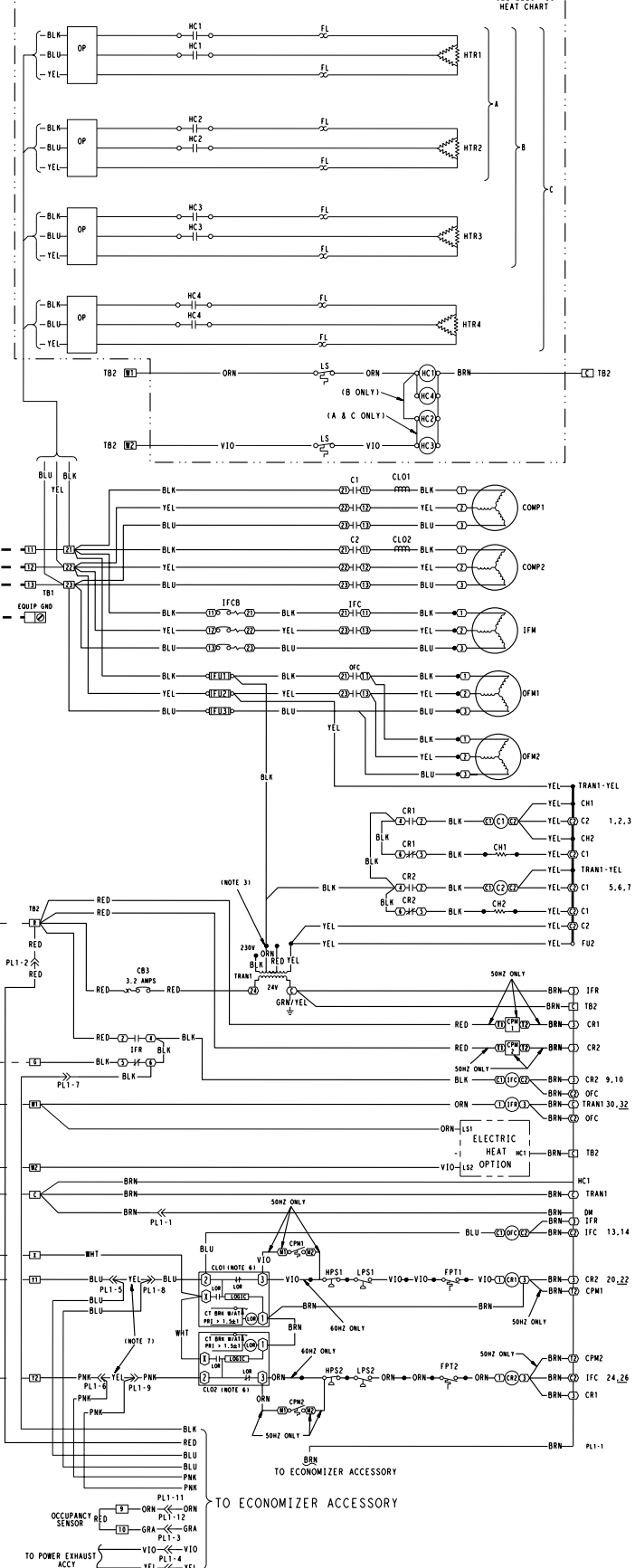

SHT 1 USED FOR REVISION RECORD		
PART NUMBER	REV	
208/230-3-60V PAS300H	50TJ501426 SHT 2 OF 3	2.0

# SCHEMATIC

ELECTRIC HEAT		
	480V AMPS	480V KW
A	39	32.4
B	66.1	55
C	96	79.8

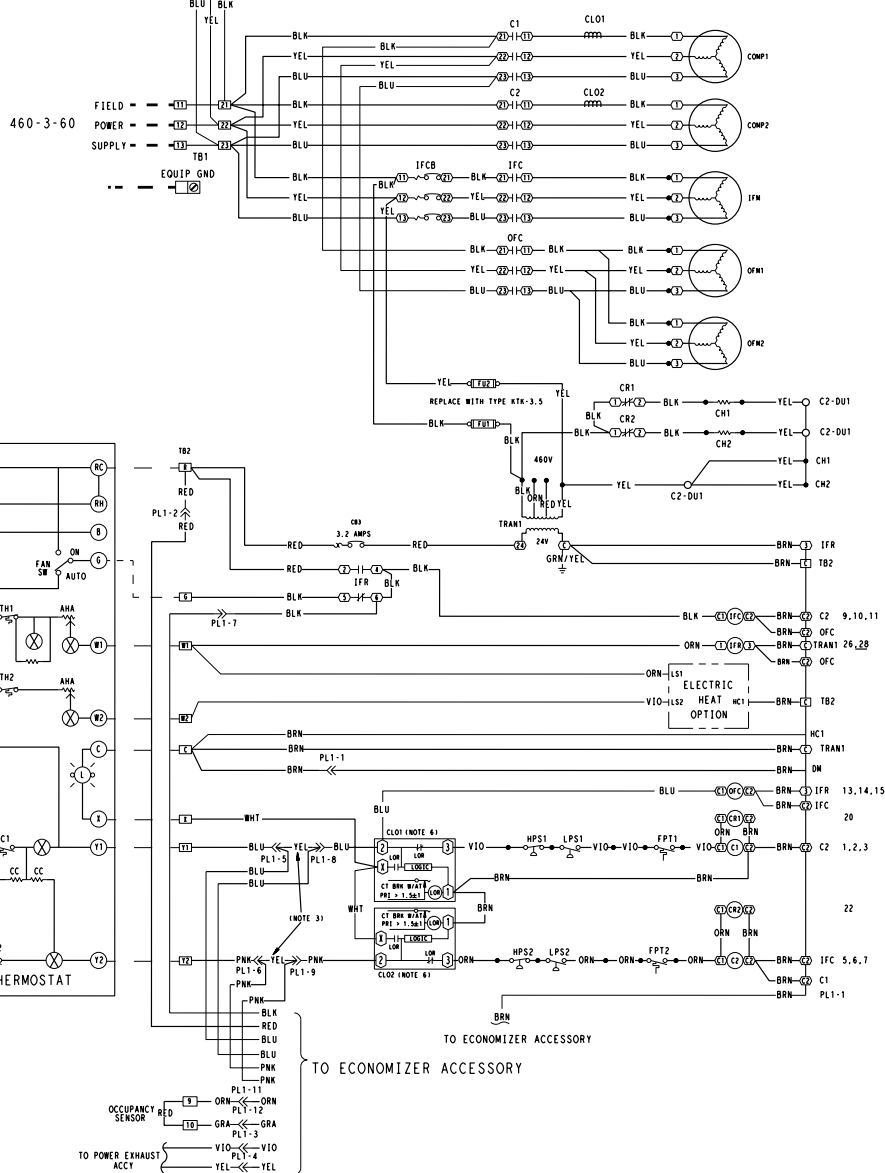
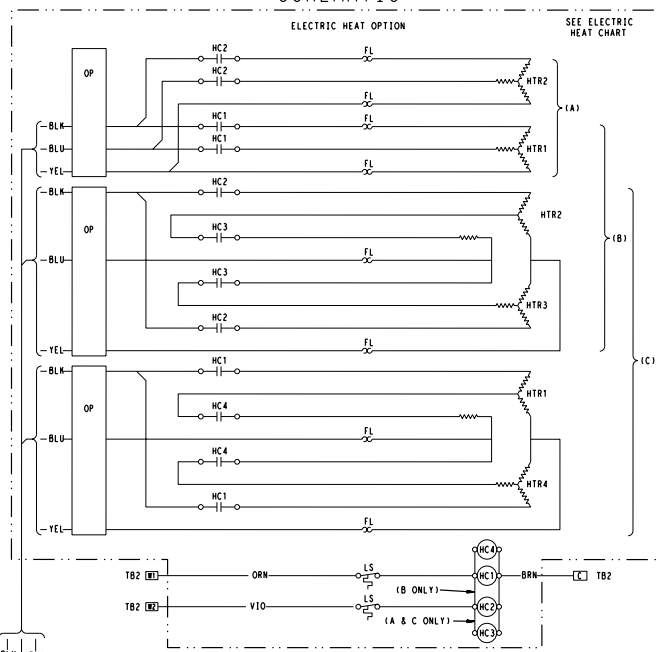

460 VOLT

SHT 1 USED FOR REVISION RECORD		
460V PAS300L	PART NUMBER 50TJ501427 SHT 2 OF 3	REV 2.0

SCHMATIC

575 VOLT

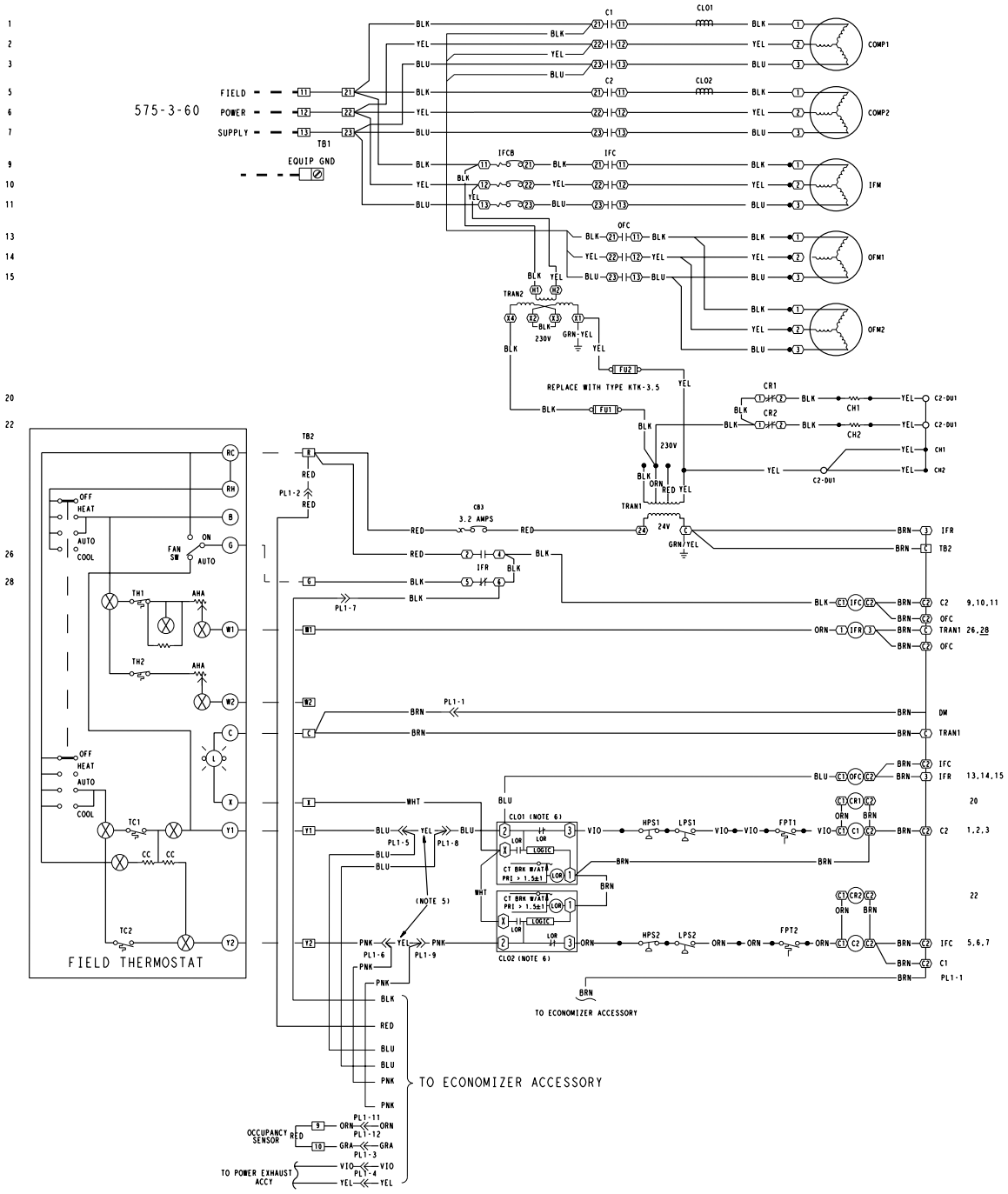

SHT 1 USED FOR REVISION RECORD		
PART NUMBER	REV	
575V PAS300S	50TJ501428 SHT 2 OF 3	2.0