

WIRING DIAGRAM MANUAL

Split System Heat Pump

N4H3 (F Series), N4H4 (F Series) R4H3, WCH3

Safety Labeling and Signal Words

DANGER, WARNING, CAUTION, and NOTE

The signal words **DANGER**, **WARNING**, **CAUTION**, and **NOTE** are used to identify levels of hazard seriousness. The signal word **DANGER** is only used on product labels to signify an immediate hazard. The signal words **WARNING**, **CAUTION**, and **NOTE** will be used on product labels and throughout this manual and other manuals that may apply to the product.

DANGER – Immediate hazards which **will** result in severe personal injury or death.

WARNING – Hazards or unsafe practices which **could** result in severe personal injury or death.

CAUTION – Hazards or unsafe practices which **may** result in minor personal injury or product or property damage.

NOTE – Used to highlight suggestions which **will** result in enhanced installation, reliability, or operation.

Signal Words in Manuals

The signal word **WARNING** is used throughout this manual in the following manner:



The signal word **CAUTION** is used throughout this manual in the following manner:



Signal Words on Product Labeling

Signal words are used in combination with colors and/or pictures on product labels.

TABLE OF CONTENTS

| | |
|--|---|
| 339701-101, 208-230v, 1 phase Wiring Diagram | 2 |
| 339697-101, 208-230v, 1 phase Wiring Diagram | 3 |
| 336751-101, 208-230v, 3 phase Wiring Diagram | 4 |
| 335877-101, 208-230v, 3 phase Wiring Diagram | 5 |
| 336752-101, 460v, 3 phase Wiring Diagram | 6 |
| 336878-101, 460v, 3 phase Wiring Diagram | 7 |

WARNING

DEATH, PERSONAL INJURY, AND/OR PROPERTY DAMAGE HAZARD

Failure to carefully read and follow this warning could result in equipment malfunction, property damage, personal injury and/or death.

Installation or repairs made by unqualified persons could result in equipment malfunction, property damage, personal injury and/or death.

The information contained in this manual is intended for use by a qualified service technician familiar with safety procedures and equipped with the proper tools and test instruments.

Installation must conform with local building codes and with the National Electrical Code NFPA70 current edition or Canadian Electrical Code Part 1 CSA C.22.1.

| Model Number | Wiring Diagram | Model Number | Wiring Diagram |
|--------------|----------------|--------------|----------------|
| N4H318*KF | 339701-101 | N4H418*KF | 339697-101 |
| N4H324*KF | 339701-101 | N4H424*KF | 339697-101 |
| N4H330*KF | 339701-101 | N4H430*KF | 339697-101 |
| N4H330GHF | 336751-101 | | |
| N4H336*KF | 339701-101 | N4H436*KF | 339697-101 |
| N4H336GHF | 336751-101 | | |
| N4H336GLF | 336752-101 | | |
| N4H342*KF | 339701-101 | N4H442*KF | 339697-101 |
| N4H342GHF | 336751-101 | | |
| N4H348*KF | 339701-101 | N4H448*KF | 339697-101 |
| N4H348GHF | 336751-101 | | |
| N4H348GLF | 336752-101 | | |
| N4H360*KF | 339697-101 | N4H460*KF | 339697-101 |
| N4H360GHF | 335877-101 | | |
| N4H360GLF | 335878-101 | | |

| Model Number | Wiring Diagram | Model Number | Wiring Diagram |
|--------------|----------------|--------------|----------------|
| R4H318*KB | 339701-101 | WCH3184GKB | 339701-101 |
| R4H319*KC | 339701-101 | WCH3194GKC | 339701-101 |
| R4H324*KB | 339701-101 | WCH3244GKB | 339701-101 |
| R4H325*KC | 339701-101 | WCH3254GKC | 339701-101 |
| R4H330*KB | 339701-101 | WCH3304GKB | 339701-101 |
| R4H331*KC | 339701-101 | WCH3314GKC | 339701-101 |
| R4H336*KC | 339701-101 | WCH3364GKC | 339701-101 |
| R4H337*KC | 339701-101 | WCH3374GKC | 339701-101 |
| R4H342*KC | 339701-101 | WCH3424GKC | 339701-101 |
| R4H343*KC | 339701-101 | WCH3434GKC | 339701-101 |
| R4H348*KC | 339701-101 | WCH3484GKC | 339701-101 |
| R4H349*KC | 339701-101 | WCH3494GKC | 339701-101 |
| R4H360*KC | 339697-101 | WCH3604GKC | 339697-101 |
| R4H361*KC | 339697-101 | WCH3614GKC | 339697-101 |

339701-101 USED ON MODELS: 208-230-1 PHASE

CONNECTION DIAGRAM

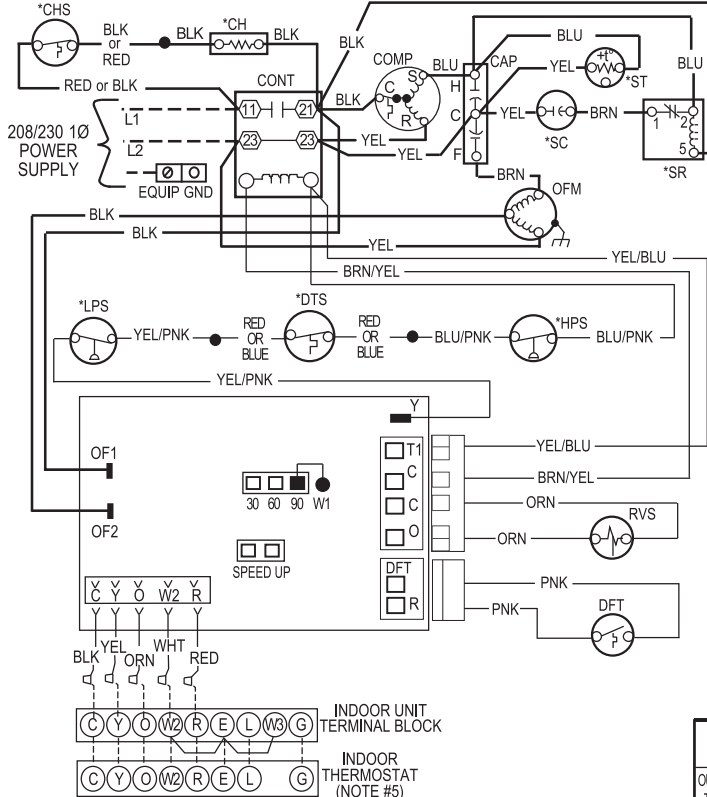

SCHEMATIC DIAGRAM (LADDER FORM)

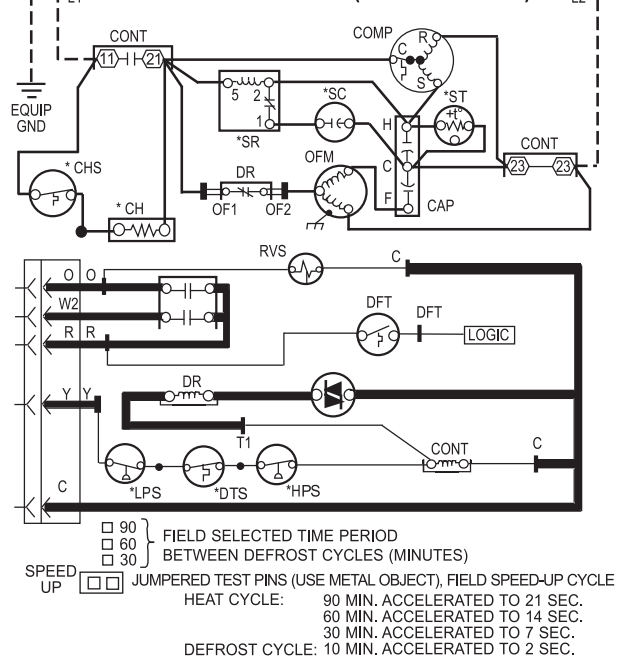

CONDENSING UNIT CHARGING INSTRUCTIONS
For use with units using R-410A refrigerant

-LEGEND-

- FACTORY POWER WIRING
- - - FIELD POWER WIRING
- FACTORY CONTROL WIRING
- - - - FIELD CONTROL WIRING
- ▬ CONDUCTOR ON CIRCUIT BOARD
- COMPONENT CONNECTION
- ▬ 1/4-IN QUICK CONNECT TERMINALS
- ⌞ FIELD SPLICE
- JUNCTION
- CAP CAPACITOR
- *CH CRANKCASE HEATER
- *CHS CRANKCASE HEATER SWITCH
- COMP COMPRESSOR
- CONT CONTACTOR
- CB CIRCUIT BOARD
- DFT DEFROST THERMOSTAT
- DR DEFROST RELAY & CIRCUITRY
- *DTS DISCHARGE TEMP. SWITCH
- *HPS HIGH PRESSURE SWITCH
- *LLS LIQUID LINE SOLENOID VALVE
- *LPS LOW PRESSURE SWITCH
- OFM OUTDOOR FAN MOTOR
- RVS REVERSING VALVE SOLENOID
- *SC START CAPACITOR
- *SR START RELAY
- *ST START THERMISTOR
- *MAY BE FACTORY OR FIELD INSTALLED

NOTES:

1. Compressor and fan motor furnished with inherent thermal protection.
2. To be wired in accordance with National Electric Code (N.E.C.) and local codes.
3. N.E.C. class 2, 24V circuit, min. 40 VA required, 60 VA on units installed with LLS.
4. Use copper conductors only, from disconnect to unit.
5. Must use thermostat and sub-base as stated in pre-sale literature.
6. If indoor section has a transformer with a grounded secondary, connect the grounded side to "C" on the circuit board.
7. If any of the original wire, as supplied, must be replaced, use the same or equivalent wire.
8. Check all electrical connections inside control box for tightness.
9. Do not attempt to operate unit until service valves have been opened.
10. Use conductors suitable for at least 75°C (167°F).

CAUTION

1. Compressor damage may occur if system is over charged.
2. This unit is factory charged with R-410A in accordance with the amount shown on the rating plate. The charge is adequate for most systems using matched coils and tubing not over 15 feet long. Check refrigerant charge for maximum efficiency. See Product Data Literature for required Indoor air Flow Rates and for use of line lengths over 15 feet.
3. Relieve pressure and recover all refrigerant before system repair or final disposal. Use all service ports and open all flow-control devices, including solenoid valves.
4. Never vent refrigerant to atmosphere. Use approved recovery equipment.

TABLE I - SUPERHEAT CHARGING TABLE
(SUPERHEAT °F AT LOW-SIDE SERVICE PORT)

| OUTDOOR TEMP °F | EVAPORATOR ENTERING AIR ° F WB. | | | | | | | | | | | | | | | |
|-----------------|---------------------------------|----|----|----|----|----|----|----|----|----|----|----|----|----|----|----|
| | 50 | 52 | 54 | 56 | 58 | 60 | 62 | 64 | 67 | 68 | 70 | 72 | 74 | 76 | 78 | 80 |
| 55 | 11 | 11 | 12 | 12 | 12 | 13 | 17 | 20 | 24 | 24 | 25 | 25 | 25 | 25 | 25 | 25 |
| 60 | 6 | 6 | 7 | 7 | 7 | 7 | 12 | 16 | 21 | 22 | 23 | 23 | 23 | 23 | 23 | 23 |
| 65 | -- | -- | -- | -- | -- | 3 | 7 | 12 | 18 | 19 | 21 | 21 | 22 | 22 | 22 | 22 |
| 70 | -- | -- | -- | -- | -- | -- | 7 | 14 | 16 | 18 | 20 | 20 | 20 | 20 | 20 | 20 |
| 75 | -- | -- | -- | -- | -- | -- | 3 | 11 | 13 | 16 | 18 | 18 | 18 | 18 | 18 | 18 |
| 82 | -- | -- | -- | -- | -- | -- | -- | 6 | 8 | 12 | 15 | 16 | 17 | 17 | 17 | 17 |
| 85 | -- | -- | -- | -- | -- | -- | -- | 4 | 7 | 11 | 14 | 15 | 16 | 16 | 16 | 16 |
| 90 | -- | -- | -- | -- | -- | -- | -- | 4 | 8 | 12 | 14 | 15 | 15 | 15 | 15 | 15 |
| 95 | -- | -- | -- | -- | -- | -- | -- | -- | 6 | 10 | 12 | 14 | 14 | 14 | 14 | 14 |
| 100 | -- | -- | -- | -- | -- | -- | -- | -- | 4 | 8 | 11 | 12 | 12 | 12 | 12 | 12 |
| 105 | -- | -- | -- | -- | -- | -- | -- | -- | 3 | 6 | 9 | 11 | 11 | 11 | 11 | 11 |
| 110 | -- | -- | -- | -- | -- | -- | -- | -- | 5 | 7 | 10 | 11 | 11 | 11 | 11 | 11 |
| 115 | -- | -- | -- | -- | -- | -- | -- | -- | 3 | 6 | 8 | 8 | 8 | 8 | 8 | 8 |

Where a dash (-) appears do not attempt to charge system under these conditions or refrigerant slugging may occur. Charge must be weighed in.
Note: Superheat °F is at low-side service port, allow a tolerance of +/- 3 °F
Note: Indoor dry bulb between 70 °F and 80 °F
* Optimum performance point, 82 °F outdoor ambient and (80 °F dry bulb), (67 °F wet bulb) indoor conditions. (DOE B Test Conditions)

TABLE II - REQUIRED SUCTION TUBE TEMPERATURE °F
(MEASURED AT LOW-SIDE SERVICE PORT)

| SUPERHEAT TEMP °F | SUCTION PRESSURE AT SERVICE PORT PSIG. | | | | | | | | | | | | | | | |
|-------------------|--|-----|-----|-----|-----|-----|-----|-----|-----|-----|-----|-----|-----|-----|-----|-----|
| | 108 | 112 | 117 | 121 | 126 | 131 | 139 | 141 | 146 | 151 | 156 | 161 | 166 | 171 | 176 | 181 |
| 0 | 35 | 37 | 39 | 41 | 43 | 45 | 47 | 49 | 51 | 53 | 55 | 57 | 59 | 61 | 63 | 65 |
| 2 | 37 | 39 | 41 | 43 | 45 | 47 | 49 | 51 | 53 | 55 | 57 | 59 | 61 | 63 | 65 | 67 |
| 4 | 39 | 41 | 43 | 45 | 47 | 49 | 51 | 53 | 55 | 57 | 59 | 61 | 63 | 65 | 67 | 69 |
| 6 | 41 | 43 | 45 | 47 | 49 | 51 | 53 | 55 | 57 | 59 | 61 | 63 | 65 | 67 | 69 | 71 |
| 8 | 43 | 45 | 47 | 49 | 51 | 53 | 55 | 57 | 59 | 61 | 63 | 65 | 67 | 69 | 71 | 73 |
| 10 | 45 | 47 | 49 | 51 | 53 | 55 | 57 | 59 | 61 | 63 | 65 | 67 | 69 | 71 | 73 | 75 |
| 12 | 47 | 49 | 51 | 53 | 55 | 57 | 59 | 61 | 63 | 65 | 67 | 69 | 71 | 73 | 75 | 77 |
| 14 | 49 | 51 | 53 | 55 | 57 | 59 | 61 | 63 | 65 | 67 | 69 | 71 | 73 | 75 | 77 | 79 |
| 16 | 51 | 53 | 55 | 57 | 59 | 61 | 63 | 65 | 67 | 69 | 71 | 73 | 75 | 77 | 79 | 81 |
| 18 | 53 | 55 | 57 | 59 | 61 | 63 | 65 | 67 | 69 | 71 | 73 | 75 | 77 | 79 | 81 | 83 |
| 20 | 55 | 57 | 59 | 61 | 63 | 65 | 67 | 69 | 71 | 73 | 75 | 77 | 79 | 81 | 83 | 85 |
| 22 | 57 | 59 | 61 | 63 | 65 | 67 | 69 | 71 | 73 | 75 | 77 | 79 | 81 | 83 | 85 | 87 |
| 24 | 59 | 61 | 63 | 65 | 67 | 69 | 71 | 73 | 75 | 77 | 79 | 81 | 83 | 85 | 87 | 89 |
| 26 | 61 | 63 | 65 | 67 | 69 | 71 | 73 | 75 | 77 | 79 | 81 | 83 | 85 | 87 | 89 | 91 |
| 28 | 63 | 65 | 67 | 69 | 71 | 73 | 75 | 77 | 79 | 81 | 83 | 85 | 87 | 89 | 91 | 93 |
| 30 | 65 | 67 | 69 | 71 | 73 | 75 | 77 | 79 | 81 | 83 | 85 | 87 | 89 | 91 | 93 | 95 |

COOLING ONLY CHARGING PROCEDURE

1. Operate unit a minimum of 10 minutes before checking charge.
2. Measure suction pressure by attaching an accurate gage to suction valve service port.
3. Measure suction temperature by attaching an accurate thermistor type or electronic thermometer to the suction line at service valve.
4. Measure outdoor air dry-bulb temperature with a thermometer.
5. Measure indoor air (entering indoor coil) wet-bulb temperature with a sling psychrometer.
6. Refer to Table I. Find outdoor temperature and evaporator entering air wet-bulb temperature. At this intersection, note superheat. Where a dash (-) appears on table do not attempt to charge system under these conditions or refrigerant slugging may occur. Charge must be weighed in, adding or removing 0.6 oz/lb of 3/8 liquid line above or below 15 ft, respectively.
7. Refer to Table II. Find superheat temperature located in step 6 and suction pressure. At this intersection note suction line temperature.
8. If unit has a higher suction line temperature than charted temperature, add refrigerant until charted temperature is reached.
9. If unit has a lower suction line temperature than charted temperature, remove and recover refrigerant until charted temperature is reached.
10. When adding refrigerant, charge in liquid form into the suction service port using a flow-restricting device.
11. If outdoor air temperature or pressure at suction valve changes, charge to new suction line temperature indicated on chart.
12. This procedure is valid when indoor air flow is within +/- 21% of its rated cfm



339701-101 REV. B

339701-101 REV. B



339697-101 USED ON MODELS: 208-230-1 PHASE

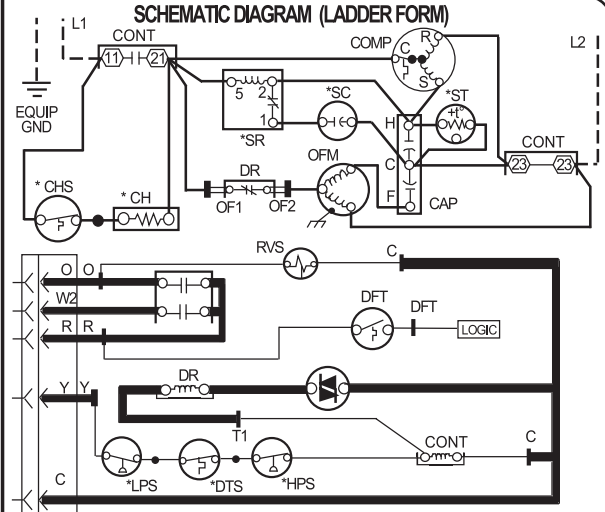
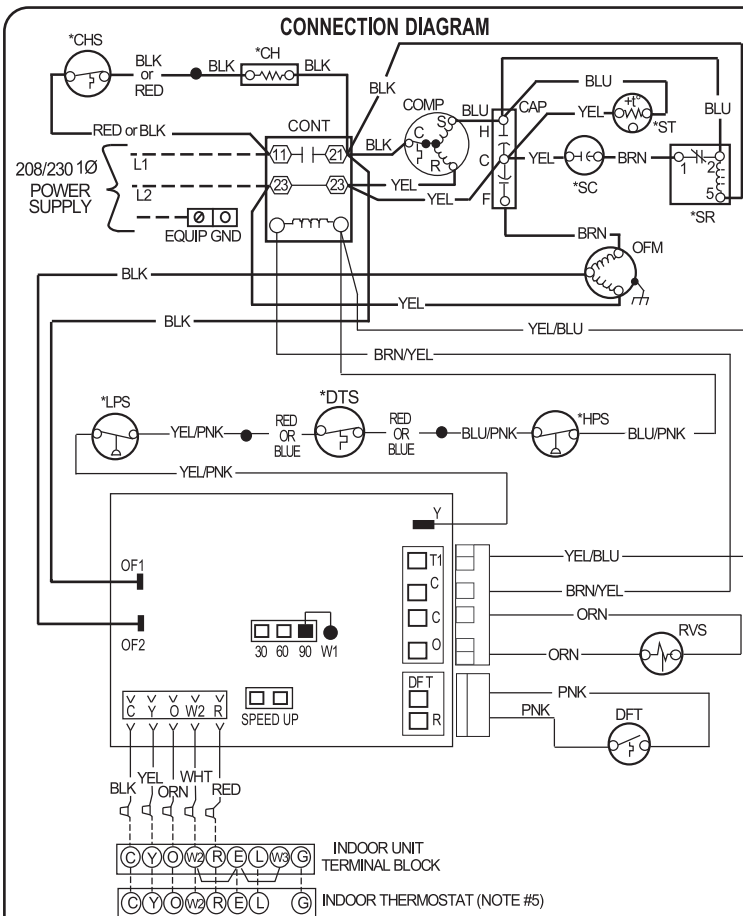

90
 60
 30
 BETWEEN DEFOST CYCLES (MINUTES)
 SPEED UP JUMPED TEST PINS (USE METAL OBJECT), FIELD SPEED-UP CYCLE
 HEAT CYCLE: 90 MIN. ACCELERATED TO 21 SEC.
 60 MIN. ACCELERATED TO 14 SEC.
 30 MIN. ACCELERATED TO 7 SEC.
 DEFOST CYCLE: 10 MIN. ACCELERATED TO 2 SEC.

CONDENSING UNIT CHARGING INSTRUCTIONS
For use with units using R-410A refrigerant

| Liquid Pressure at Service Valve (psig) | Required Subcooling Temperature (°F) | | | | | |
|---|--------------------------------------|-----|-----|-----|-----|-----|
| | 6 | 8 | 10 | 12 | 14 | 16 |
| 251 | 78 | 76 | 74 | 72 | 70 | 68 |
| 259 | 80 | 78 | 76 | 74 | 72 | 70 |
| 266 | 82 | 80 | 78 | 76 | 74 | 72 |
| 274 | 84 | 82 | 80 | 78 | 76 | 74 |
| 283 | 86 | 84 | 82 | 80 | 78 | 76 |
| 291 | 88 | 86 | 84 | 82 | 80 | 78 |
| 299 | 90 | 88 | 86 | 84 | 82 | 80 |
| 308 | 92 | 90 | 88 | 86 | 84 | 82 |
| 317 | 94 | 92 | 90 | 88 | 86 | 84 |
| 326 | 96 | 94 | 92 | 90 | 88 | 86 |
| 335 | 98 | 96 | 94 | 92 | 90 | 88 |
| 345 | 100 | 98 | 96 | 94 | 92 | 90 |
| 354 | 102 | 100 | 98 | 96 | 94 | 92 |
| 364 | 104 | 102 | 100 | 98 | 96 | 94 |
| 374 | 106 | 104 | 102 | 100 | 98 | 96 |
| 384 | 108 | 106 | 104 | 102 | 100 | 98 |
| 395 | 110 | 108 | 106 | 104 | 102 | 100 |
| 406 | 112 | 110 | 108 | 106 | 104 | 102 |
| 416 | 114 | 112 | 110 | 108 | 106 | 104 |
| 427 | 116 | 114 | 112 | 110 | 108 | 106 |
| 439 | 118 | 116 | 114 | 112 | 110 | 108 |
| 450 | 120 | 118 | 116 | 114 | 112 | 110 |
| 462 | 122 | 120 | 118 | 116 | 114 | 112 |
| 474 | 124 | 122 | 120 | 118 | 116 | 114 |

- COOLING ONLY CHARGING PROCEDURE**
- Only use sub cooling charging method when OD ambient is greater than 70°F and less than 100°F, indoor temp is greater than 70°F and less than 80°F, and line set is less than 80 ft.
 - Operate unit a minimum of 15 minutes before checking the charge.
 - Measure liquid service valve pressure by attaching an accurate gauge to the service port.
 - Measure the liquid line temperature by attaching an accurate thermometer type or electronic thermometer to the liquid line near the outdoor coil.
 - Refer to unit rating plate for required subcooling temperature.
 - Find the point where the required subcooling temperature intersects the measured liquid service valve pressure.
 - To obtain the required subcooling temperature at specific liquid line pressure, add refrigerant if liquid line temperature is higher than indicated. When adding refrigerant, charge in liquid form using a flow restricting device into suction service port. Recover refrigerant if temperature is lower. Allow a tolerance of +/- 3°F.

CAUTION

- Compressor damage may occur if system is over charged.
- This unit is factory charged with R-410A in accordance with the amount shown on the rating plate. The charge is adequate for most systems using matched coils and tubing not over 15 feet long. Check refrigerant charge for maximum efficiency. See Product Data Literature for required Indoor air Flow Rates and for use of line lengths over 15 feet.
- Relieve pressure and recover all refrigerant before system repair or final disposal. Use all service ports and open all flow-control devices, including solenoid valves.
- Never vent refrigerant to atmosphere. Use approved recovery equipment.



339697-101 REV. B

LEGEND

- FACTORY POWER WIRING
- FACTORY CONTROL WIRING
- FIELD CONTROL WIRING
- - - - - FIELD POWER WIRING
- CONDUCTOR ON CIRCUIT BOARD
- COMPONENT CONNECTION
- 1/4-IN QUICK CONNECT TERMINAL
- FIELD SPLICE
- JUNCTION
- PLUG RECEPTACLE
- CB CIRCUIT BOARD
- CAP CAPACITOR (CUAL RUN)
- *CH CRANKCASE HEATER
- *CHS CRANKCASE HEATER SWITCH
- COMP COMPRESSOR
- CONT CONTACTOR
- DFT DEFOST THERMOSTAT
- DR DEFOST RELAY AND CIRCUITRY
- *DTS DISCHARGE TEMP SWITCH
- *HPS HIGH PRESSURE SWITCH
- *LPS LOW PRESSURE SWITCH
- OFM OUTDOOR FAN MOTOR
- RVS REVERSING VALVE SOLENOID
- *SC START CAPACITOR
- *SR START RELAY
- *ST START THERMISTOR

* MAY BE FACTORY OR FIELD INSTALLED

NOTES:

- Symbols are electrical representation only.
- Compressor and fan motor furnished with inherent thermal protection.
- To be wired in accordance with National Electric N.E.C. and local codes.
- N.E.C. class 2, 24 V circuit, min. 40 VA required, 60 VA on units installed with LLS.
- Use copper conductors only. Use conductors suitable for at least 75°C (167°F).
- Must use thermostat and sub-base as stated in pre-sale literature.
- If indoor section has a transformer with a grounded secondary, connect the grounded side to "C" on the circuit board.
- If any of the original wire, as supplied, must be replaced, use the same or equivalent wire.
- Check all electrical connections inside control box for tightness.
- Do not attempt to operate unit until service valves have been opened.
- Use conductors suitable for at least 75°C (167°F).



339697-101 REV. B

336751-101 USED ON MODELS: 208-230-3 PHASE

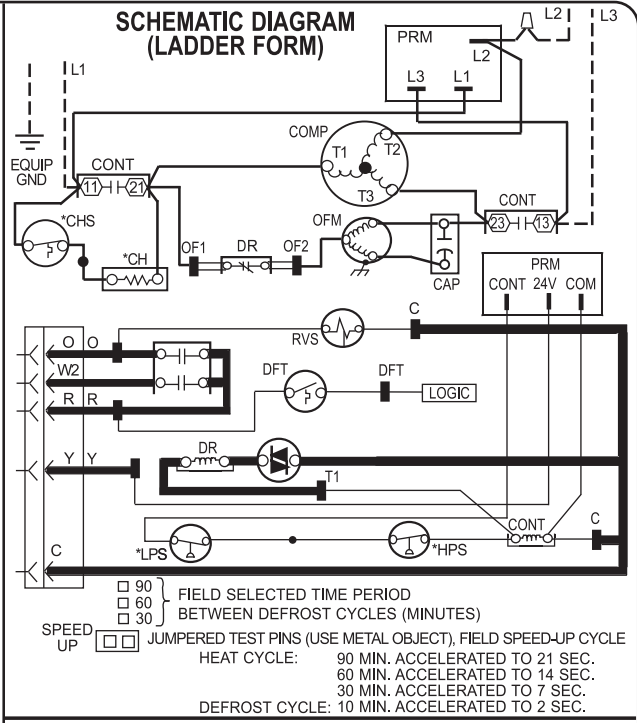
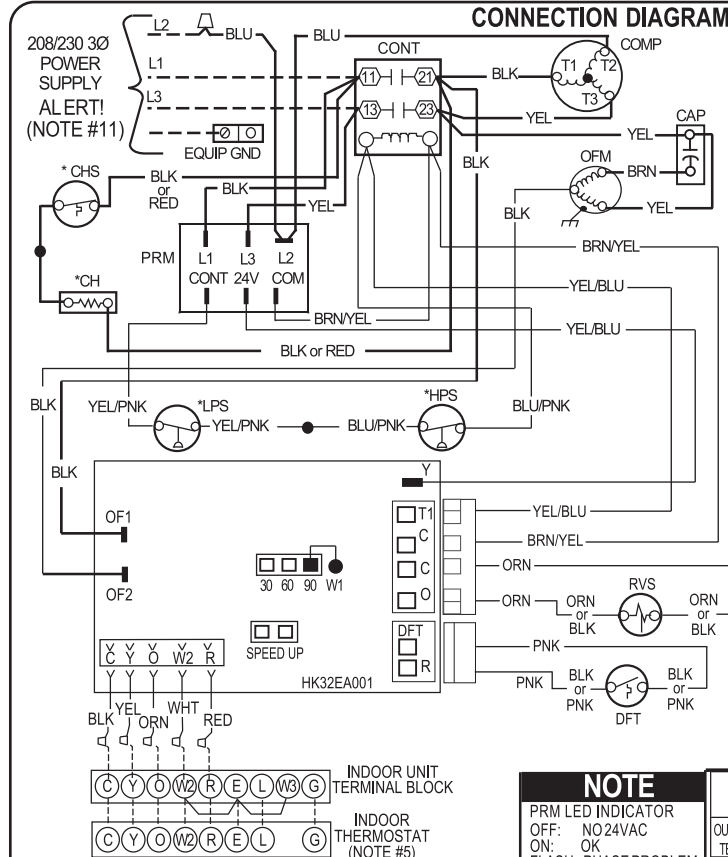

CONDENSING UNIT CHARGING INSTRUCTIONS
For use with units using R-410A refrigerant

NOTE

PRM LED INDICATOR
OFF: NO 24VAC
ON: OK
FLASH: PHASE PROBLEM

NOTES:

- Compressor and fan motor furnished with inherent thermal protection.
- To be wired in accordance with National Electric Code (N.E.C.), and local codes.
- N.E.C. class 2, 24V circuit, min. 40 VA required.
- Use copper conductors only, from disconnect to unit.
- Must use thermostat and sub-base as stated in pre-sale literature.
- If indoor section has a transformer with a grounded secondary, connect the grounded side to "C" on the circuit board.
- If any of the original wire, as supplied, must be replaced, use the same or equivalent wire.
- Check all electrical connections inside control box for tightness.
- Do not attempt to operate unit until service valves have been opened.
- It is imperative to connect 3Ø field power to unit with correct phasing. The Phase Rotation Monitor will not allow the contactor to be energized if the phasing is not correct. If phasing is reversed, simply interchange any two of the three power connections on the field side.
- Use conductors suitable for at least 75°C (167°F).

CAUTION

- Compressor damage may occur if system is over charged.
- This unit is factory charged with R-410A in accordance with the amount shown on the rating plate. The charge is adequate for most systems using matched coils and tubing not over 15 feet long. Check refrigerant charge for maximum efficiency. See Product Data Literature for required Indoor Air Flow Rates and for use of line lengths over 15 feet.
- Relieve pressure and recover all refrigerant before system repair or final disposal. Use all service ports and open all flow-control devices, including solenoid valves.
- Never vent refrigerant to atmosphere. Use approved recovery equipment.

TABLE I - SUPERHEAT CHARGING TABLE (SUPERHEAT °F AT LOW-SIDE SERVICE PORT)

| OUTDOOR TEMP. °F | EVAPORATOR ENTERING AIR °F WB. | | | | | | | | | | | | | |
|------------------|--------------------------------|----|----|----|----|----|----|----|----|----|----|----|----|----|
| | 50 | 52 | 54 | 56 | 58 | 60 | 62 | 64 | 67 | 68 | 70 | 72 | 74 | 76 |
| 55 | 11 | 11 | 12 | 12 | 12 | 13 | 17 | 20 | 24 | 24 | 25 | 25 | 25 | 25 |
| 60 | 6 | 6 | 7 | 7 | 7 | 7 | 12 | 16 | 21 | 22 | 23 | 23 | 23 | 23 |
| 65 | -- | -- | -- | -- | -- | 3 | 7 | 12 | 18 | 19 | 21 | 21 | 22 | 22 |
| 70 | -- | -- | -- | -- | -- | -- | 7 | 14 | 16 | 18 | 20 | 20 | 20 | 20 |
| 75 | -- | -- | -- | -- | -- | -- | -- | 3 | 11 | 13 | 16 | 18 | 18 | 19 |
| 82 | -- | -- | -- | -- | -- | -- | -- | *6 | 8 | 12 | 15 | 16 | 17 | 17 |
| 85 | -- | -- | -- | -- | -- | -- | -- | 4 | 7 | 11 | 14 | 15 | 16 | 16 |
| 90 | -- | -- | -- | -- | -- | -- | -- | -- | 4 | 8 | 12 | 14 | 15 | 15 |
| 95 | -- | -- | -- | -- | -- | -- | -- | -- | -- | 6 | 10 | 12 | 14 | 14 |
| 100 | -- | -- | -- | -- | -- | -- | -- | -- | -- | 4 | 8 | 11 | 12 | 12 |
| 105 | -- | -- | -- | -- | -- | -- | -- | -- | -- | 3 | 6 | 9 | 11 | 11 |
| 110 | -- | -- | -- | -- | -- | -- | -- | -- | -- | -- | 5 | 7 | 10 | 10 |
| 115 | -- | -- | -- | -- | -- | -- | -- | -- | -- | -- | 3 | 6 | 8 | 8 |

Where a dash (-) appears do not attempt to charge system under these conditions or refrigerant slugging may occur. Charge must be weighed in. Note: Superheat °F is at low-side service port, allow a tolerance of +/- 3 °F. Note: Indoor dry bulb between 70 °F and 80 °F. * Optimum performance point, 82 °F outdoor ambient and (80 °F dry bulb), (67 °F wet bulb) indoor conditions. (DOE B Test Conditions)

TABLE II - REQUIRED SUCTION TUBE TEMPERATURE °F (MEASURED AT LOW-SIDE SERVICE PORT)

| SUPERHEAT TEMP. °F | SUCTION PRESSURE AT SERVICE PORT PSIG. | | | | | | | | |
|--------------------|--|-----|-----|-----|-----|-----|-----|-----|-----|
| | 108 | 112 | 117 | 121 | 126 | 131 | 139 | 141 | 146 |
| 0 | 35 | 37 | 39 | 41 | 43 | 45 | 47 | 49 | 51 |
| 2 | 37 | 39 | 41 | 43 | 45 | 47 | 49 | 51 | 53 |
| 4 | 39 | 41 | 43 | 45 | 47 | 49 | 51 | 53 | 55 |
| 6 | 41 | 43 | 45 | 47 | 49 | 51 | 53 | 55 | 57 |
| 8 | 43 | 45 | 47 | 49 | 51 | 53 | 55 | 57 | 59 |
| 10 | 45 | 47 | 49 | 51 | 53 | 55 | 57 | 59 | 61 |
| 12 | 47 | 49 | 51 | 53 | 55 | 57 | 59 | 61 | 63 |
| 14 | 49 | 51 | 53 | 55 | 57 | 59 | 61 | 63 | 65 |
| 16 | 51 | 53 | 55 | 57 | 59 | 61 | 63 | 65 | 67 |
| 18 | 53 | 55 | 57 | 59 | 61 | 63 | 65 | 67 | 69 |
| 20 | 55 | 57 | 59 | 61 | 63 | 65 | 67 | 69 | 71 |
| 22 | 57 | 59 | 61 | 63 | 65 | 67 | 69 | 71 | 73 |
| 24 | 59 | 61 | 63 | 65 | 67 | 69 | 71 | 73 | 75 |
| 26 | 61 | 63 | 65 | 67 | 69 | 71 | 73 | 75 | 77 |
| 28 | 63 | 65 | 67 | 69 | 71 | 73 | 75 | 77 | 79 |
| 30 | 65 | 67 | 69 | 71 | 73 | 75 | 77 | 79 | 81 |

-LEGEND-

- FACTORY POWER WIRING
 - - - FIELD POWER WIRING
 - FACTORY CONTROL WIRING
 - - - FIELD CONTROL WIRING
 - CONDUCTOR ON CIRCUIT BOARD
 - COMPONENT CONNECTION
 - 1/4-IN QUICK CONNECT TERMINALS
 - ⌞ FIELD SPLICE
 - JUNCTION
 - CAP CAPACITOR
 - *CH CRANKCASE HEATER
 - *CHS CRANKCASE HEATER SWITCH
 - COMP COMPRESSOR
 - CONT CONTACTOR
 - CB CIRCUIT BOARD
 - DFT DEFROST THERMOSTAT
 - DR DEFROST RELAY & CIRCUITRY
 - *HPS HIGH PRESSURE SWITCH
 - *LPS LOW PRESSURE SWITCH
 - OFM OUTDOOR FAN MOTOR
 - PRM PHASE ROTATION
 - RVS REVERSING VALVE SOLENOID
- *MAY BE FACTORY OR FIELD INSTALLED

COOLING ONLY CHARGING PROCEDURE

- Operate unit a minimum of 10 minutes before checking charge.
- Measure suction pressure by attaching an accurate gage to suction valve service port.
- Measure suction temperature by attaching an accurate thermistor type or electronic thermometer to the suction line at service valve.
- Measure outdoor air dry-bulb temperature with a thermometer.
- Measure indoor air (entering indoor coil) wet-bulb temperature with a sling psychrometer.
- Refer to Table I. Find outdoor temperature and evaporator entering air wet-bulb temperature. At this intersection, note superheat. Where a dash (-) appears on table do not attempt to charge system under these conditions or refrigerant slugging may occur. Charge must be weighed in, adding or removing 0.6 oz/ft of 3/8 liquid line above or below 15 ft. respectively.
- Refer to Table II. Find superheat temperature located in step 6 and suction pressure. At this intersection note suction line temperature.
- If unit has a higher suction line temperature than charted temperature, add refrigerant until charted temperature is reached.
- If unit has a lower suction line temperature than charted temperature, remove and recover refrigerant until charted temperature is reached.
- When adding refrigerant, charge in liquid form into the suction service port using a flow-restricting device.
- If outdoor air temperature or pressure at suction valve changes, charge to new suction line temperature indicated on chart.
- This procedure is valid when indoor air flow is within +/- 21% of its rated cfm



336751-101 REV. B

335877-101 USED ON MODELS: 5 TON, 208-230-3 PHASE

CONNECTION DIAGRAM

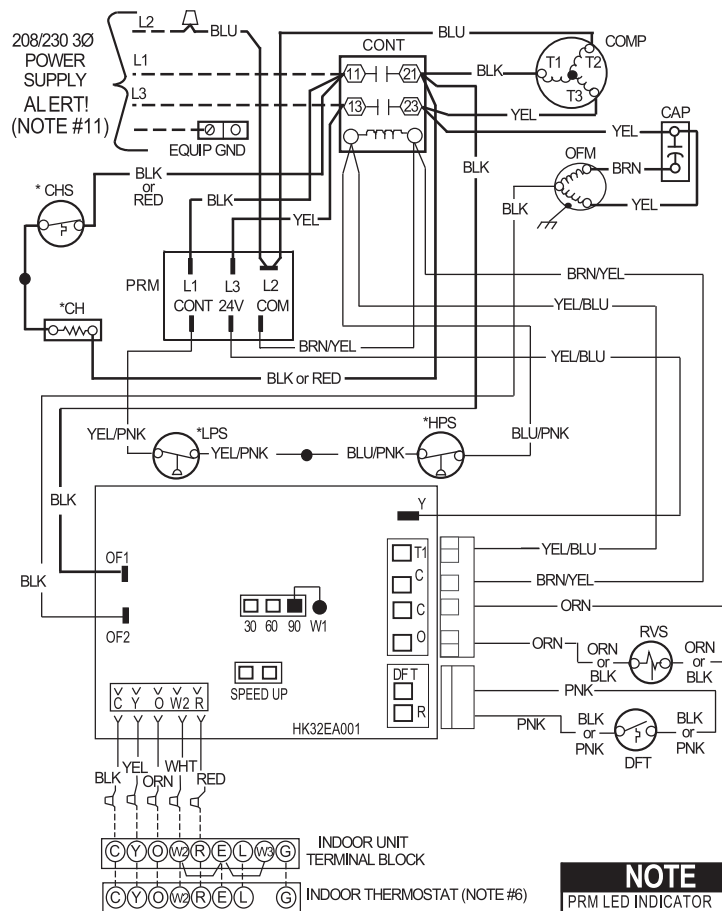

NOTE

PRM LED INDICATOR
 OFF: NO 24VAC
 ON: OK
 FLASH: PHASE PROBLEM

LEGEND

- FACTORY POWER WIRING
 - FACTORY CONTROL WIRING
 - FIELD CONTROL WIRING
 - - - - - FIELD POWER WIRING
 - CONDUCTOR ON CIRCUIT BOARD
 - COMPONENT CONNECTION
 - 1/4-INCH QUICK CONNECT
 - ⌒ FIELD SPLICE
 - JUNCTION
- CAP CAPACITOR
 - *CH CRANKCASE HEATER
 - *CHS CRANKCASE HEATER SWITCH
 - COMP COMPRESSOR
 - CONT CONTACTOR
 - CB CIRCUIT BOARD
 - DFT DEFROST THERMOSTAT
 - DR DEFROST RELAY AND CIRCUITRY
 - *HPS HIGH PRESSURE SWITCH
 - *LPS LOW PRESSURE SWITCH
 - OFM OUTDOOR FAN MOTOR
 - PRM PHASE ROTATION MONITOR
 - RVS REVERSING VALVE SOLENOID

* MAY BE FACTORY OR FIELD INSTALLED

NOTES:

1. Symbols are electrical representation only.
2. Compressor and fan motor furnished with inherent thermal protection.
3. To be wired in accordance with National Electric N.E.C. and local codes.
4. N.E.C. class 2, 24 V circuit, min. 40 VA required.
5. Use copper conductors only, from disconnect to unit.
6. Must use thermostat and sub-base as stated in pre-sale literature.
7. If indoor section has a transformer with a grounded secondary, connect the grounded side to "C" on the circuit board.
8. If any of the original wire, as supplied, must be replaced, use the same or equivalent wire.
9. Check all electrical connections inside control box for tightness.
10. Do not attempt to operate unit until service valves have been opened.
11. It is imperative to connect 3Ø field power to unit with correct phasing. The Phase Rotation Monitor will not allow the contactor to be energized if the phasing is not correct. If phasing is reversed, simply interchange any two of the three power connections on the field side.
12. Use conductors suitable for at least 75°C (167°F).

SCHEMATIC DIAGRAM (LADDER FORM)

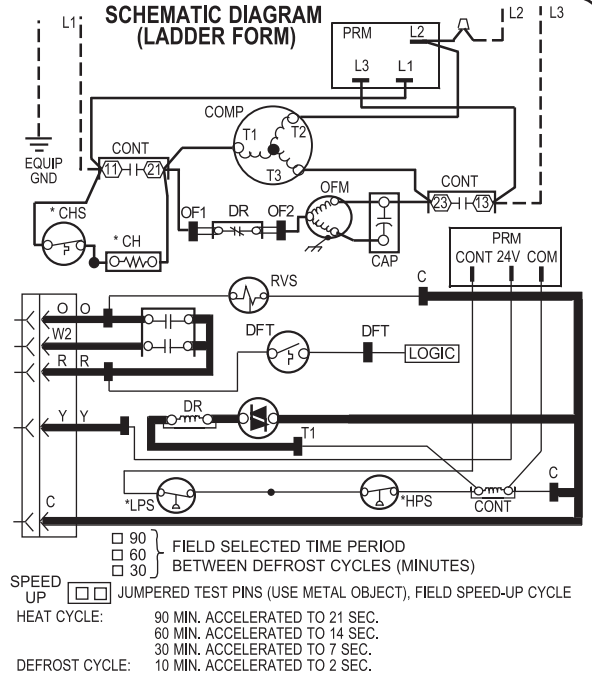

- 90 FIELD SELECTED TIME PERIOD BETWEEN DEFROST CYCLES (MINUTES)
- 60
- 30
- SPEED UP JUMPERED TEST PINS (USE METAL OBJECT), FIELD SPEED-UP CYCLE
- HEAT CYCLE: 90 MIN. ACCELERATED TO 21 SEC.
60 MIN. ACCELERATED TO 14 SEC.
30 MIN. ACCELERATED TO 7 SEC.
- DEFROST CYCLE: 10 MIN. ACCELERATED TO 2 SEC.

CONDENSING UNIT CHARGING INSTRUCTIONS
 For use with units using R-410A refrigerant

REQUIRED LIQUID LINE TEMPERATURE

| Liquid Pressure at Service Valve (psig) | Required Subcooling Temperature (°F) | | | | | |
|---|--------------------------------------|-----|-----|-----|-----|-----|
| | 6 | 8 | 10 | 12 | 14 | 16 |
| 251 | 78 | 76 | 74 | 72 | 70 | 68 |
| 259 | 80 | 78 | 76 | 74 | 72 | 70 |
| 266 | 82 | 80 | 78 | 76 | 74 | 72 |
| 274 | 84 | 82 | 80 | 78 | 76 | 74 |
| 283 | 86 | 84 | 82 | 80 | 78 | 76 |
| 291 | 88 | 86 | 84 | 82 | 80 | 78 |
| 299 | 90 | 88 | 86 | 84 | 82 | 80 |
| 308 | 92 | 90 | 88 | 86 | 84 | 82 |
| 317 | 94 | 92 | 90 | 88 | 86 | 84 |
| 326 | 96 | 94 | 92 | 90 | 88 | 86 |
| 335 | 98 | 96 | 94 | 92 | 90 | 88 |
| 345 | 100 | 98 | 96 | 94 | 92 | 90 |
| 354 | 102 | 100 | 98 | 96 | 94 | 92 |
| 364 | 104 | 102 | 100 | 98 | 96 | 94 |
| 374 | 106 | 104 | 102 | 100 | 98 | 96 |
| 384 | 108 | 106 | 104 | 102 | 100 | 98 |
| 395 | 110 | 108 | 106 | 104 | 102 | 100 |
| 406 | 112 | 110 | 108 | 106 | 104 | 102 |
| 416 | 114 | 112 | 110 | 108 | 106 | 104 |
| 427 | 116 | 114 | 112 | 110 | 108 | 106 |
| 439 | 118 | 116 | 114 | 112 | 110 | 108 |
| 450 | 120 | 118 | 116 | 114 | 112 | 110 |
| 462 | 122 | 120 | 118 | 116 | 114 | 112 |
| 474 | 124 | 122 | 120 | 118 | 116 | 114 |

COOLING ONLY CHARGING PROCEDURE

1. Only use subcooling charging method when OD ambient is greater than 70°F and less than 100°F, indoor temp is greater than 70°F and less than 80°F, and line set is less than 80 ft.
2. Operate unit a minimum of 15 minutes before checking the charge.
3. Measure liquid service valve pressure by attaching an accurate gauge to the service port.
4. Measure the liquid line temperature by attaching an accurate thermistor type or electronic thermometer to the liquid line near the outdoor coil.
5. Refer to unit rating plate for required subcooling temperature.
6. Find the point where the required subcooling temperature intersects the measured liquid service valve pressure.
7. To obtain the required subcooling temperature at specific liquid line pressure, add refrigerant if liquid line temperature is higher than indicated. When adding refrigerant, charge in liquid form using a flow restricting device into suction service port. Recover refrigerant if temperature is lower. Allow a tolerance of +/- 3°F.

CAUTION

1. Compressor damage may occur if system is over charged.
2. This unit is factory charged with R-410A in accordance with the amount shown on the rating plate. The charge is adequate for most systems using matched coils and tubing not over 15 feet long. Check refrigerant charge for maximum efficiency. See Product Data Literature for required Indoor air Flow Rates and for use of line lengths over 15 feet.
3. Relieve pressure and recover all refrigerant before system repair or final disposal. Use all service ports and open all flow-control devices, including solenoid valves.
4. Never vent refrigerant to atmosphere. Use approved recovery equipment.



335877-101 REV. B

336752-101 USED ON MODELS: 460-3 PHASE

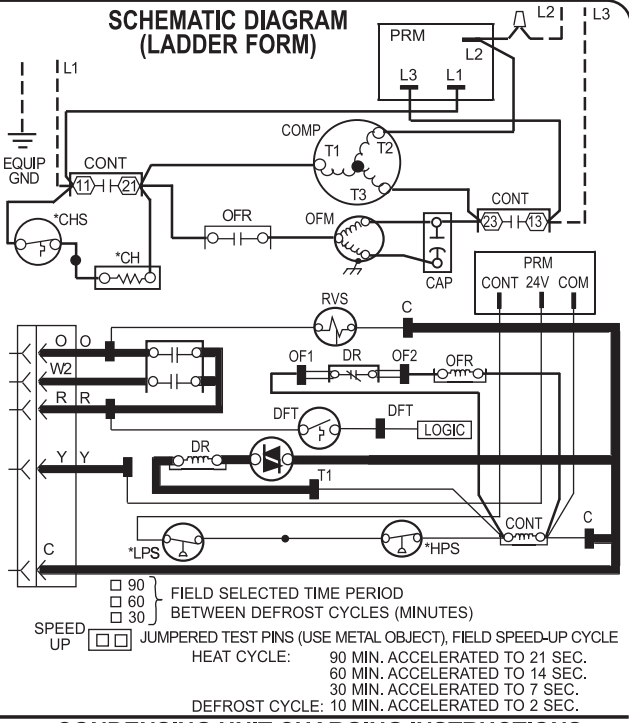
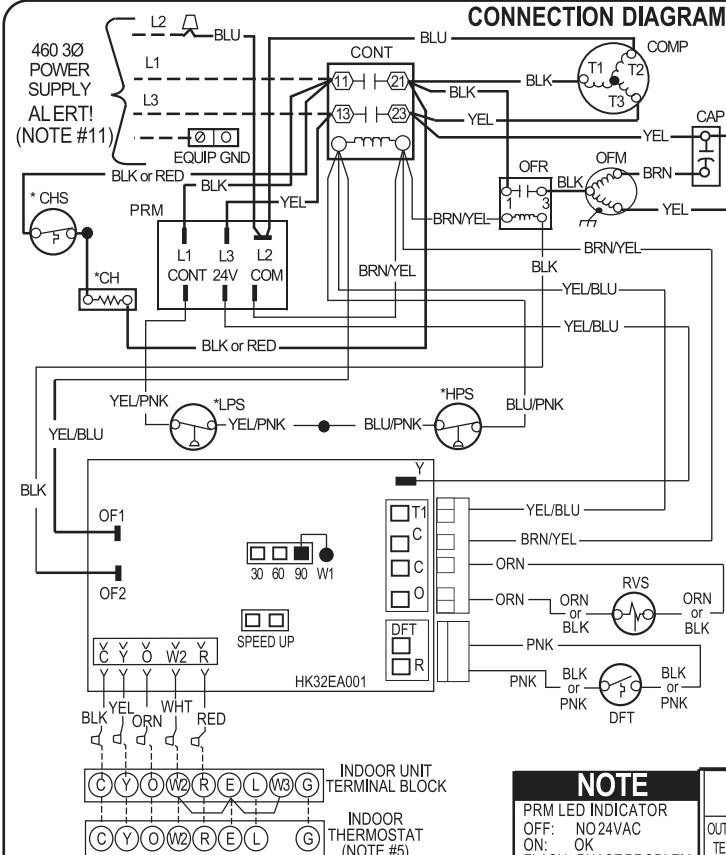

CONDENSING UNIT CHARGING INSTRUCTIONS
For use with units using R-410A refrigerant

-LEGEND-

- FACTORY POWER WIRING
- - - FIELD POWER WIRING
- FACTORY CONTROL WIRING
- - - FIELD CONTROL WIRING
- CONDUCTOR ON CIRCUIT BOARD
- COMPONENT CONNECTION
- 1/4-IN QUICK CONNECT TERMINALS
- ⌒ FIELD SPLICE
- JUNCTION
- CAP CAPACITOR
- *CH CRANKCASE HEATER
- *CHS CRANKCASE HEATER SWITCH
- COMP COMPRESSOR
- CONT CONTACTOR
- CB CIRCUIT BOARD
- DFT DEFROST THERMOSTAT
- DR DEFROST RELAY & CIRCUITRY
- *HPS HIGH PRESSURE SWITCH
- *LPS LOW PRESSURE SWITCH
- OFM OUTDOOR FAN MOTOR
- OFR OUTDOOR FAN RELAY
- PRM PHASE ROTATION MONITOR
- RVS REVERSING VALVE SOLENOID

*MAY BE FACTORY OR FIELD INSTALLED

NOTES:

1. Compressor and fan motor furnished with inherent thermal protection.
2. To be wired in accordance with National Electric Code (N.E.C.) and local codes.
3. N.E.C. class 2, 24V circuit, min. 40 VA required.
4. Use copper conductors only, from disconnect to unit.
5. Must use thermostat and sub-base as stated in pre-sale literature.
6. If indoor section has a transformer with a grounded secondary, connect the grounded side to "C" on the circuit board.
7. If any of the original wire, as supplied, must be replaced, use the same or equivalent wire.
8. Check all electrical connections inside control box for tightness.
9. Do not attempt to operate unit until service valves have been opened.
10. It is imperative to connect 3Ø field power to unit with correct phasing. The Phase Rotation Monitor will not allow the contactor to be energized if the phasing is not correct. If phasing is reversed, simply interchange any two of the three power connections on the field side.
11. Use conductors suitable for at least 75°C (167°F).

CAUTION

1. Compressor damage may occur if system is over charged.
2. This unit is factory charged with R-410A in accordance with the amount shown on the rating plate. The charge is adequate for most systems using matched coils and tubing not over 15 feet long. Check refrigerant charge for maximum efficiency. See Product Data Literature for required Indoor Air Flow Rates and for use of line lengths over 15 feet.
3. Relieve pressure and recover all refrigerant before system repair or final disposal. Use all service ports and open all flow-control devices, including solenoid valves.
4. Never vent refrigerant to atmosphere. Use approved recovery equipment.

NOTE
PRM LED INDICATOR
OFF: NO 24VAC
ON: OK
FLASH: PHASE PROBLEM

TABLE I - SUPERHEAT CHARGING TABLE (SUPERHEAT °F AT LOW-SIDE SERVICE PORT)

| OUTDOOR TEMP °F | EVAPORATOR ENTERING AIR °F WB. | | | | | | | | | | | | | | | |
|-----------------|--------------------------------|----|----|----|----|----|----|----|----|----|----|----|----|----|----|--|
| | 50 | 52 | 54 | 56 | 58 | 60 | 62 | 64 | 67 | 68 | 70 | 72 | 74 | 76 | 78 | |
| 55 | 11 | 11 | 12 | 12 | 12 | 13 | 17 | 20 | 24 | 24 | 25 | 25 | 25 | 25 | 25 | |
| 60 | 6 | 6 | 7 | 7 | 7 | 7 | 12 | 16 | 21 | 22 | 23 | 23 | 23 | 23 | 23 | |
| 65 | -- | -- | -- | -- | -- | 3 | 7 | 12 | 18 | 19 | 21 | 21 | 22 | 22 | 22 | |
| 70 | -- | -- | -- | -- | -- | -- | 7 | 14 | 16 | 18 | 20 | 20 | 20 | 20 | 20 | |
| 75 | -- | -- | -- | -- | -- | -- | 3 | 11 | 13 | 16 | 18 | 18 | 18 | 18 | 18 | |
| 82 | -- | -- | -- | -- | -- | -- | -- | 6 | 8 | 12 | 15 | 16 | 17 | 17 | 17 | |
| 85 | -- | -- | -- | -- | -- | -- | -- | 4 | 7 | 11 | 14 | 15 | 16 | 16 | 16 | |
| 90 | -- | -- | -- | -- | -- | -- | -- | 4 | 8 | 12 | 14 | 15 | 15 | 15 | 15 | |
| 95 | -- | -- | -- | -- | -- | -- | -- | -- | 6 | 10 | 12 | 14 | 14 | 14 | 14 | |
| 100 | -- | -- | -- | -- | -- | -- | -- | -- | 4 | 8 | 11 | 11 | 12 | 12 | 12 | |
| 105 | -- | -- | -- | -- | -- | -- | -- | -- | 3 | 6 | 9 | 11 | 11 | 11 | 11 | |
| 110 | -- | -- | -- | -- | -- | -- | -- | -- | -- | 5 | 7 | 10 | 10 | 10 | 10 | |
| 115 | -- | -- | -- | -- | -- | -- | -- | -- | -- | 3 | 6 | 8 | 8 | 8 | 8 | |

Where a dash (-) appears do not attempt to charge system under these conditions or refrigerant slugging may occur. Charge must be weighed in. Note: Superheat °F is at low-side service port, allow a tolerance of +/- 3 °F. Note: Indoor dry bulb between 70 °F and 80 °F. * Optimum performance point, 82 °F outdoor ambient and (80 °F dry bulb), (67 °F wet bulb) indoor conditions. (DOE B Test Conditions)

TABLE II - REQUIRED SUCTION TUBE TEMPERATURE °F (MEASURED AT LOW-SIDE SERVICE PORT)

| SUPERHEAT TEMP. °F | SUCTION PRESSURE AT SERVICE PORT PSIG. | | | | | | | | | | | | | |
|--------------------|--|-----|-----|-----|-----|-----|-----|-----|-----|--|--|--|--|--|
| | 108 | 112 | 117 | 121 | 126 | 131 | 139 | 141 | 146 | | | | | |
| 0 | 35 | 37 | 39 | 41 | 43 | 45 | 47 | 49 | 51 | | | | | |
| 2 | 37 | 39 | 41 | 43 | 45 | 47 | 49 | 51 | 53 | | | | | |
| 4 | 39 | 41 | 43 | 45 | 47 | 49 | 51 | 53 | 55 | | | | | |
| 6 | 41 | 43 | 45 | 47 | 49 | 51 | 53 | 55 | 57 | | | | | |
| 8 | 43 | 45 | 47 | 49 | 51 | 53 | 55 | 57 | 59 | | | | | |
| 10 | 45 | 47 | 49 | 51 | 53 | 55 | 57 | 59 | 61 | | | | | |
| 12 | 47 | 49 | 51 | 53 | 55 | 57 | 59 | 61 | 63 | | | | | |
| 14 | 49 | 51 | 53 | 55 | 57 | 59 | 61 | 63 | 65 | | | | | |
| 16 | 51 | 53 | 55 | 57 | 59 | 61 | 63 | 65 | 67 | | | | | |
| 18 | 53 | 55 | 57 | 59 | 61 | 63 | 65 | 67 | 69 | | | | | |
| 20 | 55 | 57 | 59 | 61 | 63 | 65 | 67 | 69 | 71 | | | | | |
| 22 | 57 | 59 | 61 | 63 | 65 | 67 | 69 | 71 | 73 | | | | | |
| 24 | 59 | 61 | 63 | 65 | 67 | 69 | 71 | 73 | 75 | | | | | |
| 26 | 61 | 63 | 65 | 67 | 69 | 71 | 73 | 75 | 77 | | | | | |
| 28 | 63 | 65 | 67 | 69 | 71 | 73 | 75 | 77 | 79 | | | | | |
| 30 | 65 | 67 | 69 | 71 | 73 | 75 | 77 | 79 | 81 | | | | | |

COOLING ONLY CHARGING PROCEDURE

1. Operate unit a minimum of 10 minutes before checking charge.
2. Measure suction pressure by attaching an accurate gage to suction valve service port.
3. Measure suction temperature by attaching an accurate thermistor type or electronic thermometer to the suction line at service valve.
4. Measure outdoor air dry-bulb temperature with a thermometer.
5. Measure indoor air (entering indoor coil) wet-bulb temperature with a sling psychrometer.
6. Refer to Table I. Find outdoor temperature and evaporator entering air wet-bulb temperature. At this intersection, note superheat. Where a dash (-) appears on table do not attempt to charge system under these conditions or refrigerant slugging may occur. Charge must be weighed in, adding or removing 0.6 oz/ft of 3/8 liquid line above or below 15 ft, respectively.
7. Refer to Table II. Find superheat temperature located in step 6 and suction pressure. At this intersection note suction line temperature.
8. If unit has a higher suction line temperature than charted temperature, add refrigerant until charted temperature is reached.
9. If unit has a lower suction line temperature than charted temperature, remove and recover refrigerant until charted temperature is reached.
10. When adding refrigerant, charge in liquid form into the suction service port using a flow-restricting device.
11. If outdoor air temperature or pressure at suction valve changes, charge to new suction line temperature indicated on chart.
12. This procedure is valid when indoor air flow is within +/- 21% of its rated cfm



336878-101 USED ON MODELS: 5 TON, 460-3 PHASE

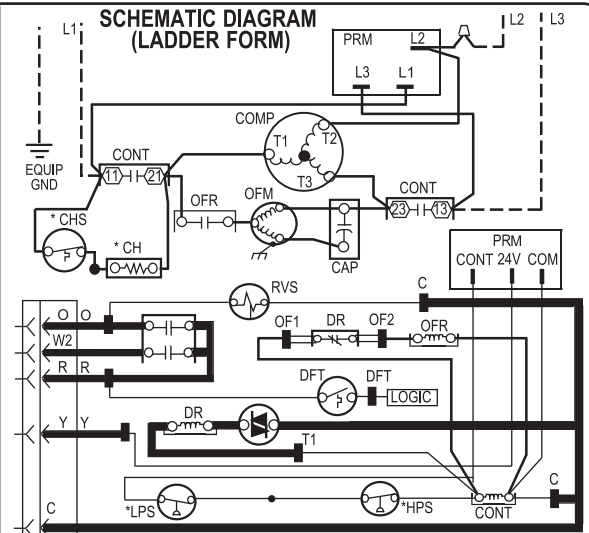
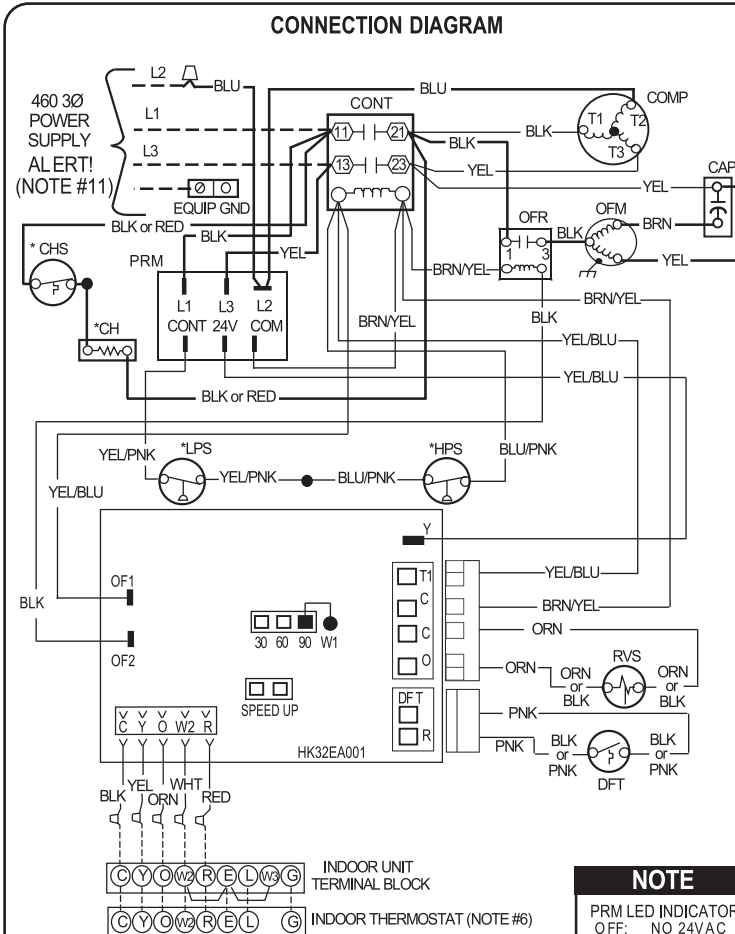

FIELD SELECTED TIME PERIOD BETWEEN DEFROST CYCLES (MINUTES)
 90
 60
 30

SPEED UP JUMPERED TEST PINS (USE METAL OBJECT), FIELD SPEED-UP CYCLE

HEAT CYCLE: 90 MIN. ACCELERATED TO 21 SEC.
 60 MIN. ACCELERATED TO 14 SEC.
 30 MIN. ACCELERATED TO 7 SEC.

DEFROST CYCLE: 90 MIN. ACCELERATED TO 2 SEC.

CONDENSING UNIT CHARGING INSTRUCTIONS
 For use with units using R-410A refrigerant

| REQUIRED LIQUID LINE TEMPERATURE | | REQUIRED SUBCOOLING TEMPERATURE (°F) | | | | | |
|---|-----|--------------------------------------|-----|-----|-----|-----|----|
| Liquid Pressure at Service Valve (psig) | | Required Subcooling Temperature (°F) | | | | | |
| | | 6 | 8 | 10 | 12 | 14 | 16 |
| 251 | 78 | 76 | 74 | 72 | 70 | 68 | |
| 259 | 80 | 78 | 76 | 74 | 72 | 70 | |
| 266 | 82 | 80 | 78 | 76 | 74 | 72 | |
| 274 | 84 | 82 | 80 | 78 | 76 | 74 | |
| 283 | 86 | 84 | 82 | 80 | 78 | 76 | |
| 291 | 88 | 86 | 84 | 82 | 80 | 78 | |
| 299 | 90 | 88 | 86 | 84 | 82 | 80 | |
| 308 | 92 | 90 | 88 | 86 | 84 | 82 | |
| 317 | 94 | 92 | 90 | 88 | 86 | 84 | |
| 326 | 96 | 94 | 92 | 90 | 88 | 86 | |
| 335 | 98 | 96 | 94 | 92 | 90 | 88 | |
| 345 | 100 | 98 | 96 | 94 | 92 | 90 | |
| 354 | 102 | 100 | 98 | 96 | 94 | 92 | |
| 364 | 104 | 102 | 100 | 98 | 96 | 94 | |
| 374 | 106 | 104 | 102 | 100 | 98 | 96 | |
| 384 | 108 | 106 | 104 | 102 | 100 | 98 | |
| 395 | 110 | 108 | 106 | 104 | 102 | 100 | |
| 406 | 112 | 110 | 108 | 106 | 104 | 102 | |
| 416 | 114 | 112 | 110 | 108 | 106 | 104 | |
| 427 | 116 | 114 | 112 | 110 | 108 | 106 | |
| 439 | 118 | 116 | 114 | 112 | 110 | 108 | |
| 450 | 120 | 118 | 116 | 114 | 112 | 110 | |
| 462 | 122 | 120 | 118 | 116 | 114 | 112 | |
| 474 | 124 | 122 | 120 | 118 | 116 | 114 | |

- COOLING ONLY CHARGING PROCEDURE**
- Only use subcooling charging method when OD ambient is greater than 70°F and less than 100°F, indoor temp is greater than 70°F and less than 80°F, and line set is less than 80 ft.
 - Operate unit a minimum of 15 minutes before checking the charge.
 - Measure liquid service valve pressure by attaching an accurate gauge to the service port.
 - Measure the liquid line temperature by attaching an accurate thermistor type or electronic thermometer to the liquid line near the outdoor coil.
 - Refer to unit rating plate for required subcooling temperature.
 - Find the point where the required subcooling temperature intersects the measured liquid service valve pressure.
 - To obtain the required subcooling temperature at specific liquid line pressure, add refrigerant if liquid line temperature is higher than indicated. When adding refrigerant, charge in liquid form using a flow restricting device into suction service port. Recover refrigerant if temperature is lower. Allow a tolerance of +/- 3°F.

NOTE
 PRM LED INDICATOR
 OFF: NO 24VAC
 ON: OK
 FLASH: PHASE PROBLE

LEGEND

- FACTORY POWER WIRING
- FACTORY CONTROL WIRING
- FIELD CONTROL WIRING
- - - - - FIELD POWER WIRING
- CONDUCTOR ON CIRCUIT BOARD
- COMPONENT CONNECTION
- 1/4-INCH QUICK CONNECT TERMINALS
- FIELD SPLICE
- JUNCTION
- CAP CAPACITOR
- *CH CRANKCASE HEATER
- *CHS CRANKCASE HEATER SWITCH
- COMP COMPRESSOR
- CONT CONTACTOR
- CB CIRCUIT BOARD
- DFT DEFROST THERMOSTAT
- DR DEFROST RELAY AND CIRCUITRY
- *HPS HIGH PRESSURE SWITCH
- *LPS LOW PRESSURE SWITCH
- OFM OUTDOOR FAN MOTOR
- OFR OUTDOOR FAN RELAY
- PRM PHASE ROTATION MONITOR
- RVS REVERSING VALVE SOLENOID

- * MAY BE FACTORY INSTALLED**
- NOTES:**
- Symbols are electrical representation only.
 - Compressor and fan motor furnished with inherent thermal protection.
 - To be wired in accordance with National Electric N.E.C. and local codes.
 - N.E.C. class 2, 24 V circuit, min. 40 VA required, 60 VA on units installed with LLS.
 - Use copper conductors only. Use conductors suitable for at least 75°C (167°F).
 - Must use thermostat and sub-base as stated in pre-sale literature.
 - If indoor section has a transformer with a grounded secondary, connect the grounded side to the BRN/YEL lead.
 - If any of the original wire, as supplied, must be replaced, use the same or equivalent wire.
 - Check all electrical connections inside control box for tightness.
 - Do not attempt to operate unit until service valves have been opened.
 - It is imperative to connect 3Ø field power to unit with correct phasing. The Phase Rotation Monitor will not allow the contactor to be energized if the phasing is not correct. If phasing is reversed, simply interchange any two of the three power connections on the field side.
 - Use conductors suitable for at least 75°C (167°F).

CAUTION

- Compressor damage may occur if system is over charged.
- This unit is factory charged with R-410A in accordance with the amount shown on the rating plate. The charge is adequate for most systems using matched coils and tubing not over 15 feet long. Check refrigerant charge for maximum efficiency. See Product Data Literature for required Indoor air Flow Rates and for use of line lengths over 15 feet.
- Relieve pressure and recover all refrigerant before system repair or final disposal. Use all service ports and open all flow-control devices, including solenoid valves.
- Never vent refrigerant to atmosphere. Use approved recovery equipment.



335878-101 REV. B