

# WIRING DIAGRAM MANUAL

## Split System Air Conditioner

### N4A7

#### Safety Labeling and Signal Words

##### **DANGER, WARNING, CAUTION, and NOTE**

The signal words **DANGER**, **WARNING**, **CAUTION**, and **NOTE** are used to identify levels of hazard seriousness. The signal word **DANGER** is only used on product labels to signify an immediate hazard. The signal words **WARNING**, **CAUTION**, and **NOTE** will be used on product labels and throughout this manual and other manuals that may apply to the product.

**DANGER** - Immediate hazards which **will** result in severe personal injury or death.

**WARNING** - Hazards or unsafe practices which **could** result in severe personal injury or death.

**CAUTION** - Hazards or unsafe practices which **may** result in minor personal injury or product or property damage.

**NOTE** - Used to highlight suggestions which **will** result in enhanced installation, reliability, or operation.

##### Signal Words in Manuals

The signal word **WARNING** is used throughout this manual in the following manner:



The signal word **CAUTION** is used throughout this manual in the following manner:



##### Signal Words on Product Labeling

Signal words are used in combination with colors and/or pictures on product labels.

#### TABLE OF CONTENTS

336323- 101 Wiring Diagram ..... 2

<b>Voltage</b>	208/230- 1- 60
<b>Model No.</b>	N4A7

WARNING

**DEATH, PERSONAL INJURY, AND/OR PROPERTY DAMAGE HAZARD**

**Failure to carefully read and follow this warning could result in equipment malfunction, property damage, personal injury and/or death.**

**Installation or repairs made by unqualified persons could result in equipment malfunction, property damage, personal injury and/or death.**

**The information contained in this manual is intended for use by a qualified service technician familiar with safety procedures and equipped with the proper tools and test instruments.**

**Installation must conform with local building codes and with the National Electrical Code NFPA70 current edition or Canadian Electrical Code Part 1 CSA C.22.1.**

# 336323-101

## CONNECTION DIAGRAM

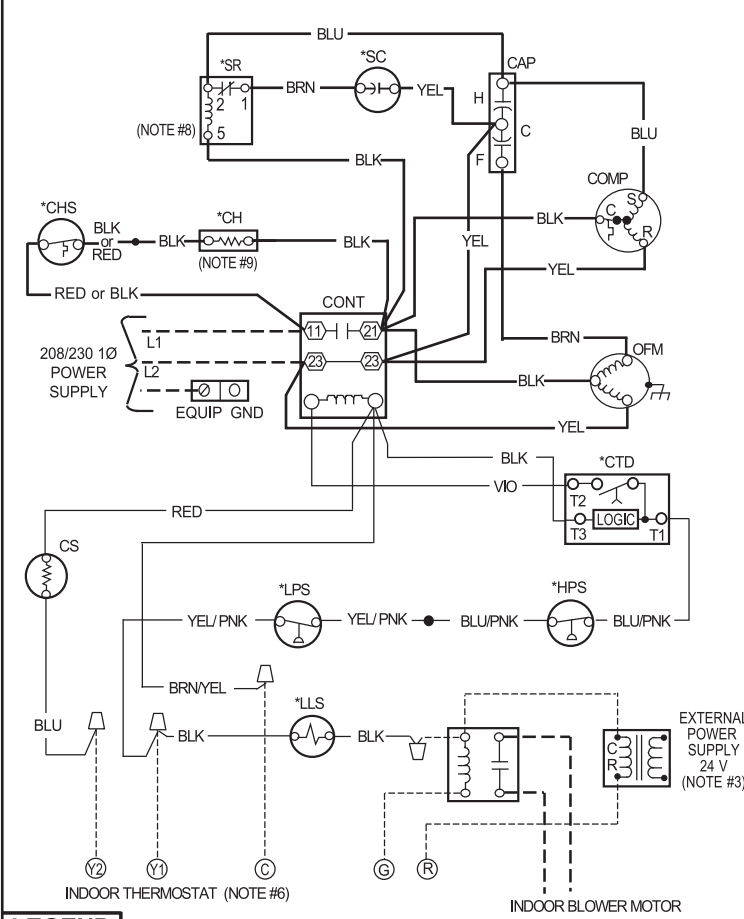

## SCHEMATIC DIAGRAM (LADDER FORM)

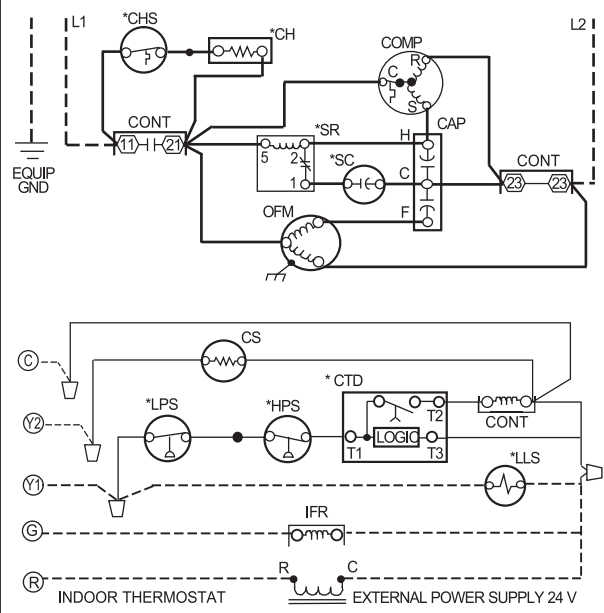

### CONDENSING UNIT CHARGING INSTRUCTIONS For use with units using R-410A refrigerant

#### REQUIRED LIQUID LINE TEMPERATURE

Liquid Pressure at Service Valve (psig)	Required Subcooling Temperature (°F)					
	6	8	10	12	14	16
251	78	76	74	72	70	68
259	80	78	76	74	72	70
266	82	80	78	76	74	72
274	84	82	80	78	76	74
283	86	84	82	80	78	76
291	88	86	84	82	80	78
299	90	88	86	84	82	80
308	92	90	88	86	84	82
317	94	92	90	88	86	84
326	96	94	92	90	88	86
335	98	96	94	92	90	88
345	100	98	96	94	92	90
354	102	100	98	96	94	92
364	104	102	100	98	96	94
374	106	104	102	100	98	96
384	108	106	104	102	100	98
395	110	108	106	104	102	100
406	112	110	108	106	104	102
416	114	112	110	108	106	104
427	116	114	112	110	108	106
439	118	116	114	112	110	108
450	120	118	116	114	112	110
462	122	120	118	116	114	112
474	124	122	120	118	116	114

#### COOLING ONLY CHARGING PROCEDURE

1. Only use subcooling charging method when OD ambient is greater than 70°F and less than 100°F, indoor temp is greater than 70°F and less than 80°F, and line set is less than 80 ft.
2. Operate unit a minimum of 15 minutes before checking the charge.
3. Measure liquid service valve pressure by attaching an accurate gauge to the service port.
4. Measure the liquid line temperature by attaching an accurate thermistor type or electronic thermometer to the liquid line near the outdoor coil.
5. Refer to unit rating plate for required subcooling temperature.
6. Find the point where the required subcooling temperature intersects the measured liquid service valve pressure.
7. To obtain the required subcooling temperature at specific liquid line pressure, add refrigerant if liquid line temperature is higher than indicated. When adding refrigerant, charge in liquid form using a flow restricting device into suction service port. Recover refrigerant if temperature is lower. Allow a tolerance of +/- 3°F.

### LEGEND

- FACTORY POWER WIRING
- FACTORY CONTROL WIRING
- - - FIELD CONTROL WIRING
- - - FIELD POWER WIRING
- CONDUCTOR ON CIRCUIT BOARD
- COMPONENT CONNECTION
- ⊕ FIELD SPLICE
- JUNCTION
- ⊏ PLUG RECEPTACLE
- CAP CAPACITOR
- \*CH CRANKCASE HEATER
- \*CHS CRANKCASE HEATER SWITCH
- COMP COMPRESSOR
- CONT CONTACTOR
- CS COMPRESSOR SOLENOID
- \*CTD COMPRESSOR TIME DELAY
- \*HPS HIGH PRESSURE SWITCH
- IFR INDOOR FAN RELAY
- \*LLS LIQUID LINE SOLENOID VALVE
- \*LPS LOW PRESSURE SWITCH
- OFM OUTDOOR FAN MOTOR
- \*SC START CAPACITOR
- \*SR START RELAY

\* MAY BE FACTORY INSTALLED

### NOTES:

1. Symbols are electrical representation only.
2. Compressor and fan motor furnished with inherent thermal protection.
3. To be wired in accordance with National Electric N.E.C. and local codes.
4. N.E.C. class 2, 24 V circuit, min. 40 VA required, 60 VA on units installed with LLS.
5. Use copper conductors only. Use conductors suitable for at least 75°C (167°F).
6. Connection for typical cooling only thermostat. For other arrangements see Installation Instructions.
7. If indoor section has a transformer with a grounded secondary, connect the grounded side to the BRN/YEL lead.
8. When start relay and start capacitor are installed, start thermistor is not used.
9. CH not used on all units.
10. If any of the original wire, as supplied, must be replaced, use the same or equivalent wire.
11. Check all electrical connections inside control box for tightness.
12. Do not attempt to operate unit until service valves have been opened.
13. Do not rapid cycle compressor. Compressor must be off 3 minutes to allow pressures to equalize between high and low side before starting.

### CAUTION

1. Compressor damage may occur if system is over charged.
2. This unit is factory charged with R-410A in accordance with the amount shown on the rating plate. The charge is adequate for most systems using matched coils and tubing not over 15 feet long. Check refrigerant charge for maximum efficiency. See Product Data Literature for required Indoor air Flow Rates and for use of line lengths over 15 feet.
3. Relieve pressure and recover all refrigerant before system repair or final disposal. Use all service ports and open all flow-control devices, including solenoid valves.
4. Never vent refrigerant to atmosphere. Use approved recovery equipment.



336323-101 REV. B