

TECHNICAL SUPPORT MANUAL

Split System Air Conditioner

N2A3, 3-Phase

Safety Labeling and Signal Words

DANGER, WARNING, CAUTION, and NOTE

The signal words **DANGER**, **WARNING**, **CAUTION**, and **NOTE** are used to identify levels of hazard seriousness. The signal word **DANGER** is only used on product labels to signify an immediate hazard. The signal words **WARNING**, **CAUTION**, and **NOTE** will be used on product labels and throughout this manual and other manuals that may apply to the product.

DANGER - Immediate hazards which **will** result in severe personal injury or death.

WARNING - Hazards or unsafe practices which **could** result in severe personal injury or death.

CAUTION - Hazards or unsafe practices which **may** result in minor personal injury or product or property damage.

NOTE - Used to highlight suggestions which **will** result in enhanced installation, reliability, or operation.

Signal Words in Manuals

The signal word **WARNING** is used throughout this manual in the following manner:



The signal word **CAUTION** is used throughout this manual in the following manner:



Signal Words on Product Labeling

Signal words are used in combination with colors and/or pictures on product labels.

TABLE OF CONTENTS

Wiring Diagrams	2 - 3
Charging Chart	4
Tech Labels	5 - 8
Condenser Only Data	9 - 10
Multiplying Factors	11 - 14
Exploded Drawings	15 - 18
Parts List	19 - 20
Model Number Identification	21



DEATH, PERSONAL INJURY, AND/OR PROPERTY DAMAGE HAZARD

Failure to carefully read and follow this warning could result in equipment malfunction, property damage, personal injury and/or death.

Installation or repairs made by unqualified persons could result in equipment malfunction, property damage, personal injury and/or death.

The information contained in this manual is intended for use by a qualified service technician familiar with safety procedures and equipped with the proper tools and test instruments.

Installation must conform with local building codes and with the National Electrical Code NFPA70 current edition or Canadian Electrical Code Part 1 CSA C.22.1.

CONNECTION DIAGRAM

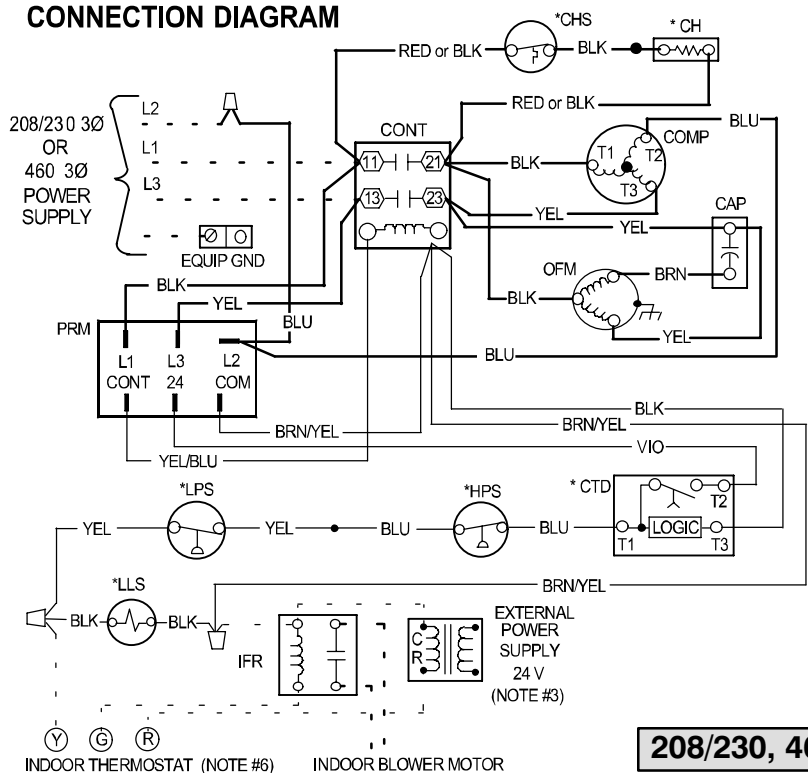

SCHEMATIC DIAGRAM (LADDER FORM)

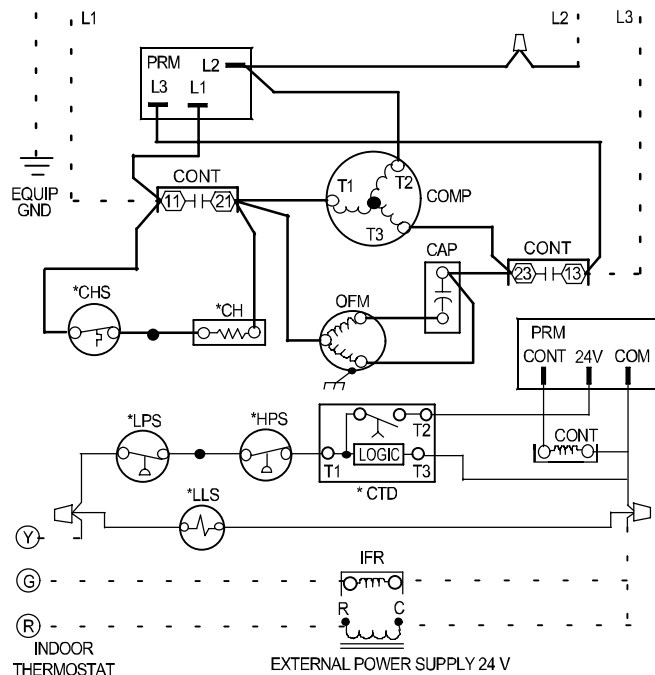

208/230, 460 Volt Model Sizes: 36, 42, 48, 60

1. Symbols are electrical representation only.
2. Compressor and fan motor furnished with inherent thermal protection.
3. To be wired in accordance with National Electric N.E.C. and local codes.
4. N.E.C. class 2, 24 V circuit, min. 40 VA required, 60 VA on units installed with LLS.
5. Use copper conductors only. Use conductors suitable for at least 75°C (167°F).
6. Connection for typical cooling only thermostat. For other arrangements see installation instructions.
7. If indoor section has a transformer with a grounded secondary, connect the grounded side to the BRN/YEL lead.
8. When start capacitor and relay are installed, start thermistor (PTC) is not used.
9. CH not used on all units.
10. If any of the original wire, as supplied, must be replaced, use the same or equivalent wire.
11. Check all electrical connections inside control box for tightness.
12. Do not attempt to operate unit until service valves have been opened.
13. Do not rapid cycle compressor. Compressor must be off 3 minutes to allow pressures to equalize between high and low side before starting.
14. Wire not present if HPS, LPS or CTD are used.

LEGEND

—	FACTORY POWER WIRING
---	FACTORY CONTROL WIRING
- - -	FIELD CONTROL WIRING
- - -	FIELD POWER WIRING
○	COMPONENT CONNECTION
○	FIELD SPLICE
●	JUNCTION
⏏	PLUG RECEPTACLE
CONT	CONTACTOR
CAP	CAPACITOR (DUAL RUN)
*CH	CRANKCASE HEATER
*CHS	CRANKCASE HEATER SWITCH
COMP	COMPRESSOR
*CTD	COMPRESSOR TIME DELAY
*DTS	DISCHARGE TEMP SWITCH
*HPS	HIGH PRESSURE SWITCH
IFR	INDOOR FAN RELAY
*LLS	LIQ LINE SOLENOID VALVE
*LPS	LOW PRESSURE SWITCH
OFM	OUTDOOR FAN MOTOR
*SC	START CAPICATOR
*SR	START RELAY
*ST	START THERMISTOR

* MAY BE FACTORY INSTALLED

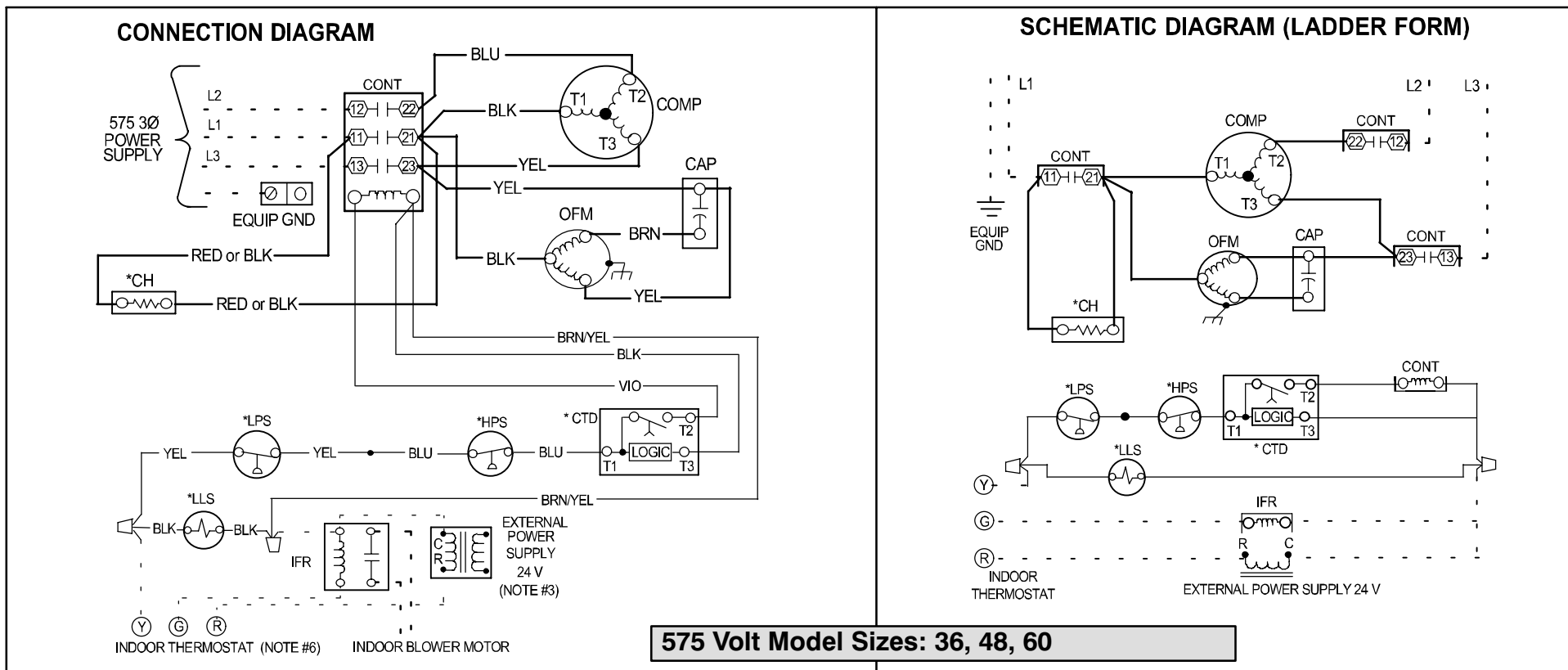

575 Volt Model Sizes: 36, 48, 60

1. Symbols are electrical representation only.
2. Compressor and fan motor furnished with inherent thermal protection.
3. To be wired in accordance with National Electric N.E.C. and local codes.
4. N.E.C. class 2, 24 V circuit, min. 40 VA required, 60 VA on units installed with LLS.
5. Use copper conductors only. Use conductors suitable for at least 75°C (167°F).
6. Connection for typical cooling only thermostat. For other arrangements see installation instructions.
7. If indoor section has a transformer with a grounded secondary, connect the grounded side to the BRN/YEL lead.
8. When start capacitor and relay are installed, start thermistor (PTC) is not used.
9. CH not used on all units.
10. If any of the original wire, as supplied, must be replaced, use the same or equivalent wire.
11. Check all electrical connections inside control box for tightness.
12. Do not attempt to operate unit until service valves have been opened.
13. Do not rapid cycle compressor. Compressor must be off 3 minutes to allow pressures to equalize between high and low side before starting.
14. Wire not present if HPS, LPS or CTD are used.

LEGEND

—	FACTORY POWER WIRING
—	FACTORY CONTROL WIRING
- - -	FIELD CONTROL WIRING
- - -	FIELD POWER WIRING
- - -	COMPONENT CONNECTION
○	FIELD SPICE
●	JUNCTION
⏏	PLUG RECEPTACLE
CONT	CONTACTOR
CAP	CAPACITOR (DUAL RUN)
*CH	CRANKCASE HEATER
*CHS	CRANKCASE HEATER SWITCH
COMP	COMPRESSOR
*CTD	COMPRESSOR TIME DELAY
*DTS	DISCHARGE TEMP SWITCH
*HPS	HIGH PRESSURE SWITCH
IFR	INDOOR FAN RELAY
*LLS	LIQ LINE SOLENOID VALVE
*LPS	LOW PRESSURE SWITCH
OFM	OUTDOOR FAN MOTOR
*SC	START CAPICATOR
*SR	START RELAY
*ST	START THERMISTOR

* MAY BE FACTORY INSTALLED

R-22 CHARGING CHART

- Find the required Subcooling Temperature on the unit Rating Plate. Use the closest column on the chart below (5, 10, 15, or 20) .
- Add or remove refrigerant until both the Liquid Line Temperature and Liquid Pressure agree with chart data.

Measured Liquid Pressure (psig)	Rating Plate (required) Subcooling Temperature (°F)			
	5	10	15	20
R-22 Required Liquid Line Temperature (°F)				
134	71	66	61	56
141	74	69	64	59
148	77	72	67	62
156	80	75	70	65
163	83	78	73	68
171	86	81	76	71
179	89	84	79	74
187	92	87	82	77
196	95	90	85	80
205	98	93	88	83
214	101	96	91	86
223	104	99	94	89
233	107	102	97	92
243	110	105	100	95
253	113	108	103	98
264	116	111	106	101
274	119	114	109	104
285	122	117	112	107
297	125	120	115	110
309	128	123	118	113
321	131	126	121	116
331	134	129	124	119
346	137	132	127	122
359	140	135	130	125

N2A336 COOLING		With EB*2X36*** Indoor																			
		Outdoor Ambient Temperature - Degrees F, Dry Bulb																			
		75				85				95				105				115			
		Entering Indoor Temperature - Degrees F, Wet Bulb																			
CFM		72	67	62	57	72	67	62	57	72	67	62	57	72	67	62	57	72	67	62	57
1000	MBh†	39.90	36.23	33.18	32.42	38.51	34.96	32.05	31.48	37.08	33.65	30.87	30.51	35.60	32.29	29.68	29.49	34.07	30.88	28.47	28.43
	S/T‡	0.53	0.71	0.92	1.00	0.53	0.72	0.94	1.00	0.54	0.74	0.96	1.00	0.55	0.75	0.97	1.00	0.55	0.77	0.99	1.00
	AMPS*	11.29	11.14	11.02	10.99	12.33	12.18	12.06	12.04	13.49	13.35	13.23	13.22	14.79	14.64	14.53	14.52	16.23	16.08	15.97	15.97
	HI PR	157	156	155	155	186	185	183	183	218	216	214	214	253	250	248	248	290	287	285	285
	LO PR	82	74	67	66	83	75	69	67	84	76	70	69	85	78	71	71	87	79	73	73
1150	MBh†	40.59	36.89	34.02	33.77	39.13	35.56	32.87	32.77	37.65	34.20	31.68	31.73	36.12	32.80	30.64	30.65	34.52	31.34	29.51	29.52
	S/T‡	0.55	0.75	0.97	1.00	0.55	0.76	0.98	1.00	0.56	0.77	1.00	1.00	0.57	0.79	1.00	1.00	0.58	0.81	1.00	1.00
	AMPS*	11.57	11.42	11.31	11.30	12.61	12.46	12.35	12.34	13.77	13.62	13.52	13.52	15.07	14.92	14.83	14.83	16.50	16.36	16.28	16.28
	HI PR	158	156	155	155	187	185	184	184	219	217	215	215	253	251	249	249	290	288	286	286
	LO PR	84	76	70	69	85	77	71	71	86	78	72	72	87	79	74	74	89	81	76	76
1300	MBh†	41.08	37.38	34.84	34.88	39.58	36.01	33.82	33.82	38.05	34.61	32.72	32.72	36.47	33.17	31.58	31.58	34.83	31.68	30.39	30.39
	S/T‡	0.56	0.78	1.00	1.00	0.57	0.79	1.00	1.00	0.58	0.81	1.00	1.00	0.59	0.83	1.00	1.00	0.60	0.85	1.00	1.00
	AMPS*	11.85	11.69	11.59	11.59	12.88	12.73	12.64	12.64	14.04	13.89	13.82	13.81	15.34	15.19	15.12	15.12	16.77	16.63	16.57	16.57
	HI PR	158	157	156	156	187	186	185	185	219	217	216	216	254	251	250	250	291	288	287	287
	LO PR	85	77	72	72	86	78	74	74	87	80	75	75	89	81	77	77	90	82	79	79

† Total capacities are net (I.D. blower heat subtracted) system capacities based on 25' line set.
If additional tubing length and/or indoor unit is located above outdoor unit, a slight variation in capacity may occur.

†† At TVA rating indoor condition (75 °F db, 63 °F wb), all other indoor air temperatures are at 80 °F db
If additional tubing length and/or indoor unit is located above outdoor unit, a slight variation in capacity may occur.

^ System amps are total of indoor and outdoor amps.

‡ Chart data is for 80° F indoor dry bulb. For indoor db temperatures other than 80° F, measure Indoor db and Indoor CFM, and plug these into the formula below. Measure outdoor db and indoor wet bulb, apply these to the chart above, find MBh and S/T, and plug these into the formula below.
(Note: if indoor db is the only thing changing, total capacity, MBh, stays the same.)

Sensible Capacity at Indoor db LOWER than 80 °F = (MBh x S/T) - $\left(\frac{(80 - \text{Indoor db}) \times 835 \times \text{Indoor CFM}}{1000} \right)$

Sensible Capacity at Indoor db HIGHER than 80 °F = (MBh x S/T) + $\left(\frac{(\text{Indoor db} - 80) \times 835 \times \text{Indoor CFM}}{1000} \right)$

N2A342 COOLING		With EB*2X42*** Indoor																			
		Outdoor Ambient Temperature - Degrees F, Dry Bulb																			
		75				85				95				105				115			
		Entering Indoor Temperature - Degrees F, Wet Bulb																			
CFM		72	67	62	57	72	67	62	57	72	67	62	57	72	67	62	57	72	67	62	57
1225	MBh†	47.31	42.97	39.35	38.55	45.67	41.46	38.02	37.44	43.98	39.89	36.65	36.29	42.20	38.27	35.23	35.07	40.35	36.57	33.73	33.78
	S/T‡	0.53	0.72	0.93	1.00	0.54	0.73	0.94	1.00	0.54	0.74	0.96	1.00	0.55	0.75	0.98	1.00	0.56	0.77	1.00	1.00
	AMPS*	13.10	12.95	12.83	12.80	14.37	14.22	14.10	14.08	15.79	15.64	15.52	15.50	17.37	17.21	17.09	17.08	19.11	18.94	18.81	18.81
	HI PR	166	164	163	163	196	194	192	191	228	225	223	223	263	260	257	257	301	298	295	295
	LO PR	85	77	70	69	86	78	72	71	88	80	73	72	89	81	74	74	90	82	76	76
1400	MBh†	48.07	43.67	40.28	40.04	46.36	42.12	38.95	38.86	44.59	40.50	37.57	37.63	42.75	38.82	36.33	36.34	40.83	37.07	34.97	34.97
	S/T‡	0.55	0.75	0.97	1.00	0.55	0.76	0.98	1.00	0.56	0.77	1.00	1.00	0.57	0.79	1.00	1.00	0.58	0.81	1.00	1.00
	AMPS*	13.42	13.26	13.15	13.14	14.68	14.53	14.42	14.42	16.11	15.95	15.84	15.85	17.69	17.53	17.43	17.43	19.42	19.25	19.16	19.16
	HI PR	166	165	163	163	196	194	192	192	229	226	224	224	264	261	259	259	302	298	296	296
	LO PR	87	79	73	72	88	80	74	74	89	81	75	76	91	83	77	77	92	84	79	79
1575	MBh†	48.64	44.25	41.22	41.28	46.87	42.65	40.03	40.04	45.05	40.99	38.73	38.73	43.15	39.26	37.37	37.37	41.18	37.47	35.94	35.94
	S/T‡	0.56	0.78	1.00	1.00	0.57	0.79	1.00	1.00	0.58	0.81	1.00	1.00	0.59	0.83	1.00	1.00	0.60	0.85	1.00	1.00
	AMPS*	13.73	13.57	13.47	13.48	14.99	14.84	14.75	14.75	16.42	16.26	16.18	16.18	17.99	17.84	17.76	17.76	19.73	19.57	19.50	19.50
	HI PR	167	165	164	164	197	194	193	193	229	226	225	225	264	261	260	260	302	299	298	298
	LO PR	89	81	75	75	90	82	77	77	91	83	78	78	92	84	80	80	93	85	82	82

- † Total capacities are net (I.D. blower heat subtracted) system capacities based on 25' line set.
If additional tubing length and/or indoor unit is located above outdoor unit, a slight variation in capacity may occur.
- †† At TVA rating indoor condition (75 °F db, 63 °F wb), all other indoor air temperatures are at 80 °F db
If additional tubing length and/or indoor unit is located above outdoor unit, a slight variation in capacity may occur.
- ^ System amps are total of indoor and outdoor amps.
- ‡ Chart data is for 80° F indoor dry bulb. For indoor db temperatures other than 80° F, measure Indoor db and Indoor CFM, and plug these into the formula below. Measure outdoor db and indoor wet bulb, apply these to the chart above, find MBh and S/T, and plug these into the formula below.
(Note: if indoor db is the only thing changing, total capacity, MBh, stays the same.)

Sensible Capacity at Indoor db LOWER than 80 °F = (MBh x S/T) - $\left(\frac{(80 - \text{Indoor db}) \times 835 \times \text{Indoor CFM}}{1000} \right)$

Sensible Capacity at Indoor db HIGHER than 80 °F = (MBh x S/T) + $\left(\frac{(\text{Indoor db} - 80) \times 835 \times \text{Indoor CFM}}{1000} \right)$

N2A348 COOLING		With EB*2X48*** Indoor																			
		Outdoor Ambient Temperature - Degrees F, Dry Bulb																			
		75				85				95				105				115			
		Entering Indoor Temperature - Degrees F, Wet Bulb																			
CFM		72	67	62	57	72	67	62	57	72	67	62	57	72	67	62	57	72	67	62	57
1400	MBh†	54.29	49.26	44.79	43.36	52.13	47.24	42.95	41.90	49.95	45.19	41.11	40.41	47.78	43.16	39.27	38.91	45.58	41.08	37.46	37.37
	S/T‡	0.52	0.70	0.91	1.00	0.53	0.71	0.93	1.00	0.53	0.73	0.95	1.00	0.54	0.74	0.97	1.00	0.55	0.76	0.99	1.00
	AMPS*	14.87	14.70	14.54	14.49	16.14	15.95	15.77	15.72	17.58	17.35	17.13	17.09	19.18	18.91	18.66	18.63	20.95	20.63	20.34	20.33
	HI PR	168	166	164	164	197	195	193	192	229	227	224	223	265	261	258	258	303	299	295	295
	LO PR	86	78	71	69	87	80	73	71	89	81	74	73	90	82	76	75	91	84	77	77
1600	MBh†	55.34	50.23	45.90	45.23	53.08	48.13	44.03	43.66	50.82	46.00	42.18	42.08	48.57	43.90	40.47	40.48	46.28	41.76	38.85	38.86
	S/T‡	0.54	0.73	0.95	1.00	0.54	0.74	0.97	1.00	0.55	0.76	0.99	1.00	0.56	0.78	1.00	1.00	0.57	0.80	1.00	1.00
	AMPS*	15.23	15.06	14.91	14.88	16.51	16.31	16.14	16.12	17.94	17.72	17.52	17.51	19.55	19.28	19.07	19.07	21.33	21.02	20.79	20.79
	HI PR	168	166	165	164	198	195	193	193	230	227	225	225	265	262	259	259	303	299	297	297
	LO PR	88	80	74	73	89	81	75	74	91	83	76	76	92	84	78	78	93	85	80	80
1800	MBh†	56.11	50.96	46.90	46.76	53.78	48.79	45.07	45.12	51.45	46.61	43.45	43.45	49.13	44.45	41.77	41.77	46.79	42.27	40.06	40.07
	S/T‡	0.55	0.76	0.98	1.00	0.56	0.78	1.00	1.00	0.57	0.79	1.00	1.00	0.58	0.81	1.00	1.00	0.59	0.83	1.00	1.00
	AMPS*	15.58	15.41	15.27	15.26	16.86	16.66	16.51	16.51	18.30	18.07	17.91	17.91	19.91	19.65	19.49	19.49	21.69	21.39	21.22	21.22
	HI PR	169	167	165	165	198	196	194	194	231	228	226	226	266	263	260	260	304	300	298	298
	LO PR	90	82	76	75	91	83	77	77	92	84	79	79	93	85	81	81	95	87	83	83

† Total capacities are net (I.D. blower heat subtracted) system capacities based on 25' line set.

If additional tubing length and/or indoor unit is located above outdoor unit, a slight variation in capacity may occur.

†† At TVA rating indoor condition (75 °F db, 63 °F wb), all other indoor air temperatures are at 80 °F db

If additional tubing length and/or indoor unit is located above outdoor unit, a slight variation in capacity may occur.

^ System amps are total of indoor and outdoor amps.

‡ Chart data is for 80° F indoor dry bulb. For indoor db temperatures other than 80° F, measure Indoor db and Indoor CFM, and plug these into the formula below. Measure outdoor db and indoor wet bulb, apply these to the chart above, find MBh and S/T, and plug these into the formula below.

(Note: if indoor db is the only thing changing, total capacity, MBh, stays the same.)

$$\text{Sensible Capacity at Indoor db LOWER than } 80^\circ\text{F} = (\text{MBh} \times \text{S/T}) - \left(\frac{(80 - \text{Indoor db}) \times 835 \times \text{Indoor CFM}}{1000} \right)$$

$$\text{Sensible Capacity at Indoor db HIGHER than } 80^\circ\text{F} = (\text{MBh} \times \text{S/T}) + \left(\frac{(\text{Indoor db} - 80) \times 835 \times \text{Indoor CFM}}{1000} \right)$$

N2A360 COOLING		With ED*2X60*** Indoor																			
		Outdoor Ambient Temperature - Degrees F, Dry Bulb																			
		75				85				95				105				115			
		Entering Indoor Temperature - Degrees F, Wet Bulb																			
CFM		72	67	62	57	72	67	62	57	72	67	62	57	72	67	62	57	72	67	62	57
1750	MBh†	66.68	60.79	55.74	54.40	64.21	58.51	53.68	52.72	61.64	56.12	51.54	50.94	58.95	53.64	49.34	49.07	56.14	51.03	47.05	47.10
	S/T‡	0.53	0.71	0.92	1.00	0.53	0.72	0.94	1.00	0.54	0.74	0.96	1.00	0.55	0.75	0.98	1.00	0.56	0.77	1.00	1.00
	AMPS*	18.07	17.93	17.81	17.78	19.89	19.74	19.61	19.59	21.92	21.74	21.60	21.58	24.13	23.93	23.77	23.76	26.53	26.30	26.11	26.11
	HI PR	177	175	172	172	207	204	201	201	240	236	233	233	276	271	268	268	314	309	305	306
	LO PR	90	81	74	72	91	83	75	74	92	84	77	76	94	85	78	78	95	87	80	80
2000	MBh†	67.80	61.85	57.03	56.54	65.22	59.47	54.95	54.74	62.55	57.00	52.81	52.85	59.77	54.43	50.87	50.88	56.85	51.74	48.77	48.78
	S/T‡	0.55	0.75	0.97	1.00	0.55	0.76	0.98	1.00	0.56	0.77	1.00	1.00	0.57	0.79	1.00	1.00	0.58	0.81	1.00	1.00
	AMPS*	18.50	18.36	18.25	18.24	20.33	20.18	20.06	20.05	22.36	22.18	22.05	22.05	24.57	24.38	24.24	24.24	26.97	26.75	26.61	26.61
	HI PR	178	175	173	173	208	205	202	202	241	237	234	234	277	272	269	269	315	310	308	308
	LO PR	92	84	77	76	93	85	78	78	95	86	79	79	96	87	81	81	97	88	83	83
2250	MBh†	68.61	62.64	58.24	58.29	65.94	60.19	56.40	56.40	63.20	57.65	54.41	54.42	60.34	55.02	52.33	52.33	57.34	52.27	50.12	50.13
	S/T‡	0.56	0.78	1.00	1.00	0.57	0.79	1.00	1.00	0.58	0.81	1.00	1.00	0.59	0.83	1.00	1.00	0.60	0.85	1.00	1.00
	AMPS*	18.93	18.79	18.69	18.69	20.76	20.60	20.50	20.50	22.79	22.61	22.51	22.51	25.01	24.81	24.71	24.71	27.41	27.19	27.09	27.09
	HI PR	179	176	174	174	209	206	203	203	242	238	236	236	277	273	271	271	316	311	309	309
	LO PR	94	85	79	79	95	86	81	81	96	87	82	82	97	89	84	84	99	90	86	86

- † Total capacities are net (I.D. blower heat subtracted) system capacities based on 25' line set.
If additional tubing length and/or indoor unit is located above outdoor unit, a slight variation in capacity may occur.
- †† At TVA rating indoor condition (75 °F db, 63 °F wb), all other indoor air temperatures are at 80 °F db
If additional tubing length and/or indoor unit is located above outdoor unit, a slight variation in capacity may occur.
- ^ System amps are total of indoor and outdoor amps.
- ‡ Chart data is for 80° F indoor dry bulb. For indoor db temperatures other than 80° F, measure Indoor db and Indoor CFM, and plug these into the formula below. Measure outdoor db and indoor wet bulb, apply these to the chart above, find MBh and S/T, and plug these into the formula below.
(Note: if indoor db is the only thing changing, total capacity, MBh, stays the same.)

$$\text{Sensible Capacity at Indoor db LOWER than } 80\text{ }^\circ\text{F} = (\text{MBh} \times \text{S/T}) - \left(\frac{(80 - \text{Indoor db}) \times 835 \times \text{Indoor CFM}}{1000} \right)$$

$$\text{Sensible Capacity at Indoor db HIGHER than } 80\text{ }^\circ\text{F} = (\text{MBh} \times \text{S/T}) + \left(\frac{(\text{Indoor db} - 80) \times 835 \times \text{Indoor CFM}}{1000} \right)$$

Data for Condenser Only (Cooling)									
Saturated Suction Temperature °F		Condenser Entering Air Temperature °F							
		55	65	75	85	95	105	115	125
N2A336*HA, N2A336*LA, N2A336ASA									
30	TCG	32.00	30.50	29.10	27.60	26.10	24.60	23.00	21.50
	SDT	73.90	82.60	91.40	100.40	109.50	118.70	128.00	137.30
	KW	1.73	1.91	2.11	2.34	2.60	2.89	3.20	3.55
35	TCG	35.10	33.70	32.10	30.50	28.80	27.20	25.50	23.90
	SDT	75.20	84.30	93.00	101.90	110.90	120.00	129.20	138.50
	KW	1.74	1.94	2.14	2.37	2.63	2.92	3.23	3.58
40	TCG	38.70	37.00	35.30	33.60	31.80	30.00	28.20	26.40
	SDT	77.70	86.10	94.70	103.50	112.40	121.40	130.50	139.70
	KW	1.79	1.97	2.17	2.40	2.66	2.95	3.27	3.61
45	TCG	42.50	40.60	38.70	36.80	34.90	33.00	31.10	29.10
	SDT	79.80	88.00	96.50	105.10	113.90	122.90	131.90	141.00
	KW	1.82	2.00	2.21	2.44	2.70	2.98	3.30	3.65
50	TCG	46.40	44.40	42.40	40.30	38.20	36.20	34.00	31.90
	SDT	82.00	90.10	98.40	106.90	115.50	124.40	133.30	142.30
	KW	1.86	2.04	2.25	2.48	2.73	3.02	3.34	3.69
55	TCG	50.70	48.50	46.30	44.00	41.70	39.50	37.20	34.90
	SDT	84.30	92.20	100.40	108.70	117.30	126.00	134.80	143.70
	KW	1.91	2.09	2.29	2.52	2.77	3.06	3.38	3.72
N2A342*HA, N2A342*LA									
30	TCG	34.10	32.70	31.10	29.60	28.80	26.30	24.70	22.90
	SDT	72.90	81.90	91.00	100.10	104.80	118.70	128.00	137.40
	KW	1.96	2.19	2.44	2.72	2.88	3.38	3.75	4.15
35	TCG	37.60	36.00	34.30	32.70	31.80	29.20	27.40	25.50
	SDT	74.60	83.50	92.50	101.60	106.20	120.00	129.30	138.60
	KW	1.99	2.22	2.47	2.75	2.90	3.41	3.79	4.20
40	TCG	41.20	39.50	37.80	36.00	35.00	32.20	30.30	28.30
	SDT	76.50	85.20	94.10	103.10	107.60	121.40	130.60	139.80
	KW	2.02	2.25	2.50	2.78	2.94	3.45	3.83	4.24
45	TCG	45.20	43.30	41.40	39.50	38.50	35.40	33.40	31.20
	SDT	78.40	87.00	95.80	104.70	109.20	122.80	132.00	141.10
	KW	2.06	2.28	2.53	2.82	2.97	3.48	3.87	4.28
50	TCG	49.30	47.30	45.30	43.20	42.10	38.80	36.60	34.30
	SDT	80.50	89.00	97.60	106.40	110.80	124.30	133.40	142.50
	KW	2.09	2.32	2.57	2.85	3.01	3.52	3.91	4.33
55	TCG	53.80	51.60	49.40	47.10	46.00	42.40	40.00	37.50
	SDT	82.60	91.00	99.50	108.20	112.60	125.90	134.90	143.90
	KW	2.13	2.36	2.61	2.89	3.05	3.56	3.95	4.37

TCG = Gross Cooling Capacity (x 1000 BTU/hr)
 SDT = Saturated Temperature Leaving Compressor
 kW = Outdoor Unit Kilowatts

Data for Condenser Only (Cooling)									
Saturated Suction Temperature °F		Condenser Entering Air Temperature °F							
		55	65	75	85	95	105	115	125
N2A348*HA, N2A348*LA, N2A348ASA									
30	TCG	43.30	40.70	38.10	35.60	33.10	30.50	28.00	25.60
	SDT	72.60	81.40	90.20	99.20	108.30	117.40	126.60	135.90
	KW	2.32	2.53	2.75	3.00	3.26	3.54	3.84	4.15
35	TCG	48.10	45.40	42.70	40.00	37.30	34.70	32.00	29.40
	SDT	74.50	83.10	91.90	100.80	109.80	119.00	128.10	137.30
	KW	2.36	2.57	2.80	3.06	3.34	3.64	3.96	4.30
40	TCG	53.30	50.40	47.50	44.70	41.80	39.00	36.20	33.40
	SDT	76.50	85.00	93.70	102.50	111.50	120.50	129.60	138.80
	KW	2.39	2.61	2.85	3.11	3.41	3.73	4.07	4.44
45	TCG	58.90	55.80	52.70	49.60	46.60	43.60	40.70	37.70
	SDT	78.60	87.00	95.60	104.30	113.20	122.20	131.20	140.30
	KW	2.43	2.65	2.89	3.17	3.47	3.80	4.17	4.56
50	TCG	64.80	61.40	58.10	54.80	51.60	48.40	45.30	42.10
	SDT	80.80	89.10	97.50	106.10	115.00	123.90	132.90	141.90
	KW	2.47	2.69	2.94	3.22	3.53	3.88	4.26	4.67
55	TCG	71.00	67.30	63.80	60.20	56.80	53.40	50.10	46.70
	SDT	83.00	91.30	99.60	108.10	116.80	125.60	134.60	143.50
	KW	2.51	2.73	2.99	3.27	3.59	3.95	4.34	4.77
N2A360*HA, N2A360*LA, N2A360ASA									
30	TCG	52.70	50.20	47.70	45.00	42.30	39.50	36.50	33.50
	SDT	73.80	82.80	92.00	101.10	110.30	119.50	128.70	137.90
	KW	2.74	3.06	3.42	3.81	4.24	4.69	5.17	5.66
35	TCG	58.00	55.40	52.60	49.80	46.80	43.80	40.70	37.50
	SDT	75.60	84.50	93.60	102.70	111.80	120.90	130.10	139.20
	KW	2.76	3.09	3.45	3.85	4.28	4.75	5.24	5.75
40	TCG	63.70	60.80	57.80	54.80	51.70	48.50	45.20	41.80
	SDT	77.50	86.30	95.30	104.30	113.40	122.50	131.50	140.60
	KW	2.79	3.12	3.48	3.88	4.32	4.80	5.31	5.84
45	TCG	69.70	66.60	63.40	60.10	56.70	53.30	49.80	46.20
	SDT	79.40	88.20	97.10	106.00	115.00	124.00	133.10	142.10
	KW	2.82	3.15	3.51	3.92	4.37	4.85	5.37	5.92
50	TCG	76.00	72.70	69.20	65.70	62.10	58.40	54.60	50.70
	SDT	81.40	90.20	98.90	107.80	116.70	125.70	134.60	143.60
	KW	2.85	3.18	3.55	3.96	4.41	4.90	5.43	5.99
55	TCG	82.80	79.10	75.30	71.50	67.60	63.60	59.60	55.50
	SDT	83.50	92.20	100.90	109.60	118.50	127.30	136.20	145.10
	KW	2.88	3.22	3.59	4.00	4.46	4.95	5.49	6.06

TCG = Gross Cooling Capacity (x 1000 BTU/hr)

SDT = Saturated Temperature Leaving Compressor

kW = Outdoor Unit Kilowatts

COOLING Multiplying Factors for other Indoor Combinations

Indoor Model	Furnace Model	Capac. (MBh)	Power (AMPS)	Indoor Model	Furnace Model	Capac. (MBh)	Power (AMPS)	Indoor Model	Furnace Model	Capac. (MBh)	Power (AMPS)
N2A336											
>EB*2X36F**		1.00	1.00	EHD2X36A**	MV20N26****	1.04	0.99	EP*42J****		0.99	1.02
EB*2X36B**		0.97	0.97	EHD2X42A**		1.02	1.02	EP*42J****	*8MPV100	0.99	1.02
EB*2X36B**	MV08B15****	1.00	0.98	EHD2X42A**	*8MPV075	1.03	1.01	EP*42J****	*8MPV125	0.98	1.01
EB*2X36F**	*8MPV075	1.01	0.99	EHD2X42A**	*8MPV100	1.02	0.98	EP*42J****	*9MPV100	0.99	1.02
EB*2X36F**	MV12F19****	1.02	1.00	EHD2X42A**	*8MPV125	1.02	0.98	EP*42J****	MV16J22****	0.99	0.99
EB*2X36J**		1.00	1.00	EHD2X42A**	*9MPV075	1.02	1.01	EPP036****		0.90	0.92
EB*2X36J**	*8MPV100	1.01	0.99	EHD2X42A**	*9MPV100	1.02	0.98	EX*36B****		1.01	1.03
EB*2X36J**	*8MPV125	1.02	0.97	EHD2X42A**	*9MPV125	1.03	0.98	EX*36B****	*8MPV050	1.01	1.03
EB*2X36J**	*9MPV100	1.01	0.99	EHD2X42A**	MV08B15****	1.02	0.98	EX*36B****	MV08B15****	1.02	1.02
EB*2X36J**	MV16J22****	1.01	0.97	EHD2X42A**	MV12F19****	1.02	0.98	EX*36F****		1.01	1.03
EB*2X42J**		1.01	1.01	EHD2X42A**	MV16J22****	1.02	0.98	EX*36F****	*8MPV075	1.02	1.02
EB*2X42J**	*8MPV100	1.02	0.98	EHD2X42A**	MV20N26****	1.02	0.98	EX*36F****	*9MPV050	1.01	1.03
EB*2X42J**	*8MPV125	1.02	0.98	EL*36B****		0.95	0.97	EX*36F****	*9MPV075	1.01	1.04
EB*2X42J**	*9MPV100	1.02	1.00	EL*36B****	*8MPV050	0.95	0.98	EX*36F****	MV12F19****	1.02	1.01
EB*2X42J**	MV16J22****	1.02	0.97	EL*36B****	MV08B15****	0.97	1.00	EX*36J****		1.01	1.04
EB*2X42L**		1.01	1.01	EL*36F****		0.96	0.99	EX*36J****	*8MPV100	1.02	1.00
EB*2X42L**	*9MPV125	1.03	1.01	EL*36F****	*8MPV075	0.97	1.00	EX*36J****	*8MPV125	1.04	1.02
ED*2X36B**		0.98	0.98	EL*36F****	*9MPV050	0.96	0.99	EX*36J****	*9MPV100	1.02	1.00
ED*2X36B**	MV08B15****	0.99	0.98	EL*36F****	*9MPV075	0.96	0.99	EX*36J****	MV16J22****	1.04	1.00
ED*2X36F**		1.01	1.01	EL*36F****	MV12F19****	0.98	0.98	EX*42F****		1.02	1.02
ED*2X36F**	*8MPV075	1.02	1.00	EL*42F****		0.99	1.02	EX*42F****	*8MPV075	1.02	1.01
ED*2X36F**	MV12F19****	1.02	0.98	EL*42F****	*8MPV075	1.00	1.03	EX*42F****	*9MPV050	1.01	1.04
ED*2X36J**		1.01	1.01	EL*42F****	*9MPV050	0.99	1.02	EX*42F****	*9MPV075	1.02	1.02
ED*2X36J**	*8MPV100	1.02	0.97	EL*42F****	*9MPV075	0.99	1.02	EX*42F****	MV12F19****	1.03	0.98
ED*2X36J**	*8MPV125	1.02	0.98	EL*42F****	MV12F19****	1.00	1.00	EX*42J****		1.02	1.02
ED*2X36J**	*9MPV100	1.02	1.00	EMH36F****		0.96	0.99	EX*42J****	*8MPV100	1.04	1.02
ED*2X36J**	MV16J22****	1.02	0.97	EMH42F****		0.99	1.02	EX*42J****	*8MPV125	1.04	1.02
ED*2X42J**		1.02	1.02	EP*36B****		0.95	0.97	EX*42J****	*9MPV100	1.04	1.04
ED*2X42J**	*8MPV100	1.03	0.98	EP*36B****	*8MPV050	0.95	0.98	EX*42J****	MV16J22****	1.04	1.00
ED*2X42J**	*8MPV125	1.03	0.98	EP*36B****	MV08B15****	0.97	1.00	FSU2X36****		0.98	0.98
ED*2X42J**	*9MPV100	1.02	1.01	EP*36F****		0.96	0.99	FS(M,U)2X42***		1.01	1.01
ED*2X42J**	MV16J22****	1.02	0.98	EP*36F****	*8MPV075	0.97	1.00	FEM2X35****		1.01	0.99
ED*2X42L**		1.02	1.02	EP*36F****	*9MPV050	0.96	0.99	FSM2X36****		1.02	1.02
ED*2X42L**	*9MPV125	1.04	0.99	EP*36F****	*9MPV075	0.96	0.99	FEM2X36****		1.04	1.00

> Indicates Tested Indoor Model

- continued on next page -

COOLING Multiplying Factors for other Indoor Combinations (continued)

Indoor Model	Furnace Model	Capac. (MBh)	Power (AMPS)	Indoor Model	Furnace Model	Capac. (MBh)	Power (AMPS)	Indoor Model	Furnace Model	Capac. (MBh)	Power (AMPS)
EMA2X36D**		1.00	1.00	EP*36F****	MV12F19****	0.98	0.98	FEM2X42****		1.04	0.99
EHD2X36A**		1.01	1.01	EP*36J****		0.96	0.99	EBP36****		0.98	1.01
EHD2X36A**	*8MPV075	1.02	1.00	EP*36J****	*8MPV100	0.98	1.00	EBP42****		1.00	1.03
EHD2X36A**	*8MPV100	1.02	0.97	EP*36J****	*8MPV125	0.98	0.98	FSA2X36****		1.01	1.01
EHD2X36A**	*8MPV125	1.02	0.97	EP*36J****	*9MPV100	0.96	0.99	EBV36****		1.01	0.99
EHD2X36A**	*9MPV075	1.02	1.02	EP*36J****	MV16J22****	0.98	0.96	EBV48****		1.05	1.01
EHD2X36A**	*9MPV100	1.02	1.00	EP*42F****		0.99	1.02	EBX36****		1.00	1.03
EHD2X36A**	*9MPV125	1.02	0.98	EP*42F****	*8MPV075	1.00	1.03	FVM2X36****		1.01	0.92
EHD2X36A**	MV08B15****	1.02	0.97	EP*42F****	*9MPV050	0.99	1.02	FVM2X48****		1.05	0.96
EHD2X36A**	MV12F19****	1.02	0.98	EP*42F****	*9MPV075	0.99	1.02				
EHD2X36A**	MV16J22****	1.04	0.99	EP*42F****	MV12F19****	1.01	1.01				
N2A342											
>EB*2X42J**		1.00	1.00	EHD2X42A**	*8MPV075	1.00	1.00	EP*48J****		0.99	1.02
EB*2X42J**	*8MPV100	1.00	0.98	EHD2X42A**	*8MPV100	1.00	0.98	EP*48J****	*8MPV100	0.99	0.99
EB*2X42J**	*8MPV125	1.00	0.98	EHD2X42A**	*8MPV125	1.00	0.98	EP*48J****	*8MPV125	0.99	0.99
EB*2X42J**	*9MPV100	1.00	1.00	EHD2X42A**	*9MPV075	1.00	1.00	EP*48J****	*9MPV100	0.98	0.98
EB*2X42J**	MV16J22****	1.00	0.96	EHD2X42A**	*9MPV100	1.00	0.98	EP*48J****	MV16J22****	0.99	0.94
EB*2X42L**		1.00	1.00	EHD2X42A**	*9MPV125	1.00	0.98	EP*48L****		0.99	1.02
EB*2X42L**	*9MPV125	1.00	0.98	EHD2X42A**	MV16J22****	1.00	0.96	EP*48L****	*9MPV125	0.99	0.99
EB*2X48F**		1.00	1.00	EHD2X42A**	MV20N26****	1.00	0.96	EP*48N****		0.99	1.02
EB*2X48F**	*8MPV075	1.00	1.00	EHD2X48A**		0.99	0.99	EP*48N****	MV20N26****	0.99	0.97
EB*2X48F**	*9MPV075	0.99	0.99	EHD2X48A**	*8MPV075	0.99	0.99	EX*42F****		0.98	0.98
EB*2X48J**		1.01	1.01	EHD2X48A**	*8MPV100	0.99	0.97	EX*42F****	*8MPV075	0.99	0.99
EB*2X48J**	*8MPV100	1.01	0.99	EHD2X48A**	*8MPV125	0.99	0.97	EX*42F****	*9MPV075	0.98	0.98
EB*2X48J**	*8MPV125	1.01	0.97	EHD2X48A**	*9MPV075	0.99	0.99	EX*42J****		0.98	0.98
EB*2X48J**	*9MPV100	1.01	0.99	EHD2X48A**	*9MPV100	0.99	0.97	EX*42J****	*8MPV100	1.00	1.00
EB*2X48J**	MV16J22****	1.02	0.98	EHD2X48A**	*9MPV125	0.99	0.97	EX*42J****	*8MPV125	1.00	0.98
EB*2X48L**		1.01	1.01	EHD2X48A**	MV16J22****	0.99	0.94	EX*42J****	*9MPV100	0.99	0.99
EB*2X48L**	*9MPV125	1.02	1.01	EHD2X48A**	MV20N26****	0.99	0.94	EX*42J****	MV16J22****	1.01	0.99
ED*2X42J**		1.00	1.00	EL*42F****		0.94	0.96	EX*48J****		1.00	1.00
ED*2X42J**	*8MPV100	1.00	0.98	EL*42F****	*8MPV075	0.95	0.98	EX*48J****	*9MPV125	1.00	0.98
ED*2X42J**	*8MPV125	1.00	0.98	EL*42F****	*9MPV075	0.94	0.96	EX*48L****		1.00	1.00
ED*2X42J**	*9MPV100	1.00	1.00	EL*48F****		0.96	0.99	EX*48L****	*9MPV125	1.00	1.00
ED*2X42J**	MV16J22****	1.00	0.96	EL*48F****	*8MPV075	0.96	0.99	EX*48N****		1.00	1.00
ED*2X42L**		1.00	1.00	EL*48F****	*9MPV075	0.95	0.98	EX*48N****	MV20N26****	1.00	0.96

> Indicates Tested Indoor Model

- continued on next page -

COOLING Multiplying Factors for other Indoor Combinations (continued)

Indoor Model	Furnace Model	Capac. (MBh)	Power (AMPS)	Indoor Model	Furnace Model	Capac. (MBh)	Power (AMPS)	Indoor Model	Furnace Model	Capac. (MBh)	Power (AMPS)
ED*2X42L**	*9MPV125	1.00	0.98	EMH42F****		0.94	0.96	FS(M,U)2X42***		1.00	1.00
ED*2X48F**		1.00	1.00	EMH48F****		0.98	1.00	FS(M,U)2X48***		1.01	1.01
ED*2X48F**	*8MPV075	1.00	1.00	EP*42F****		0.94	0.96	FEM2X42****		1.02	1.01
ED*2X48F**	*9MPV075	0.99	0.99	EP*42F****	*8MPV075	0.95	0.98	FEM2X48****		1.04	0.99
ED*2X48J**		1.01	1.01	EP*42F****	*9MPV075	0.94	0.96	EBP42****		0.98	1.00
ED*2X48J**	*8MPV100	1.01	0.99	EP*42J****		0.95	0.98	EBP48****		1.00	1.03
ED*2X48J**	*8MPV125	1.02	1.01	EP*42J****	*8MPV100	0.95	0.98	EBV36****		0.98	0.96
ED*2X48J**	*9MPV100	1.01	0.99	EP*42J****	*8MPV125	0.95	0.98	EBV48****		1.04	0.99
ED*2X48J**	MV16J22****	1.02	0.98	EP*42J****	*9MPV100	0.94	0.96	EBV60****		1.06	1.02
ED*2X48L**		1.01	1.01	EP*42J****	MV16J22****	0.95	0.95	EBX48****		1.01	1.01
ED*2X48L**	*9MPV125	1.02	1.01	EP*48F****		0.96	0.99	FVM2X48****		1.04	0.95
EMA2X48D**		0.99	0.99	EP*48F****	*8MPV075	0.96	0.99	FVM2X60****		1.04	0.95
EHD2X42A**		1.00	1.00	EP*48F****	*9MPV075	0.95	0.98				
N2A348											
>EB*2X48J**		1.00	1.00	ED*2X60J**	MV16J22****	1.05	1.01	EP*60J****		0.99	1.02
EB*2X48F**		0.98	0.98	ED*2X60L**		1.03	1.03	EP*60J****	MV16J22****	1.00	0.98
EB*2X48J**	*8MPV100	1.00	1.00	ED*2X60L**	*9MPV125	1.03	1.01	EP*60L****		0.99	1.02
EB*2X48J**	*8MPV125	1.01	1.01	EMA2X48D**		0.98	0.98	EP*60N****		0.99	1.02
EB*2X48J**	*9MPV100	0.98	0.98	EHD2X48A**		1.00	1.00	EP*60N****	MV20N26****	1.00	0.98
EB*2X48J**	MV16J22****	1.02	1.00	EHD2X48A**	*8MPV100	0.99	0.97	EX*48J****		0.98	1.01
EB*2X48L**		1.00	1.00	EHD2X48A**	*8MPV125	0.99	0.99	EX*48L****		0.98	1.01
EB*2X48L**	*9MPV125	1.00	1.00	EHD2X48A**	*9MPV100	0.99	0.99	EX*48N****		0.98	1.01
EB*2X60J**		1.03	1.03	EHD2X48A**	*9MPV125	0.99	0.99	EX*48N****	MV20N26****	1.00	0.98
EB*2X60J**	*8MPV100	1.04	1.04	EHD2X48A**	MV16J22****	0.99	0.97	EX*60L****		1.04	1.04
EB*2X60J**	*8MPV125	1.04	1.02	EHD2X48A**	MV20N26****	0.99	0.97	EX*60L****	*9MPV125	1.03	1.01
EB*2X60J**	*9MPV100	1.03	1.03	EHD2X60A**		1.03	1.03	EX*60N****		1.04	1.04
EB*2X60J**	MV16J22****	1.05	1.01	EHD2X60A**	*8MPV100	1.02	1.00	EX*60N****	MV20N26****	1.05	1.01
EB*2X60L**		1.03	1.03	EHD2X60A**	*8MPV125	1.02	1.00	FS(M,U)2X48***		1.02	1.02
EB*2X60L**	*9MPV125	1.03	1.01	EHD2X60A**	*9MPV100	1.02	1.02	FS(M,U)2X60***		1.04	1.04
ED*2X48F**		0.98	0.98	EHD2X60A**	*9MPV125	1.02	1.00	FEM2X48****		1.03	1.01
ED*2X48J**		1.00	1.00	EHD2X60A**	MV16J22****	1.02	0.98	FEM2X60****		1.05	1.01
ED*2X48J**	*8MPV100	1.00	1.00	EHD2X60A**	MV20N26****	1.02	0.98	EBP48****		1.00	1.03
ED*2X48J**	*8MPV125	1.01	1.01	EL*48F****		0.93	0.96	EBP60****		1.02	1.05
ED*2X48L**	*9MPV100	0.98	0.98	EL*60J****		0.99	1.02	EBV48****		1.03	1.01

> Indicates Tested Indoor Model

- continued on next page -

COOLING Multiplying Factors for other Indoor Combinations (continued)											
Indoor Model	Furnace Model	Capac. (MBh)	Power (AMPS)	Indoor Model	Furnace Model	Capac. (MBh)	Power (AMPS)	Indoor Model	Furnace Model	Capac. (MBh)	Power (AMPS)
ED*2X48J**	MV16J22****	1.02	1.00	EL*60J****	MV16J22****	1.00	0.98	EBV60****		1.05	1.01
ED*2X48L**		1.00	1.00	EMH48F****		0.95	0.97	EBX48****		1.02	1.05
ED*2X48L**	*9MPV125	1.00	1.00	EP*48F****		0.93	0.96	EBX60****		1.04	1.07
ED*2X60J**		1.03	1.03	EP*48J****		0.96	0.98	FVM2X48****		1.02	0.94
ED*2X60J**	*8MPV100	1.04	1.04	EP*48L****		0.96	0.98	FVM2X60****		1.03	0.95
ED*2X60J**	*8MPV125	1.04	1.04	EP*48N****		0.96	0.98				
ED*2X60J**	*9MPV100	1.03	1.03	EP*48N****	MV20N26****	0.98	0.98				
N2A360											
>EB*2X60L**		1.00	1.00	EHD2X60A**	*8MPV100	0.96	0.96	EX*60N****		0.99	1.02
EB*2X60J**		0.98	0.98	EHD2X60A**	*8MPV125	0.96	0.96	EX*60N****	MV20N26****	1.00	1.00
EB*2X60J**	*8MPV125	0.97	0.97	EHD2X60A**	MV16J22****	0.97	0.97	FS(M,U)2X60***		0.99	0.99
EB*2X60J**	MV16J22****	1.00	1.00	EHD2X60A**	MV20N26****	0.97	0.96	FEM2X60****		1.01	1.01
ED*2X60J**		0.98	0.98	EL*60J****		0.93	0.97	EBP60****		0.98	1.04
ED*2X60J**	*8MPV125	0.97	0.97	EP*60J****		0.93	0.97	EBV60****		0.99	0.99
ED*2X60J**	MV16J22****	1.00	1.00	EP*60L****		0.93	0.97	EBX60****		1.00	1.03
ED*2X60L**		1.00	1.00	EP*60N****		0.93	0.97	FVM2X60****		1.00	0.98
EHD2X60A**		0.98	0.98	EX*60L****		0.99	1.02				

> Indicates Tested Indoor Model

NOTE: This illustration is for reference only. Your unit may differ in appearance or may not include all components shown. Please refer to Parts List for exact parts listing.

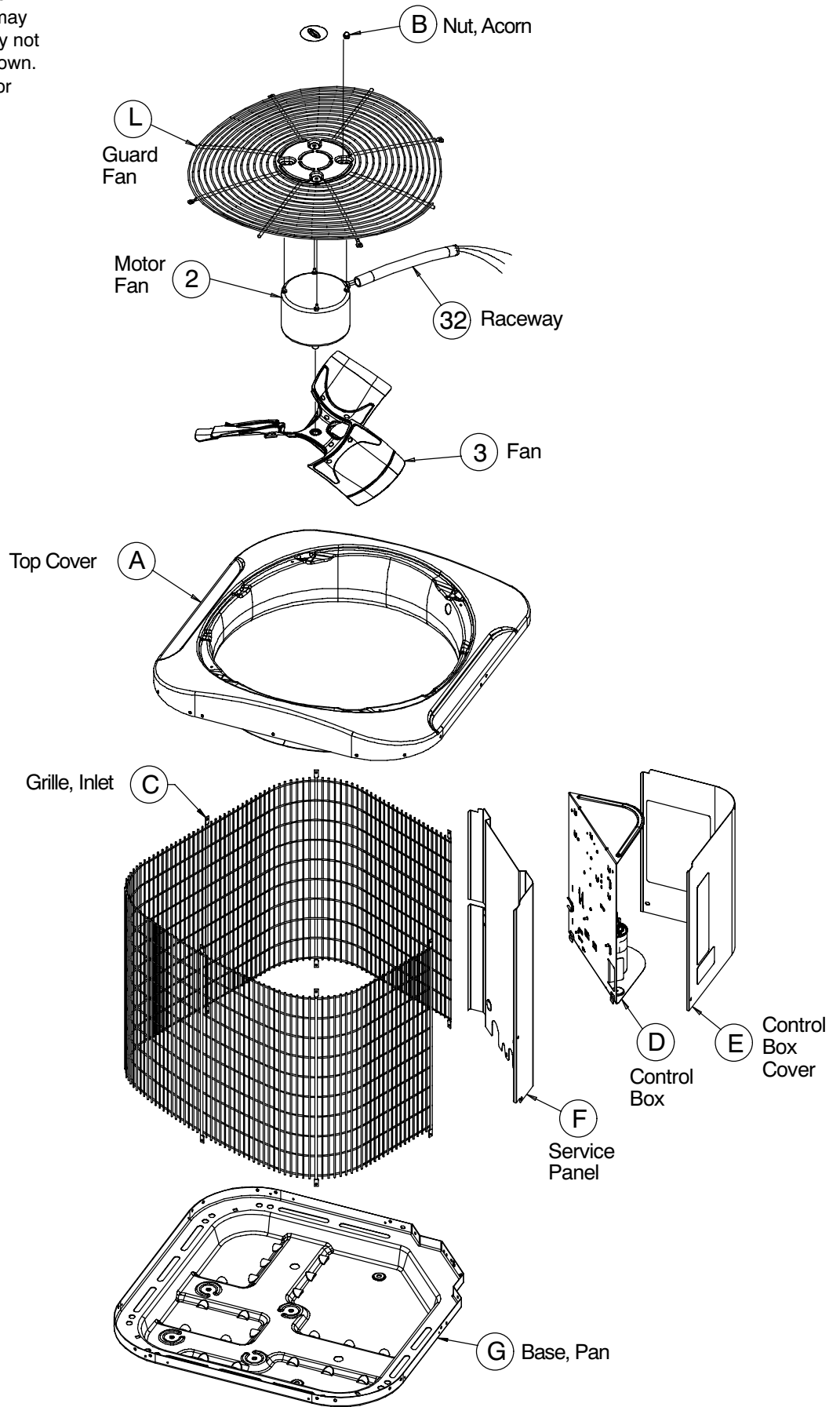

NOTE: This illustration is for reference only. Your unit may differ in appearance or may not include all components shown. Please refer to Parts List for exact parts listing.

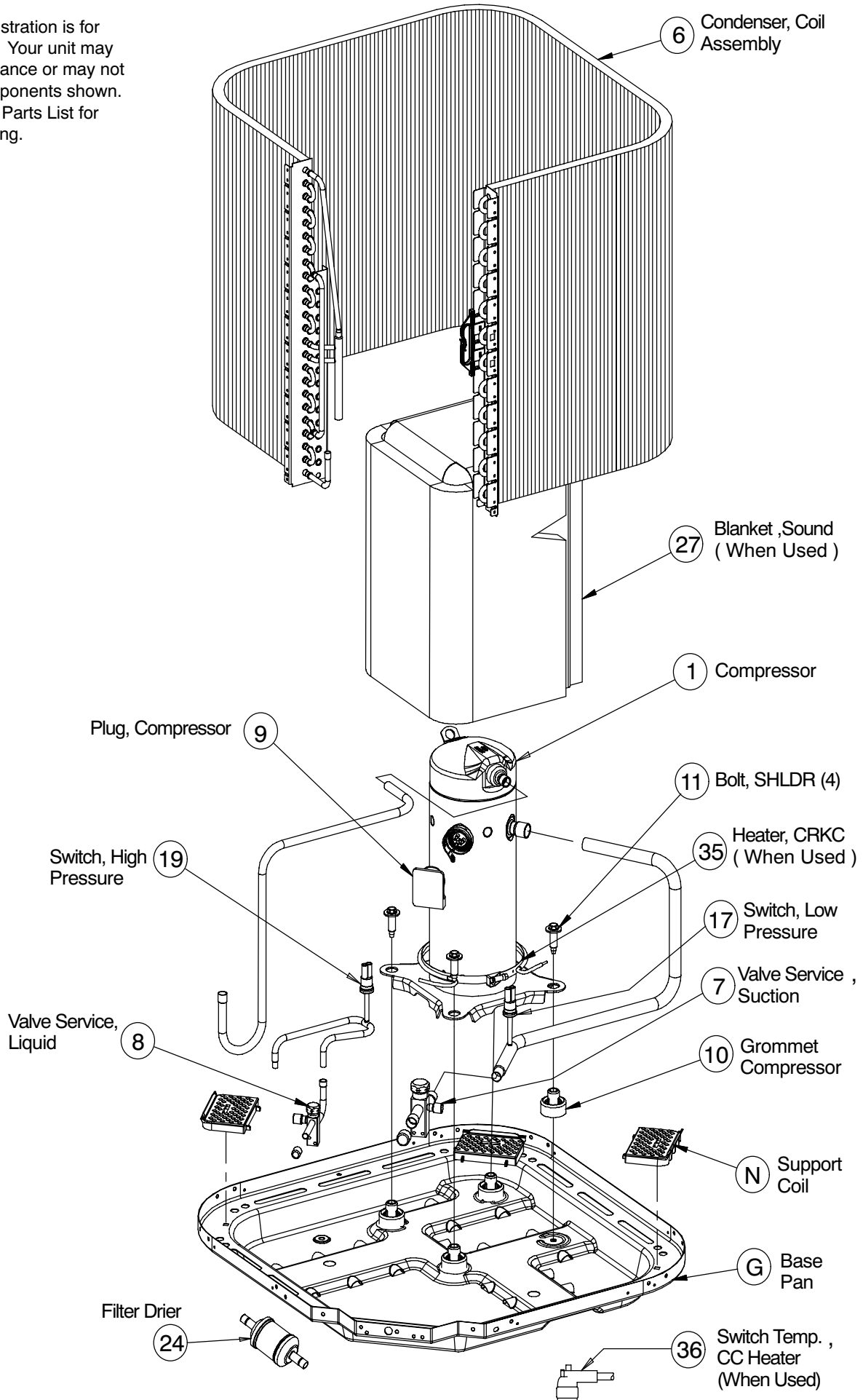

208/230, 460 Volt

NOTE: This illustration is for reference only. Your unit may differ in appearance or may not include all components shown.

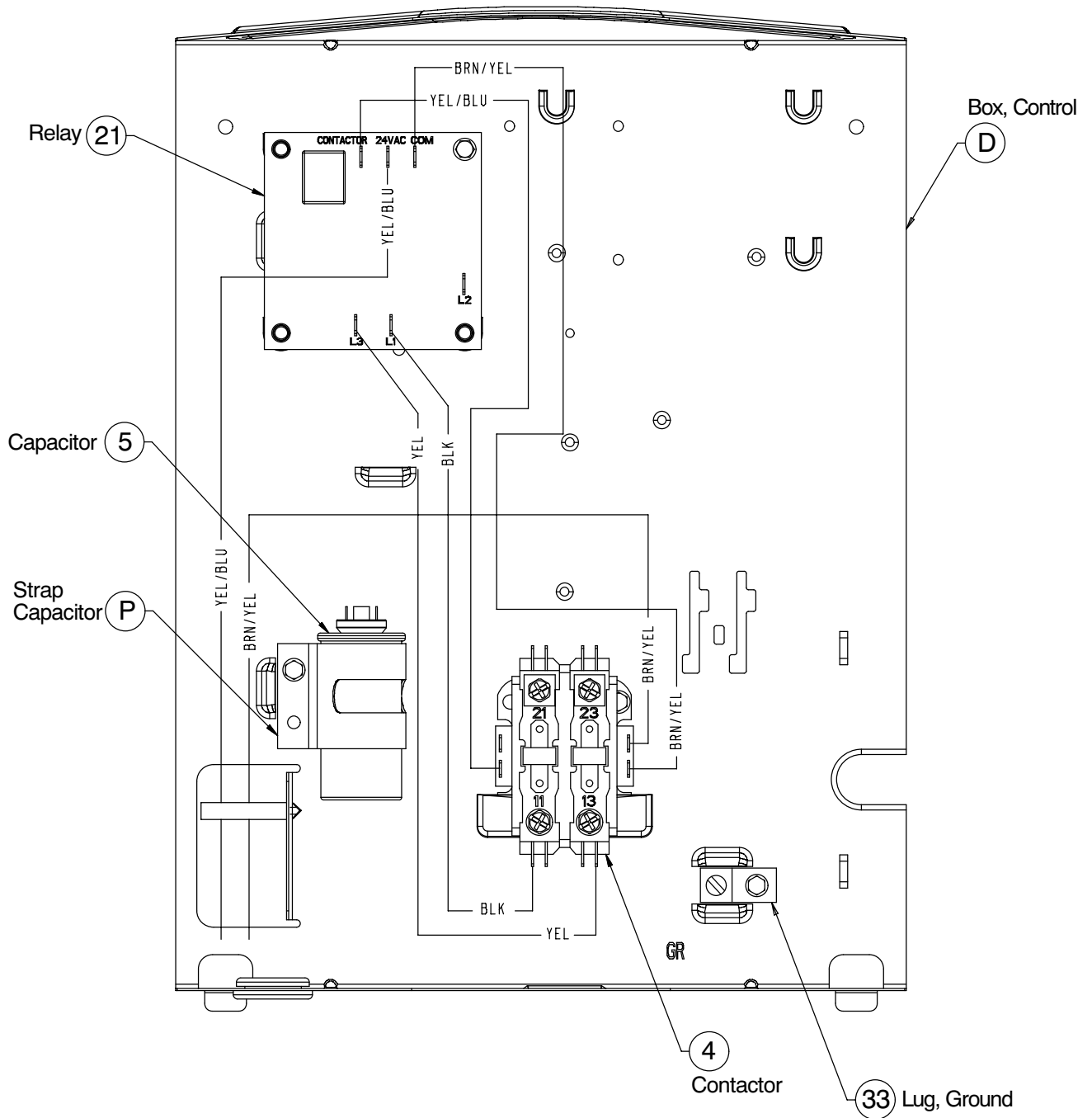

575 Volt

NOTE: This illustration is for reference only. Your unit may differ in appearance or may not include all components shown.

BOX CONTROL

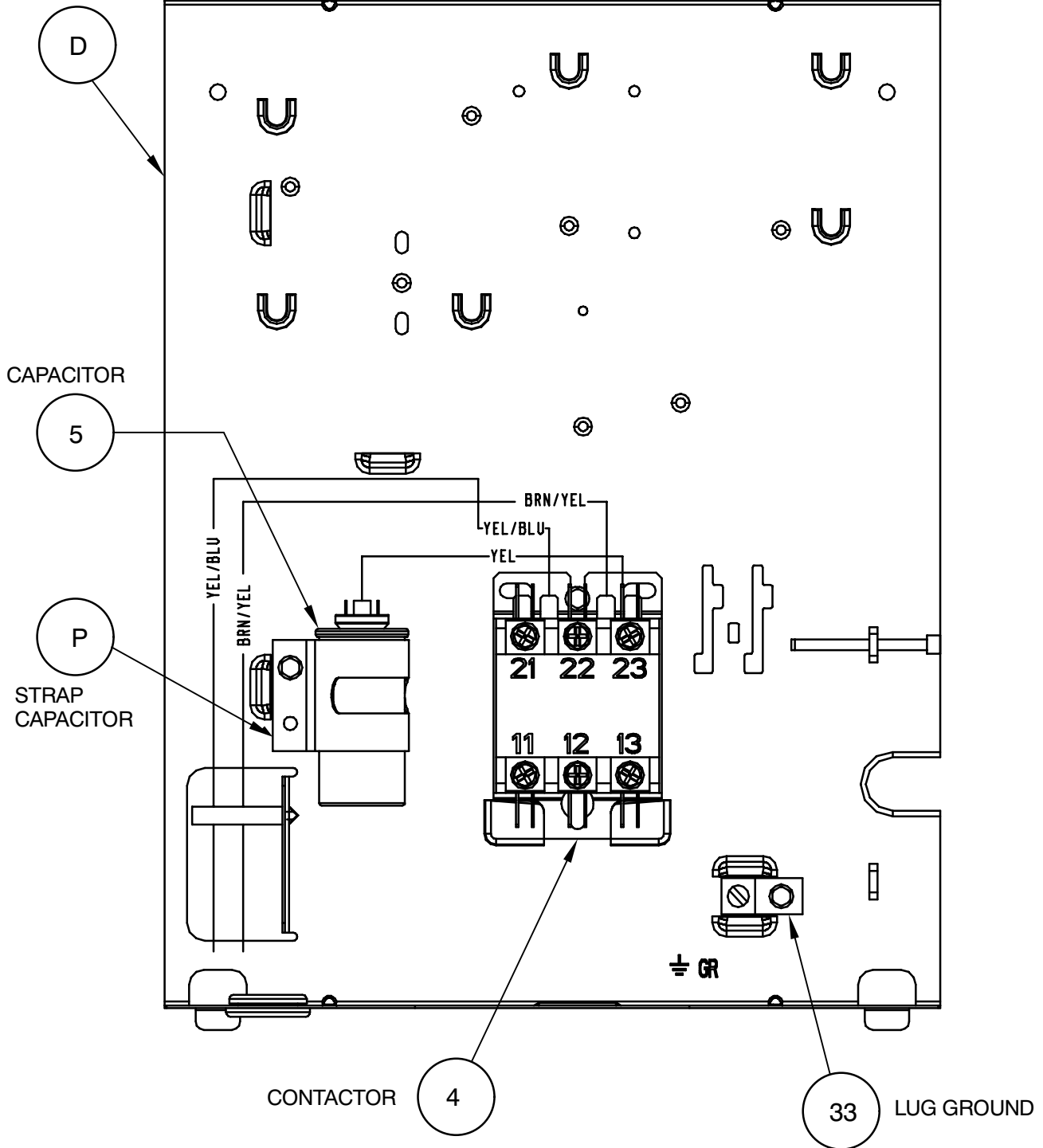

N2A3 PARTS LIST																						
KEY NO.	DESCRIPTION	PART NO.	N2A336AHA200	N2A336GHA200	N2A336ALA200	N2A336GLA200	N2A336ASA100	N2A342AHA100	N2A342GHA100	N2A342ALA100	N2A342GLA100	N2A348AHA200	N2A348GHA200	N2A348ALA200	N2A348GLA200	N2A348ASA100	N2A360AHA200	N2A360GHA200	N2A360ALA200	N2A360GLA200	N2A360ASA100	
1	Compressor	ZR32KATF5130	1	1	-	-	-	-	-	-	-	-	-	-	-	-	-	-	-	-	-	-
1		ZR32KATFD130	-	-	1	1	-	-	-	-	-	-	-	-	-	-	-	-	-	-	-	-
1		ZR32KATFE130	-	-	-	-	1	-	-	-	-	-	-	-	-	-	-	-	-	-	-	-
1		ZR38KATF5130	-	-	-	-	-	1	1	-	-	-	-	-	-	-	-	-	-	-	-	-
1		ZR38KATFD130	-	-	-	-	-	-	-	1	1	-	-	-	-	-	-	-	-	-	-	-
1		ZR44KATF5130	-	-	-	-	-	-	-	-	-	1	1	-	-	-	-	-	-	-	-	-
1		ZR44KATFD130	-	-	-	-	-	-	-	-	-	-	-	1	1	-	-	-	-	-	-	-
1		ZR44KATFE130	-	-	-	-	-	-	-	-	-	-	-	-	-	1	-	-	-	-	-	-
1		ZR54KATF5130	-	-	-	-	-	-	-	-	-	-	-	-	-	-	1	1	-	-	-	-
1		ZR54KATFD130	-	-	-	-	-	-	-	-	-	-	-	-	-	-	-	-	1	1	-	-
1		ZR54KATFE130	-	-	-	-	-	-	-	-	-	-	-	-	-	-	-	-	-	-	-	1
2	Motor, Condenser Fan	1172775	1	1	-	-	-	-	-	-	-	-	-	-	-	-	-	-	-	-	-	-
2		1173778	-	-	1	1	-	-	-	-	-	-	-	-	-	-	-	-	-	-	-	-
2		1172709	-	-	-	-	-	1	1	-	-	-	-	-	-	-	-	-	-	-	-	-
2		1172780	-	-	-	-	-	-	-	1	1	-	-	-	-	-	-	-	-	-	-	-
2		1173665	-	-	-	-	-	-	-	-	-	1	1	-	-	-	1	1	-	-	-	-
2		1173781	-	-	-	-	-	-	-	-	-	-	-	1	1	-	-	-	1	1	-	-
2		1174999	-	-	-	-	1	-	-	-	-	-	-	-	-	-	-	-	-	-	-	-
2		1175001	-	-	-	-	-	-	-	-	-	-	-	-	-	1	-	-	-	-	-	1
3	Fan Blade	1172713	1	1	1	1	1	-	-	-	-	-	-	-	-	-	-	-	-	-	-	-
3		1173854	-	-	-	-	-	1	1	1	1	-	-	-	-	-	-	-	-	-	-	-
3		1172716	-	-	-	-	-	-	-	-	-	1	1	1	1	1	1	1	1	1	1	1
4	Contact, 25 Amp	1175002	-	-	-	-	1	-	-	-	-	-	-	-	-	1	-	-	-	-	-	1
4	Contact, 30 Amp	1173785	1	1	1	1	-	1	1	1	1	1	1	1	1	-	-	-	-	-	-	-
4	30 Amp	1173786	-	-	-	-	-	-	-	-	-	-	-	-	-	-	1	1	1	1	1	-
5	Capacitor 370V 5 Mfd	1171727	1	1	1	1	1	1	1	1	1	-	-	1	1	1	-	-	1	1	1	1
5	370V 7.5 Mfd	1171728	-	-	-	-	-	-	-	-	-	1	1	-	-	-	1	1	-	-	-	-
6	Condenser Coil	1174074	1	1	1	1	1	-	-	-	-	-	-	-	-	-	-	-	-	-	-	-
6		1172789	-	-	-	-	-	1	1	1	1	-	-	-	-	-	-	-	-	-	-	-
6		1174078	-	-	-	-	-	-	-	-	-	1	1	1	1	1	-	-	-	-	-	-
6		1174083	-	-	-	-	-	-	-	-	-	-	-	-	-	-	1	1	1	1	1	1
7	Service Valve, Suction	1172726	1	1	1	1	1	-	-	-	-	-	-	-	-	-	-	-	-	-	-	-
7		1172727	-	-	-	-	-	1	1	1	1	1	1	1	1	1	1	1	1	1	1	1
8	Service Valve, Liquid	1172792	1	1	1	1	-	1	1	1	1	1	1	1	1	-	1	1	1	1	1	-
9	Plug, Compressor Harness	1174072	1	1	1	1	-	1	1	1	1	-	-	-	-	-	-	-	-	-	-	-
9		1174082	-	-	-	-	-	-	-	-	-	1	1	1	1	-	1	1	1	1	1	-
9		1174827	-	-	-	-	1	-	-	-	-	-	-	-	-	-	-	-	-	-	-	-
9		1174828	-	-	-	-	-	-	-	-	-	-	-	-	-	-	1	-	-	-	-	1
10	Grommet, Compressor	1171270	4	4	4	4	4	4	4	4	4	4	4	4	4	4	4	4	4	4	4	4
11	Bolt, Compressor Mounting	1173630	4	4	4	4	4	4	4	4	4	4	4	4	4	4	4	4	4	4	4	4
20	Distributor	1172021	-	-	-	-	-	1	1	1	1	-	-	-	-	-	-	-	-	-	-	-
20		1172022	-	-	-	-	-	-	-	-	-	1	1	1	1	-	-	-	-	-	-	-
20		1173667	-	-	-	-	-	-	-	-	-	-	-	-	-	-	1	1	1	1	1	-
21	Relay, Phase Monitor	1173408	1	1	1	1	-	1	1	1	1	1	1	1	1	-	1	1	1	1	1	-
24	Drier	1172795	1	1	1	1	1	-	-	-	-	-	-	-	-	-	-	-	-	-	-	-
24		1172794	-	-	-	-	-	1	1	1	1	1	1	1	1	1	1	1	1	1	1	1
32	Raceway	1173651	1	1	1	1	-	1	1	1	1	-	-	-	-	-	-	-	-	-	-	-
32		1173661	-	-	-	-	1	-	-	-	-	-	-	-	-	-	-	-	-	-	-	-
32		1173664	-	-	-	-	-	-	-	-	-	1	1	1	1	1	1	1	1	1	1	1
33	Lug, Ground	1172300	1	1	1	1	1	1	1	1	1	1	1	1	1	1	1	1	1	1	1	1
35	Heater, Crankcase	1173944	-	-	-	-	-	-	-	-	-	-	-	-	-	-	1	1	-	-	-	-
35		1174086	-	-	-	-	-	-	-	-	-	-	-	-	-	-	-	-	1	1	-	-
35		1175003	-	-	-	-	-	-	-	-	-	-	-	-	-	-	-	-	-	-	-	1
36	Switch, Temp. CC Htr	1173669	-	-	-	-	-	-	-	-	-	-	-	-	-	-	1	1	1	1	1	-
)	Harness, Wire Asy.	1172736	1	1	1	1	1	1	1	1	1	1	1	1	1	1	1	1	1	1	1	1

- continued on next page -

N2A3 PARTS LIST (continued)																					
KEY NO.	DESCRIPTION	PART NO.	N2A336AHA200	N2A336GHA200	N2A336ALA200	N2A336GLA200	N2A336ASA100	N2A342AHA100	N2A342GHA100	N2A342ALA100	N2A342GLA100	N2A348AHA200	N2A348GHA200	N2A348ALA200	N2A348GLA200	N2A348ASA100	N2A360AHA200	N2A360GHA200	N2A360ALA200	N2A360GLA200	N2A360ASA100
A	Panel, Top	1174075	1	1	1	1	1	1	1	1	1	-	-	-	-	-	-	-	-	-	-
A		1174079	-	-	-	-	-	-	-	-	-	1	1	1	1	1	1	1	1	1	1
B	Nut, Hex	1172740	4	4	4	4	4	4	4	4	4	4	4	4	4	4	4	4	4	4	4
C	Grille, Inlet	1173652	1	-	1	-	1	-	-	-	-	-	-	-	-	-	-	-	-	-	-
C		1173653	-	1	-	1	-	-	-	-	-	-	-	-	-	-	-	-	-	-	-
C		1172745	-	-	-	-	-	1	-	1	-	-	-	-	-	-	-	-	-	-	-
C		1172751	-	-	-	-	-	-	1	-	1	-	-	-	-	-	-	-	-	-	-
C		1173674	-	-	-	-	-	-	-	-	-	1	-	1	-	1	-	-	-	-	-
C		1173675	-	-	-	-	-	-	-	-	-	-	1	-	1	-	-	-	-	-	-
C		1174084	-	-	-	-	-	-	-	-	-	-	-	-	-	-	1	-	1	-	1
C		1174088	-	-	-	-	-	-	-	-	-	-	-	-	-	-	-	1	-	1	-
D	Box, Control	1172753	1	1	1	1	1	1	1	1	1	1	1	1	1	1	1	1	1	1	1
E	Cover, Control Box	1174065	1	1	1	1	-	1	1	1	1	1	1	1	1	-	1	1	1	1	1
E		1174995	-	-	-	-	1	-	-	-	-	-	-	-	-	-	-	-	-	-	-
E		1174997	-	-	-	-	-	-	-	-	-	-	-	-	-	1	-	-	-	-	-
E		1174998	-	-	-	-	-	-	-	-	-	-	-	-	-	-	-	-	-	-	1
F	Panel, Service	1174066	1	1	1	1	1	-	-	-	-	-	-	-	-	-	-	-	-	-	-
F		1174077	-	-	-	-	-	1	1	1	1	-	-	-	-	-	-	-	-	-	-
F		1174780	-	-	-	-	-	-	-	-	-	1	1	1	1	1	-	-	-	-	-
F		1174085	-	-	-	-	-	-	-	-	-	-	-	-	-	-	1	1	1	1	1
G	Pan, Base	1174076	1	1	1	1	1	1	1	1	1	-	-	-	-	-	-	-	-	-	-
G		1174081	-	-	-	-	-	-	-	-	-	1	1	1	1	1	1	1	1	1	1
L	Guard, Fan	1172764	1	1	1	1	1	1	1	1	1	-	-	-	-	-	-	-	-	-	-
L		1172765	-	-	-	-	-	-	-	-	-	1	1	1	1	1	1	1	1	1	1
N	Support, Coil	1174068	5	5	5	5	5	5	5	5	5	5	5	5	5	5	5	5	5	5	5
P	Strap, Capacitor	1174073	1	1	1	1	1	1	1	1	1	1	1	1	1	1	1	1	1	1	1
)	Screw, Gray Hex 10AB 3/8	1174676	14	14	14	14	14	14	14	14	14	14	14	14	14	14	14	14	14	14	14
)	Screw, Gray Hex 10AB 1/2	1174677	12	12	12	12	12	12	12	12	12	12	12	12	12	12	12	12	12	12	12
)	Screw, Gray Hex 12AB 5/8	1174678	4	4	4	4	4	4	4	4	4	4	4	4	4	4	4	4	4	4	4
)	Manual, Installation	50101500200	1	1	1	1	1	1	1	1	1	1	1	1	1	1	1	1	1	1	1
)	Manual, Owners	42102500000	1	1	1	1	1	1	1	1	1	1	1	1	1	1	1	1	1	1	1
)	Warranty	40106403403	1	1	1	1	1	1	1	1	1	1	1	1	1	1	1	1	1	1	1

OUTDOOR UNIT MODEL NUMBER IDENTIFICATION GUIDE (3-Phase)											
Digit Position:	1	2	3	4	5, 6	7	8	9	10	11	12
Example Part Number:	N	2	A	3	36	A	H	A	1	0	0
Product Family	BRANDING										
2 = R-22	REFRIGERANT										
A = Air Conditioner											
H = Heat Pump			TYPE								
3 = 13 SEER			NOMINAL EFFICIENCY								
36 = 36,000 BTUH = 3 tons											
42 = 42,000 BTUH = 3½ tons											
48 = 48,000 BTUH = 4 tons											
60 = 60,000 BTUH = 5 tons					NOMINAL CAPACITY						
A = Standard Grille											
G = Coil Guard Grille											
C = Coastal							FEATURES				
H = 208/230-3-60											
L = 460-3-60											
S = 575-3-60							VOLTAGE				
Sales Code											
Engineering Revision											
Extra Digit											
Extra Digit											

ACCESSORIES PART NUMBER IDENTIFICATION GUIDE									
Digit Position:	1	2	3	4	5	6, 7	8, 9	10, 11	
Example Part Number:	N	A	S	A	0	01	01	CH	
N = Non-Branded	BRANDING								
A = Accessory	PRODUCT GROUP								
S = Split System (AC & HP)			KIT USAGE						
A = Original									
B = 2nd Generation			MAJOR SERIES						
0 = Generic or Not Applicable									
2 = R-22									
4 = R-410A					REFRIGERANT				
Product Identifier Number									
Package Quantity									
Type of Kit (Example: CH = Crankcase Heater)									