

TECHNICAL SUPPORT MANUAL

Split System Heat Pump

H4H3, 3-Phase

Safety Labeling and Signal Words

DANGER, WARNING, CAUTION, and NOTE

The signal words **DANGER**, **WARNING**, **CAUTION**, and **NOTE** are used to identify levels of hazard seriousness. The signal word **DANGER** is only used on product labels to signify an immediate hazard. The signal words **WARNING**, **CAUTION**, and **NOTE** will be used on product labels and throughout this manual and other manuals that may apply to the product.

DANGER – Immediate hazards which **will** result in severe personal injury or death.

WARNING – Hazards or unsafe practices which **could** result in severe personal injury or death.

CAUTION – Hazards or unsafe practices which **may** result in minor personal injury or product or property damage.

NOTE – Used to highlight suggestions which **will** result in enhanced installation, reliability, or operation.

Signal Words in Manuals

The signal word **WARNING** is used throughout this manual in the following manner:



The signal word **CAUTION** is used throughout this manual in the following manner:



Signal Words on Product Labeling

Signal words are used in combination with colors and/or pictures on product labels.

TABLE OF CONTENTS

Model Number Identification	2
Wiring Diagrams	3 – 6
Charging Chart	7
Tech Labels (Expanded Data)	8 – 13
Cooling Multiplying Factors	14 – 18
Heating Multiplying Factors	19 – 23
Exploded View	24 – 27
Parts List	28 – 30

MODELS

- H4H330GHE100
- H4H336GHE100
- H4H336GLE100
- H4H342GHE100
- H4H348GHE100
- H4H348GLE100
- H4H360GHD200
- H4H360GLD200



DEATH, PERSONAL INJURY, AND/OR PROPERTY DAMAGE HAZARD

Failure to carefully read and follow this warning could result in equipment malfunction, property damage, personal injury and/or death.

Installation or repairs made by unqualified persons could result in equipment malfunction, property damage, personal injury and/or death.

The information contained in this manual is intended for use by a qualified service technician familiar with safety procedures and equipped with the proper tools and test instruments.

Installation must conform with local building codes and with the National Electrical Code NFPA70 current edition or Canadian Electrical Code Part 1 CSA C.22.1.

OUTDOOR UNIT MODEL NUMBER IDENTIFICATION GUIDE (3-Phase)											
Digit Position:	1	2	3	4	5, 6	7	8	9	10	11	12
Example Part Number:	H	4	H	3	30	G	H	E	1	0	0
Product Family											
2 = R-22											
4 = R-410A REFRIGERANT											
A = Air Conditioner											
H = Heat Pump TYPE											
3 = 13 SEER NOMINAL EFFICIENCY											
30 = 30,000 BTUH = 2½ tons											
36 = 36,000 BTUH = 3 tons NOMINAL CAPACITY											
42 = 42,000 BTUH = 3½ tons											
48 = 48,000 BTUH = 4 tons											
60 = 60,000 BTUH = 5 tons											
A = Standard Grille											
G = Coil Guard Grille FEATURES											
H = 208/230-3-60											
L = 460-3-60 VOLTAGE											
Sales Code											
Engineering Revision											
Extra Digit											
Extra Digit											

ACCESSORIES PART NUMBER IDENTIFICATION GUIDE									
Digit Position:	1	2	3	4	5	6, 7	8, 9	10, 11	
Example Part Number:	N	A	S	A	0	01	01	CH	
N = Non-Branded BRANDING									
A = Accessory PRODUCT GROUP									
S = Split System (AC & HP) KIT USAGE									
A = Original									
B = 2nd Generation MAJOR SERIES									
0 = Generic or Not Applicable									
2 = R-22									
4 = R-410A REFRIGERANT									
Product Identifier Number									
Package Quantity									
Type of Kit (Example: CH = Crankcase Heater)									

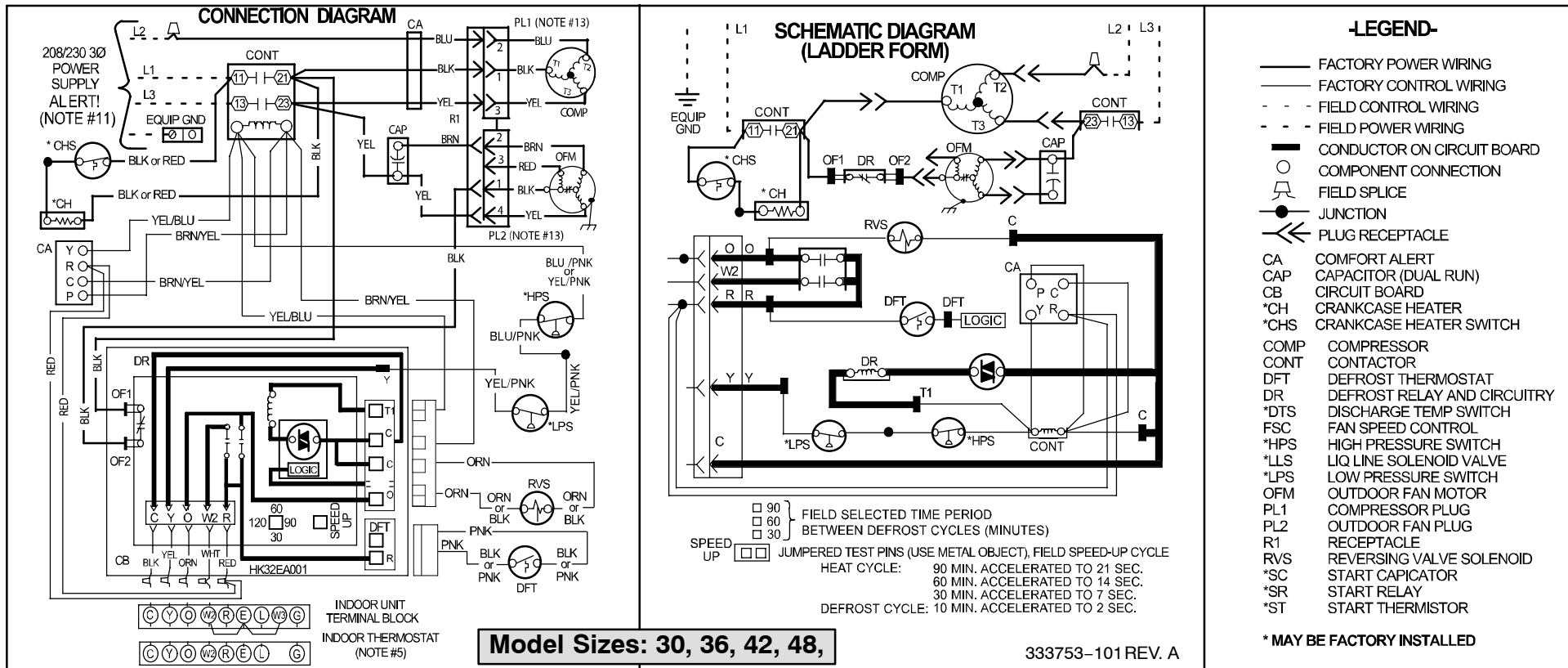

1. Symbols are electrical representation only.
2. Compressor and fan motor furnished with inherent thermal protection.
3. To be wired in accordance with National Electric N.E.C. and local codes.
4. N.E.C. class 2, 24 V circuit, min. 40 VA required, 60 VA on units installed with LLS.
5. Connection for typical heat pump thermostat. For other arrangements see installation instructions.
6. Use copper conductors only. Use conductors suitable for at least 75°C (167°F).
7. If indoor section has a transformer with a grounded secondary, connect the grounded side to "C" on the circuit board.
8. When start capacitor and relay are installed, start thermistor (PTC) is not used.
9. CH not used on all units.
10. If any of the original wire, as supplied, must be replaced, use the same or equivalent wire.
11. Check all electrical connections inside control box for tightness.
12. Do not attempt to operate unit until service valves have been opened.
13. Do not rapid cycle compressor. Compressor must be off 3 minutes to allow pressures to equalize between high and low side before starting.
14. It is imperative to connect 3-phase field power to unit with correct phasing. If phasing is reversed, interchange any two of the three power connections on field side.

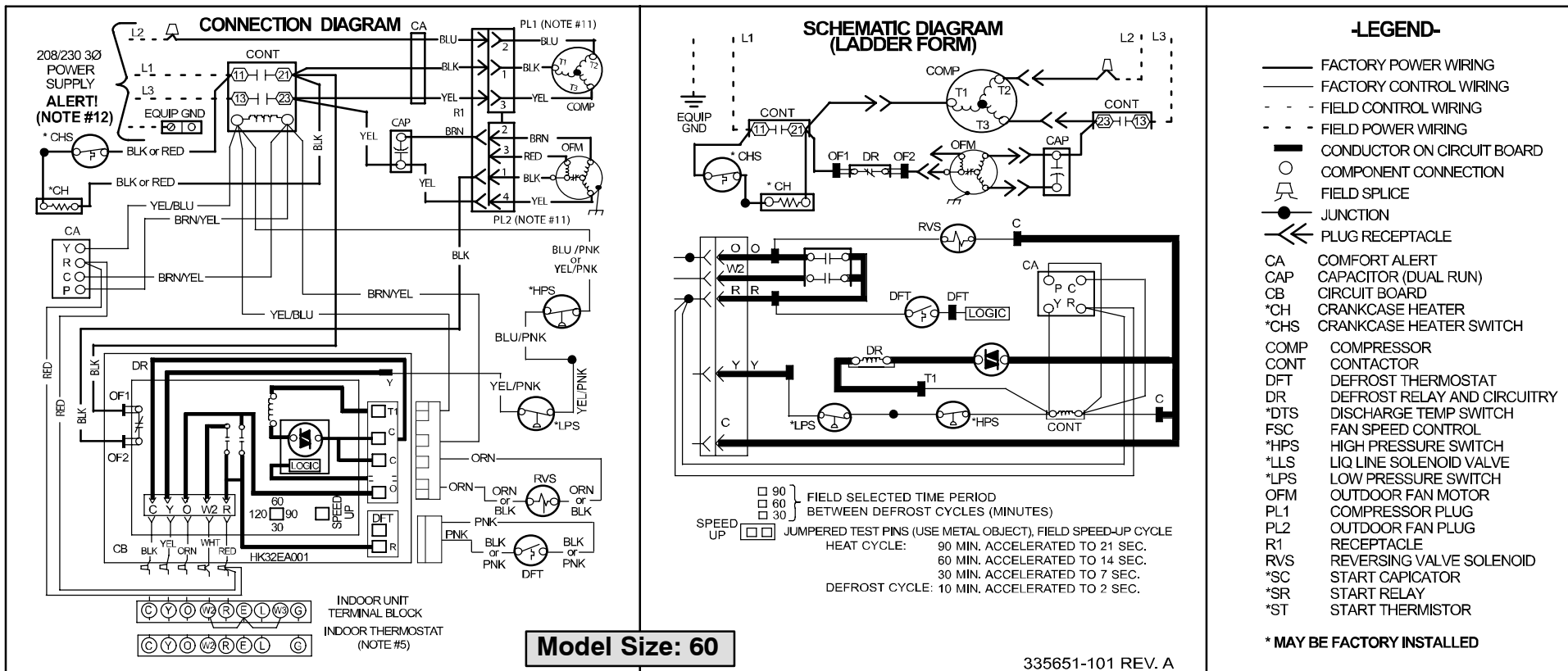

1. Symbols are electrical representation only.
2. Compressor and fan motor furnished with inherent thermal protection.
3. To be wired in accordance with National Electric N.E.C. and local codes.
4. N.E.C. class 2, 24 V circuit, min. 40 VA required, 60 VA on units installed with LLS.
5. Connection for typical heat pump thermostat. For other arrangements see installation instructions.
6. Use copper conductors only. Use conductors suitable for at least 75°C (167°F).
7. If indoor section has a transformer with a grounded secondary, connect the grounded side to "C" on the circuit board.
8. When start capacitor and relay are installed, start thermistor (PTC) is not used.
9. CH not used on all units.
10. If any of the original wire, as supplied, must be replaced, use the same or equivalent wire.
11. Check all electrical connections inside control box for tightness.
12. Do not attempt to operate unit until service valves have been opened.
13. Do not rapid cycle compressor. Compressor must be off 3 minutes to allow pressures to equalize between high and low side before starting.
14. It is imperative to connect 3-phase field power to unit with correct phasing. If phasing is reversed, interchange any two of the three power connections on field side.

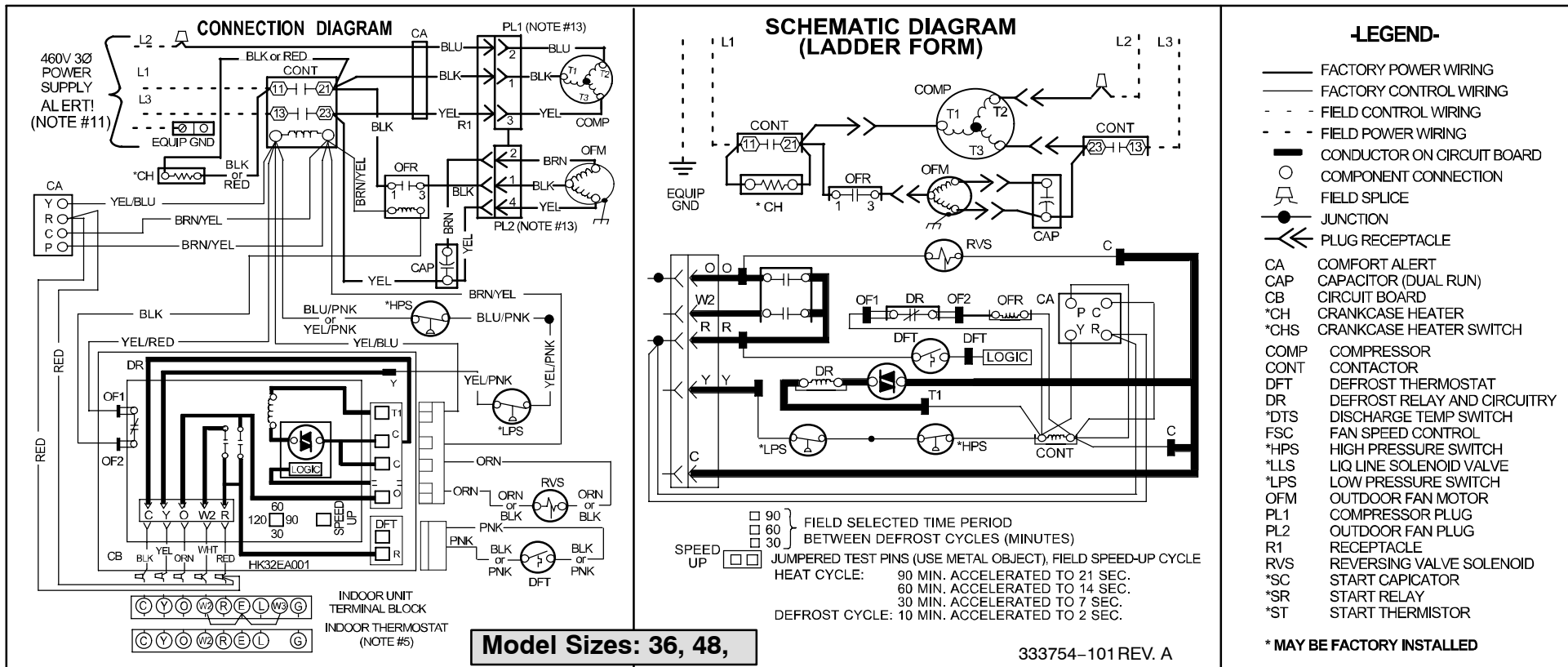

1. Symbols are electrical representation only.
2. Compressor and fan motor furnished with inherent thermal protection.
3. To be wired in accordance with National Electric N.E.C. and local codes.
4. N.E.C. class 2, 24 V circuit, min. 40 VA required, 60 VA on units installed with LLS.
5. Connection for typical heat pump thermostat. For other arrangements see installation instructions.
6. Use copper conductors only. Use conductors suitable for at least 75°C (167°F).
7. If indoor section has a transformer with a grounded secondary, connect the grounded side to "C" on the circuit board.
8. When start capacitor and relay are installed, start thermistor (PTC) is not used.
9. CH not used on all units.
10. If any of the original wire, as supplied, must be replaced, use the same or equivalent wire.
11. Check all electrical connections inside control box for tightness.
12. Do not attempt to operate unit until service valves have been opened.
13. Do not rapid cycle compressor. Compressor must be off 3 minutes to allow pressures to equalize between high and low side before starting.
14. It is imperative to connect 3-phase field power to unit with correct phasing. If phasing is reversed, interchange any two of the three power connections on field side.

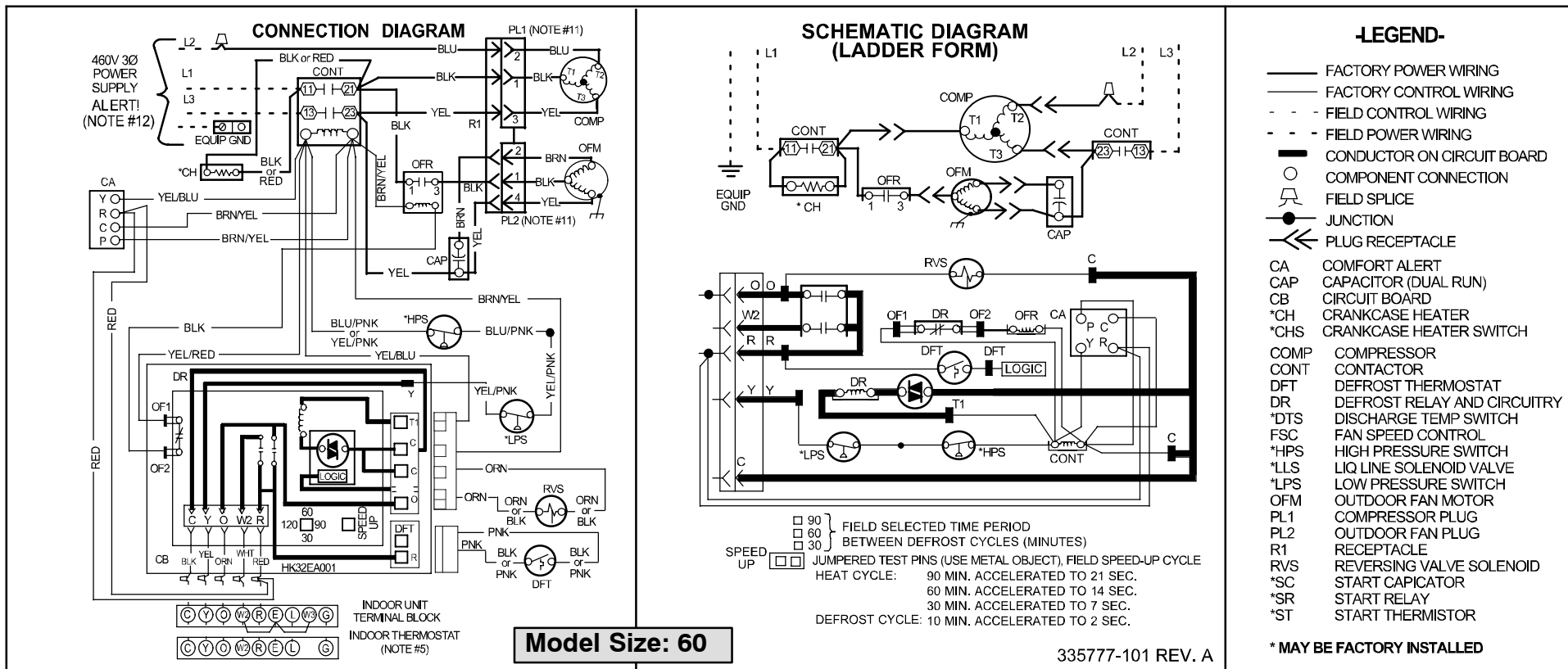

1. Symbols are electrical representation only.
2. Compressor and fan motor furnished with inherent thermal protection.
3. To be wired in accordance with National Electric N.E.C. and local codes.
4. N.E.C. class 2, 24 V circuit, min. 40 VA required, 60 VA on units installed with LLS.
5. Connection for typical heat pump thermostat. For other arrangements see installation instructions.
6. Use copper conductors only. Use conductors suitable for at least 75°C (167°F).
7. If indoor section has a transformer with a grounded secondary, connect the grounded side to "C" on the circuit board.
8. When start capacitor and relay are installed, start thermistor (PTC) is not used.
9. CH not used on all units.
10. If any of the original wire, as supplied, must be replaced, use the same or equivalent wire.
11. Check all electrical connections inside control box for tightness.
12. Do not attempt to operate unit until service valves have been opened.
13. Do not rapid cycle compressor. Compressor must be off 3 minutes to allow pressures to equalize between high and low side before starting.
14. It is imperative to connect 3-phase field power to unit with correct phasing. If phasing is reversed, interchange any two of the three power connections on field side.

R-410A CHARGING CHART												
Measured Liquid Pressure (psig)	Rating Plate (required) Subcooling Temperature °F (°C)											
	°F 6	(°C) 3	°F 8	(°C) 4	°F 10	(°C) 6	°F 12	(°C) 7	F 14	(°C) 8	F 16	(°C) 9
	R-410A Required Liquid Line Temperature °F (°C)											
251	78	26	76	24	74	23	72	22	70	21	68	20
259	80	27	78	26	76	24	74	23	72	22	70	21
266	82	28	80	27	78	26	76	24	74	23	72	22
274	84	29	82	28	80	27	78	26	76	24	74	23
283	86	30	84	29	82	28	80	27	78	26	76	24
291	88	31	86	30	84	29	82	28	80	27	78	26
299	90	32	88	31	86	30	84	29	82	28	80	27
308	92	33	90	32	88	31	86	30	84	29	82	28
317	94	34	92	33	90	32	88	31	86	30	84	29
326	96	36	94	34	92	33	90	32	88	31	86	30
335	98	37	96	36	94	34	92	33	90	32	88	31
345	100	38	98	37	96	36	94	34	92	33	90	32
364	104	40	102	39	100	38	98	37	96	36	94	34
374	106	41	104	40	102	39	100	38	98	37	96	36
384	108	42	106	41	104	40	102	39	100	38	98	37
395	110	43	108	42	106	41	104	40	102	39	100	38
406	112	44	110	43	108	42	106	41	104	40	102	39
416	114	46	112	44	110	43	108	42	106	41	104	40
427	116	47	114	46	112	44	110	43	108	42	106	41
439	118	48	116	47	114	46	112	44	110	43	108	42
450	120	49	118	48	116	47	114	46	112	44	110	43
462	122	50	120	49	118	48	116	47	114	46	112	44
474	124	51	122	50	120	49	118	48	116	47	114	46

8 MULTIPLYING FACTORS

(Refer to pages 9–13)

- † Total capacities are net (I.D. blower heat subtracted) system capacities based on 25' line set.
If additional tubing length and/or indoor unit is located above outdoor unit, a slight variation in capacity may occur.
- †† At TVA rating indoor condition (75 °F db, 63 °F wb), all other indoor air temperatures are at 80 °F db
If additional tubing length and/or indoor unit is located above outdoor unit, a slight variation in capacity may occur.
- * System amps are total of indoor and outdoor amps.
- ‡ Chart data is for 80° F indoor dry bulb. For indoor db temperatures other than 80° F, measure Indoor db and Indoor CFM, and plug these into the formula below. Measure outdoor db and indoor wet bulb, apply these to the chart above, find MBh and S/T, and plug these into the formula below.
(Note: if indoor db is the only thing changing, total capacity, MBh, stays the same.)

$$\text{Sensible Capacity at Indoor db LOWER than } 80^{\circ}\text{F} = (\text{MBh} \times \text{S/T}) - \left(\frac{(80 - \text{Indoor db}) \times 835 \times \text{Indoor CFM}}{1000} \right)$$

$$\text{Sensible Capacity at Indoor db HIGHER than } 80^{\circ}\text{F} = (\text{MBh} \times \text{S/T}) + \left(\frac{(\text{Indoor db} - 80) \times 835 \times \text{Indoor CFM}}{1000} \right)$$

COOLING		030 Size Outdoor With FS(M,U)4P30**A* Indoor Cooling																								
		Outdoor Ambient Temperature – Degrees F, Dry Bulb																								
		75					85					95					105					115				
		Entering Indoor Temperature – Degrees F, Wet Bulb																								
CFM		57	62	63††	67	72	57	62	63††	67	72	57	62	63††	67	72	57	62	63††	67	72	57	62	63††	67	72
875	MBh†	28.19	29.59	30.24	32.79	36.04	27.05	28.10	28.70	31.16	34.51	25.76	26.49	27.05	29.41	32.77	23.68	23.93	24.46	27.49	30.80	21.79	21.84	21.58	24.63	28.49
	S/T‡	1.00	0.91	0.72	0.70	0.52	1.00	0.93	0.74	0.71	0.52	1.00	0.95	0.76	0.73	0.53	1.00	1.00	0.79	0.75	0.54	1.00	1.00	0.83	0.79	0.55
	AMPS*	9.43	9.47	9.49	9.56	9.67	10.38	10.42	10.45	10.55	10.67	11.45	11.49	11.52	11.66	11.79	12.47	12.49	12.52	12.87	13.06	13.81	13.81	13.79	14.00	14.51
	HI PR	275	278	279	283	289	317	319	321	327	333	363	365	367	374	382	406	407	409	425	434	460	461	460	470	491
	LO PR	121	126	129	138	149	125	129	131	141	152	129	132	133	143	156	135	136	137	146	159	141	142	142	150	163
1000	MBh†	29.47	30.35	30.95	33.51	36.70	28.26	28.81	29.34	31.88	35.16	26.92	27.18	27.62	30.00	33.39	24.99	25.05	25.16	28.03	31.40	22.89	22.97	22.32	25.19	29.09
	S/T‡	1.00	0.95	0.75	0.72	0.53	1.00	0.97	0.77	0.74	0.54	1.00	1.00	0.79	0.76	0.54	1.00	1.00	0.82	0.78	0.56	1.00	1.00	0.87	0.83	0.57
	AMPS*	9.63	9.66	9.67	9.74	9.86	10.60	10.62	10.64	10.74	10.86	11.69	11.70	11.72	11.86	11.98	12.74	12.75	12.75	13.09	13.24	14.03	14.03	13.99	14.23	14.70
	HI PR	278	280	280	285	291	320	322	323	328	335	367	368	369	376	383	412	412	412	427	436	464	464	462	473	493
	LO PR	127	130	132	141	151	130	132	134	144	155	134	135	136	146	158	140	140	140	149	162	146	146	144	153	165
1125	MBh†	30.57	31.02	31.52	34.05	37.18	29.27	29.43	29.83	32.39	35.63	27.88	27.92	28.05	30.48	33.84	26.31	26.34	25.78	28.43	31.82	23.93	23.97	22.82	25.84	29.52
	S/T‡	1.00	0.98	0.78	0.75	0.54	1.00	1.01	0.80	0.77	0.55	1.00	1.00	0.82	0.79	0.56	1.00	1.00	0.85	0.82	0.57	1.00	1.00	0.91	0.86	0.59
	AMPS*	9.83	9.84	9.85	9.93	10.05	10.81	10.82	10.83	10.92	11.05	11.91	11.91	11.91	12.04	12.16	13.12	13.12	13.00	13.29	13.42	14.29	14.29	14.19	14.51	14.87
	HI PR	280	281	282	286	293	323	324	324	330	336	371	371	371	377	384	421	421	416	429	437	468	469	464	478	494
	LO PR	131	133	134	143	154	135	135	136	146	157	138	139	139	149	161	143	143	142	151	164	149	149	145	155	167

HEATING		030 Size Outdoor With FS(M,U)4P30**A* Indoor Heating																															
		Outdoor Ambient Temperature – Degrees F, Dry Bulb																															
		-3				7				17				27				37				47				57				67			
		Entering Indoor Temperature – Degrees F, Dry Bulb																															
CFM		65	70	75	65	70	75	65	70	75	65	70	75	65	70	75	65	70	75	65	70	75	65	70	75								
875	MBh†	10.66	10.18	9.68	13.93	13.46	12.95	17.49	17.00	16.48	21.91	21.45	20.43	25.80	25.38	25.00	30.03	29.57	29.10	34.69	34.19	33.68	39.03	38.55	38.06								
	T/R	12.10	11.60	11.00	15.80	15.30	14.70	19.90	19.30	18.70	24.90	24.40	23.10	29.40	28.80	28.30	34.20	33.60	33.00	39.50	38.80	38.10	44.40	43.80	43.10								
	AMPS*	8.46	8.80	9.16	8.84	9.20	9.57	9.22	9.59	9.98	9.70	10.09	10.43	10.12	10.56	11.03	10.62	11.08	11.56	11.11	11.59	12.09	11.56	12.04	12.55								
	HI PR	224	239	255	239	255	271	256	272	289	279	296	311	301	320	340	327	346	366	352	372	393	374	394	415								
	LO PR	37	37	37	47	48	48	59	59	60	73	73	74	88	88	89	105	106	106	123	124	125	139	140	141								
1000	MBh†	10.88	10.40	9.89	14.17	13.71	13.21	17.79	17.29	16.79	22.22	21.82	20.85	26.15	25.73	25.34	30.41	30.00	29.52	35.02	34.56	34.11	39.03	38.61	38.16								
	T/R	10.80	10.30	9.80	14.10	13.60	13.10	17.70	17.20	16.60	22.10	21.70	20.70	26.00	25.60	25.10	30.30	29.80	29.30	34.90	34.30	33.80	38.90	38.40	37.80								
	AMPS*	8.54	8.89	9.24	8.89	9.25	9.62	9.22	9.60	9.99	9.65	10.06	10.40	10.03	10.46	10.91	10.47	10.92	11.39	10.88	11.34	11.83	11.25	11.73	12.23								
	HI PR	220	236	252	234	250	266	249	266	283	270	288	303	290	309	328	313	333	353	335	355	375	354	374	395								
	LO PR	37	37	37	47	47	48	59	59	60	72	73	73	88	88	89	104	105	106	122	123	123	136	137	139								
1125	MBh†	11.08	10.60	10.09	14.39	13.94	13.43	18.03	17.56	17.05	22.47	22.10	21.26	26.45	26.04	25.61	30.78	30.34	29.89	35.19	34.77	34.34	38.92	38.54	38.13								
	T/R	9.80	9.40	8.90	12.70	12.30	11.80	16.00	15.50	15.00	19.90	19.50	18.70	23.40	23.00	22.60	27.20	26.80	26.30	31.10	30.70	30.20	34.40	34.00	33.60								
	AMPS*	8.64	8.99	9.34	8.96	9.32	9.70	9.26	9.64	10.04	9.65	10.06	10.42	9.99	10.42	10.86	10.40	10.84	11.30	10.73	11.19	11.67	11.05	11.53	12.02								
	HI PR	218	233	249	230	246	263	244	261	278	263	281	297	282	300	319	303	322	342	322	341	362	339	359	379								
	LO PR	37	37	37	47	47	48	59	59	60	72	73	73	88	88	88	104	105	105	120	121	122	134	135	136								

COOLING		036 Size Outdoor With FS(M,U)4P36**A* Indoor Cooling																								
		Outdoor Ambient Temperature – Degrees F, Dry Bulb																								
		75					85					95					105					115				
		Entering Indoor Temperature – Degrees F, Wet Bulb																								
CFM		57	62	63††	67	72	57	62	63††	67	72	57	62	63††	67	72	57	62	63††	67	72	57	62	63††	67	72
1050	MBh†	32.87	33.82	34.49	37.45	41.13	31.51	32.10	32.69	35.54	39.37	29.94	30.24	30.73	33.44	37.37	27.40	27.46	27.41	31.19	35.12	25.16	25.21	24.39	27.52	32.32
	S/T‡	1.00	0.92	0.73	0.70	0.51	1.00	0.94	0.75	0.72	0.52	1.00	0.97	0.77	0.74	0.53	1.00	1.00	0.81	0.76	0.54	1.00	1.00	0.86	0.81	0.56
	AMPS*	10.65	10.69	10.72	10.82	10.95	11.76	11.78	11.81	11.94	12.09	12.97	12.99	13.02	13.20	13.35	14.15	14.15	14.15	14.56	14.79	15.69	15.69	15.64	15.84	16.44
	HI PR	276	278	279	283	289	319	320	321	327	333	365	366	367	375	381	409	409	409	424	434	463	463	461	469	491
	LO PR	119	122	123	132	143	122	124	126	135	146	126	127	128	138	149	132	133	132	140	153	138	139	136	145	156
1200	MBh†	34.22	34.64	35.18	38.15	41.75	32.77	32.90	33.29	36.22	39.98	31.18	31.23	31.29	34.00	37.95	28.79	28.78	28.07	31.72	35.68	26.34	26.35	24.87	28.15	32.94
	S/T‡	1.00	0.96	0.76	0.73	0.53	1.00	0.99	0.78	0.75	0.54	1.00	1.00	0.80	0.78	0.55	1.00	1.00	0.85	0.80	0.56	1.00	1.00	0.90	0.86	0.58
	AMPS*	10.91	10.93	10.94	11.04	11.18	12.02	12.03	12.04	12.17	12.32	13.26	13.27	13.26	13.44	13.58	14.47	14.46	14.40	14.82	15.02	15.97	15.96	15.87	16.11	16.65
	HI PR	279	280	280	285	291	322	322	323	328	335	369	369	369	376	383	414	413	411	427	435	466	466	463	472	492
	LO PR	124	125	126	135	145	127	127	128	138	149	131	131	131	140	152	136	137	134	143	155	142	142	138	147	158
1350	MBh†	35.40	35.46	35.76	38.68	42.20	33.83	33.86	33.77	36.74	40.43	32.18	32.23	31.73	34.56	38.38	30.09	30.36	28.61	32.12	36.08	27.39	27.43	25.36	28.66	33.37
	S/T‡	1.00	1.00	0.79	0.76	0.54	1.00	1.00	0.81	0.79	0.55	1.00	1.00	0.84	0.81	0.56	1.00	1.00	0.88	0.84	0.58	1.00	1.00	0.94	0.90	0.60
	AMPS*	11.15	11.15	11.16	11.26	11.40	12.28	12.28	12.27	12.39	12.54	13.54	13.54	13.50	13.65	13.81	14.83	14.92	14.65	15.07	15.24	16.26	16.26	16.11	16.38	16.87
	HI PR	281	281	281	286	292	325	325	324	330	336	373	373	371	377	384	420	423	413	429	436	470	470	464	475	493
	LO PR	128	128	128	137	147	131	131	131	140	151	135	135	133	142	154	139	139	136	145	157	145	146	140	149	160

HEATING		036 Size Outdoor With FS(M,U)4P36**A* Indoor Heating																							
		Outdoor Ambient Temperature – Degrees F, Dry Bulb																							
		-3			7			17			27			37			47			57			67		
		Entering Indoor Temperature – Degrees F, Dry Bulb																							
CFM		65	70	75	65	70	75	65	70	75	65	70	75	65	70	75	65	70	75	65	70	75			
1050	MBh†	12.21	11.61	10.96	15.85	15.28	14.65	19.91	19.31	18.70	24.90	24.43	23.29	29.27	28.81	28.36	34.05	33.54	33.08	39.64	39.06	38.47	44.76	44.26	43.74
	T/R	11.30	10.70	10.10	14.60	14.10	13.50	18.40	17.80	17.20	23.00	22.50	21.40	27.00	26.50	26.00	31.40	30.90	30.40	36.60	36.00	35.30	41.30	40.70	40.20
	AMPS*	9.29	9.72	10.16	9.68	10.11	10.55	10.09	10.52	10.98	10.62	11.08	11.48	11.09	11.58	12.11	11.65	12.15	12.69	12.22	12.75	13.31	12.75	13.29	13.87
	HI PR	222	237	252	236	252	268	253	269	286	275	292	307	296	315	334	320	340	359	345	365	385	367	388	409
	LO PR	36	36	36	46	46	47	58	58	59	71	71	72	86	86	87	102	103	103	120	121	122	136	137	138
1200	MBh†	12.45	11.87	11.22	16.15	15.58	14.96	20.25	19.66	19.04	25.22	24.79	23.82	29.67	29.19	28.72	34.53	34.00	33.47	40.03	39.52	38.97	44.72	44.28	43.79
	T/R	10.10	9.60	9.00	13.00	12.60	12.00	16.40	15.80	15.30	20.40	20.00	19.10	24.00	23.50	23.10	27.90	27.40	26.90	32.30	31.80	31.30	36.10	35.70	35.20
	AMPS*	9.40	9.82	10.27	9.75	10.18	10.63	10.12	10.56	11.01	10.59	11.06	11.47	11.03	11.50	12.02	11.53	12.03	12.55	12.01	12.52	13.07	12.47	13.00	13.55
	HI PR	219	234	250	232	247	264	247	263	280	267	285	300	286	305	324	309	328	347	329	349	370	349	369	390
	LO PR	36	36	36	46	46	47	58	58	58	71	71	72	86	86	87	102	102	103	119	120	121	134	135	136
1350	MBh†	12.72	12.11	11.45	16.44	15.85	15.22	20.56	19.97	19.35	25.51	25.09	24.61	29.99	29.54	29.07	34.94	34.39	33.86	40.21	39.75	39.27	44.54	44.15	43.72
	T/R	9.10	8.70	8.20	11.80	11.30	10.90	14.80	14.30	13.80	18.30	18.00	17.60	21.50	21.20	20.80	25.10	24.60	24.20	28.90	28.50	28.10	32.00	31.60	31.20
	AMPS*	9.52	9.95	10.40	9.85	10.28	10.73	10.18	10.62	11.08	10.62	11.09	11.57	11.01	11.50	12.00	11.49	11.98	12.49	11.89	12.40	12.93	12.29	12.82	13.36
	HI PR	217	232	247	228	244	261	242	258	276	260	278	296	278	297	316	299	318	338	318	337	357	335	355	376
	LO PR	36	36	36	46	46	47	57	58	58	71	71	71	85	86	86	101	102	103	118	119	120	131	132	134

COOLING		042 Size Outdoor With FS(M,U)4P42**A* Indoor Cooling																								
		Outdoor Ambient Temperature – Degrees F, Dry Bulb																								
		75					85					95					105					115				
		Entering Indoor Temperature – Degrees F, Wet Bulb																								
CFM		57	62	63††	67	72	57	62	63††	67	72	57	62	63††	67	72	57	62	63††	67	72	57	62	63††	67	72
1225	MBh†	39.22	40.82	41.67	45.21	49.72	37.50	38.60	39.39	42.76	47.29	35.64	36.30	36.98	40.16	44.72	32.84	32.90	33.46	37.51	41.99	30.17	30.22	29.80	33.59	38.99
	S/T‡	1.00	0.90	0.71	0.69	0.51	1.00	0.92	0.73	0.70	0.51	1.00	0.95	0.75	0.72	0.52	1.00	1.00	0.78	0.74	0.53	1.00	1.00	0.83	0.78	0.55
	AMPS*	12.79	12.78	12.77	12.66	12.46	14.27	14.28	14.29	14.28	14.17	15.84	15.87	15.90	16.00	15.94	17.33	17.33	17.37	17.78	17.83	19.09	19.10	19.06	19.43	19.86
	HI PR	291	294	295	301	309	336	339	340	347	355	386	388	389	397	405	434	434	435	451	459	488	489	487	501	517
	LO PR	123	128	130	139	150	127	130	132	142	154	131	133	135	145	157	138	138	139	148	160	144	144	143	152	163
1400	MBh†	40.93	41.82	42.65	46.14	50.57	39.09	39.55	40.19	43.65	48.10	37.15	37.22	37.69	41.00	45.44	34.73	34.82	34.41	38.19	42.65	31.67	31.73	30.48	34.49	39.61
	S/T‡	1.00	0.94	0.74	0.71	0.52	1.00	0.96	0.76	0.73	0.53	1.00	1.00	0.78	0.76	0.54	1.00	1.00	0.82	0.78	0.55	1.00	1.00	0.87	0.82	0.56
	AMPS*	12.99	12.98	13.00	12.83	12.64	14.51	14.51	14.52	14.49	14.35	16.14	16.14	16.15	16.21	16.15	17.77	17.78	17.71	18.03	18.06	19.47	19.48	19.35	19.78	20.09
	HI PR	294	296	298	303	311	340	341	342	349	357	391	391	392	399	407	442	442	440	453	461	494	495	490	505	519
	LO PR	129	131	133	142	153	133	134	135	145	156	136	137	138	148	159	142	142	141	151	162	148	148	145	154	165
1575	MBh†	42.40	42.70	43.32	46.84	51.18	40.43	40.49	40.80	44.29	48.67	38.38	38.42	38.21	41.62	45.96	36.20	36.25	35.46	38.79	43.10	32.99	33.05	31.05	35.46	40.03
	S/T‡	1.00	0.97	0.77	0.74	0.53	1.00	1.00	0.79	0.76	0.54	1.00	1.00	0.82	0.79	0.55	1.00	1.00	0.85	0.82	0.57	1.00	1.00	0.91	0.86	0.58
	AMPS*	13.18	13.16	13.15	13.01	12.82	14.74	14.74	14.74	14.68	14.55	16.40	16.40	16.39	16.41	16.36	18.16	18.17	18.10	18.25	18.29	19.85	19.86	19.64	20.20	20.33
	HI PR	297	298	299	305	312	344	344	344	351	359	394	394	393	400	409	448	448	445	454	462	500	500	493	511	520
	LO PR	133	134	135	144	155	137	137	138	147	158	141	141	140	150	161	145	145	143	153	164	151	152	147	156	167

HEATING		042 Size Outdoor With FS(M,U)4P42**A* Indoor Heating																							
		Outdoor Ambient Temperature – Degrees F, Dry Bulb																							
		-3			7			17			27			37			47			57			67		
		Entering Indoor Temperature – Degrees F, Dry Bulb																							
CFM		65	70	75	65	70	75	65	70	75	65	70	75	65	70	75	65	70	75	65	70	75	65	70	75
1225	MBh†	14.25	13.53	12.75	18.84	18.13	17.35	23.67	22.95	22.20	28.90	28.14	27.36	35.02	34.47	33.85	40.59	39.94	39.32	47.12	46.37	45.63	54.78	53.89	52.95
	T/R	11.00	10.40	9.80	14.50	13.90	13.30	18.20	17.60	17.00	22.30	21.60	21.00	27.00	26.50	26.00	31.30	30.70	30.10	36.30	35.60	35.00	42.20	41.40	40.60
	AMPS*	10.03	10.65	11.30	10.76	11.32	11.90	11.54	12.06	12.62	12.33	12.85	13.38	13.21	13.76	14.33	13.90	14.47	15.09	14.52	15.14	15.79	15.08	15.80	16.55
	HI PR	222	237	252	236	251	267	251	267	284	269	286	303	292	311	330	314	333	353	340	359	379	369	389	411
	LO PR	33	34	34	43	44	44	55	55	56	67	68	68	82	82	82	98	98	99	117	117	118	138	139	139
1400	MBh†	14.58	13.84	13.05	19.22	18.49	17.73	24.10	23.38	22.63	29.47	28.63	27.85	35.50	34.93	34.35	41.16	40.50	39.84	47.85	47.08	46.32	55.62	54.80	53.95
	T/R	9.80	9.30	8.80	13.00	12.40	11.90	16.20	15.70	15.20	19.90	19.30	18.70	23.90	23.50	23.00	27.70	27.20	26.70	32.20	31.70	31.10	37.50	36.90	36.20
	AMPS*	10.12	10.75	11.41	10.82	11.39	11.98	11.57	12.09	12.65	12.32	12.83	13.37	13.13	13.68	14.25	13.75	14.33	14.93	14.30	14.91	15.55	14.65	15.37	16.10
	HI PR	219	234	249	231	247	263	245	262	279	261	278	296	282	301	320	302	321	341	326	345	365	351	371	392
	LO PR	33	34	34	43	44	44	55	55	55	67	68	68	82	82	82	98	98	99	116	117	117	137	138	139
1575	MBh†	14.86	14.12	13.33	19.53	18.81	18.05	24.45	23.74	22.99	30.07	29.06	28.28	35.90	35.35	34.76	41.65	40.98	40.32	48.46	47.68	46.90	56.12	55.39	54.61
	T/R	8.90	8.40	7.90	11.70	11.20	10.80	14.60	14.20	13.70	18.00	17.40	16.90	21.50	21.10	20.70	24.90	24.50	24.00	29.00	28.50	28.00	33.60	33.10	32.60
	AMPS*	10.24	10.87	11.53	10.92	11.48	12.08	11.64	12.17	12.72	12.38	12.88	13.41	13.12	13.67	14.24	13.69	14.27	14.86	14.17	14.79	15.42	14.39	15.09	15.82
	HI PR	216	231	247	228	244	260	240	257	274	256	272	290	274	293	312	293	312	332	315	334	354	337	357	377
	LO PR	33	34	34	43	44	44	54	55	55	67	67	68	81	82	82	98	98	98	116	117	117	136	137	138

COOLING		048 Size Outdoor With FS(M,U)4P48**A* Indoor Cooling																								
		Outdoor Ambient Temperature - Degrees F, Dry Bulb																								
		75					85					95					105					115				
		Entering Indoor Temperature - Degrees F, Wet Bulb																								
CFM		57	62	63†	67	72	57	62	63†	67	72	57	62	63†	67	72	57	62	63†	67	72	57	62	63†	67	72
1400	MBh†	44.75	46.64	47.63	51.73	56.73	42.85	44.16	45.07	48.96	54.26	40.89	41.69	42.48	46.12	51.46	38.73	39.06	39.75	43.28	48.38	35.24	35.32	35.14	40.21	45.13
	S/T‡	1.00	0.90	0.72	0.69	0.51	1.00	0.92	0.73	0.70	0.51	1.00	0.95	0.75	0.72	0.52	1.00	0.98	0.77	0.74	0.53	1.00	1.00	0.82	0.77	0.55
	AMPS*	14.50	14.52	14.53	14.46	14.38	16.21	16.25	16.27	16.38	16.36	17.99	18.03	18.06	18.23	18.35	19.90	19.93	19.96	20.20	20.41	21.85	21.85	21.83	22.33	22.63
	HI PR	277	280	281	284	289	319	321	322	329	333	366	368	369	375	381	417	418	419	426	433	469	469	468	480	490
	LO PR	124	128	130	140	150	127	131	133	143	154	131	133	135	145	158	135	136	138	148	161	142	143	142	151	164
1600	MBh†	46.75	47.79	48.72	52.82	57.59	44.69	45.24	46.02	50.01	55.20	42.59	42.70	43.30	47.00	52.34	40.38	40.44	40.49	44.03	49.24	37.22	37.30	36.09	40.91	45.93
	S/T‡	1.00	0.94	0.75	0.72	0.52	1.00	0.97	0.76	0.74	0.53	1.00	1.00	0.78	0.76	0.54	1.00	1.00	0.81	0.78	0.55	1.00	1.00	0.86	0.81	0.57
	AMPS*	14.81	14.81	14.82	14.71	14.66	16.56	16.57	16.60	16.65	16.65	18.38	18.38	18.40	18.58	18.65	20.32	20.32	20.32	20.55	20.73	22.33	22.34	22.21	22.69	22.95
	HI PR	280	281	282	285	290	323	323	324	329	334	370	370	370	377	383	421	421	421	428	435	474	474	471	483	491
	LO PR	129	132	134	143	152	133	134	136	146	157	137	137	138	148	161	141	141	141	151	164	146	147	144	153	167
1800	MBh†	48.48	48.86	49.56	53.60	58.16	46.26	46.33	46.72	50.78	55.85	44.01	44.07	43.90	47.70	52.99	41.70	41.76	41.06	44.57	49.84	39.19	39.24	36.89	41.43	46.49
	S/T‡	1.00	0.98	0.78	0.74	0.53	1.00	1.00	0.80	0.77	0.54	1.00	1.00	0.82	0.79	0.56	1.00	1.00	0.85	0.82	0.57	1.00	1.00	0.89	0.85	0.59
	AMPS*	15.10	15.09	15.08	14.98	14.94	16.90	16.90	16.91	16.93	16.94	18.74	18.74	18.72	18.89	18.95	20.70	20.71	20.66	20.88	21.04	22.87	22.87	22.60	23.04	23.27
	HI PR	282	283	283	286	291	325	325	326	330	336	372	372	372	378	384	424	424	422	429	436	479	479	473	484	492
	LO PR	134	135	136	145	154	138	138	138	148	159	141	141	141	151	163	145	145	143	153	166	149	150	146	156	169

HEATING		048 Size Outdoor With FS(M,U)4P48**A* Indoor Heating																							
		Outdoor Ambient Temperature - Degrees F, Dry Bulb																							
		-3			7			17			27			37			47			57			67		
		Entering Indoor Temperature - Degrees F, Dry Bulb																							
CFM		65	70	75	65	70	75	65	70	75	65	70	75	65	70	75	65	70	75	65	70	75			
1400	MBh†	18.01	17.38	16.69	23.17	22.54	21.85	28.77	28.07	27.33	35.00	34.54	34.06	40.92	40.31	39.73	47.57	46.83	46.11	55.36	54.47	53.62	64.43	63.45	62.50
	T/R	12.30	11.80	11.30	15.80	15.30	14.80	19.60	19.10	18.50	23.80	23.50	23.10	27.90	27.40	26.90	32.40	31.80	31.30	37.70	37.00	36.40	43.90	43.10	42.40
	AMPS*	12.59	13.09	13.64	13.11	13.63	14.19	13.69	14.23	14.81	14.38	14.99	15.63	15.06	15.69	16.36	15.83	16.50	17.21	16.78	17.49	18.22	17.65	18.44	19.25
	HI PR	224	240	256	238	254	271	254	271	288	273	292	311	293	312	331	316	335	355	346	365	385	374	394	415
	LO PR	35	35	36	45	46	46	57	57	58	70	70	71	85	85	86	101	102	102	121	121	122	142	143	143
1600	MBh†	18.35	17.74	17.05	23.55	22.93	22.25	29.22	28.53	27.81	35.43	34.99	34.51	41.47	40.86	40.26	48.25	47.50	46.76	56.21	55.30	54.42	65.12	64.27	63.39
	T/R	10.90	10.60	10.10	14.00	13.60	13.20	17.40	17.00	16.50	21.10	20.80	20.50	24.70	24.30	23.90	28.80	28.20	27.70	33.50	32.90	32.30	38.80	38.20	37.60
	AMPS*	12.76	13.26	13.81	13.24	13.75	14.31	13.75	14.30	14.87	14.38	14.99	15.62	14.99	15.63	16.28	15.68	16.35	17.05	16.55	17.26	17.99	17.27	18.04	18.83
	HI PR	220	236	253	233	249	267	247	264	282	265	283	302	283	301	321	304	323	343	332	351	371	357	376	397
	LO PR	35	35	36	45	46	46	57	57	58	70	70	70	85	85	85	101	102	102	120	121	121	141	142	143
1800	MBh†	18.65	18.06	17.37	23.89	23.29	22.61	29.73	28.95	28.22	35.82	35.34	34.89	41.95	41.33	40.72	48.83	48.07	47.32	56.97	56.03	55.09	65.45	64.66	63.83
	T/R	9.90	9.50	9.20	12.70	12.30	11.90	15.70	15.30	14.90	19.00	18.70	18.40	22.20	21.80	21.50	25.90	25.40	25.00	30.20	29.60	29.10	34.70	34.20	33.70
	AMPS*	12.95	13.45	14.00	13.40	13.91	14.46	13.88	14.41	14.98	14.45	15.05	15.67	15.01	15.65	16.29	15.64	16.32	17.01	16.32	17.10	17.88	17.05	17.81	18.60
	HI PR	218	234	250	229	246	263	242	259	277	258	276	295	275	293	313	295	314	334	319	339	360	344	363	384
	LO PR	35	35	36	45	46	46	57	57	57	70	70	70	85	85	85	101	101	102	120	121	121	140	141	142

COOLING		060 Size Outdoor With FS(M,U)4X60**** Indoor Cooling																								
		Outdoor Ambient Temperature - Degrees F, Dry Bulb																								
		75					85					95					105					115				
		Entering Indoor Temperature - Degrees F, Wet Bulb																								
CFM		57	62	63††	67	72	57	62	63††	67	72	57	62	63††	67	72	57	62	63††	67	72	57	62	63††	67	72
1750	MBh†	57.36	59.39	60.53	64.73	70.28	55.12	56.60	57.68	61.72	67.10	52.73	53.67	54.66	58.50	63.63	50.21	50.63	51.50	55.15	60.01	47.45	47.46	48.09	51.50	56.06
	S/T‡	1.00	0.89	0.71	0.68	0.50	1.00	0.91	0.72	0.70	0.51	1.00	0.94	0.74	0.71	0.52	1.00	0.96	0.76	0.73	0.52	1.00	1.00	0.78	0.75	0.54
	AMPS*	19.05	19.15	19.19	19.39	19.65	21.05	21.12	21.17	21.37	21.63	23.25	23.30	23.35	23.55	23.81	25.67	25.69	25.73	25.94	26.21	28.32	28.32	28.35	28.56	28.82
	HI PR	285	287	288	292	297	329	330	331	336	341	376	377	378	383	389	428	429	430	435	441	485	485	486	491	497
	LO PR	125	129	131	141	155	128	131	133	144	157	131	134	136	146	159	135	136	138	148	162	139	139	140	150	164
2000	MBh†	59.46	60.48	61.54	65.72	71.26	57.07	57.63	58.58	62.60	67.97	54.53	54.66	55.44	59.26	64.37	51.85	51.85	52.17	55.79	60.64	48.92	48.91	48.63	52.01	56.56
	S/T‡	1.00	0.94	0.74	0.71	0.52	1.00	0.96	0.75	0.73	0.52	1.00	0.99	0.77	0.75	0.53	1.00	1.00	0.79	0.77	0.54	1.00	1.00	0.82	0.79	0.56
	AMPS*	19.62	19.67	19.71	19.91	20.17	21.62	21.65	21.69	21.89	22.15	23.82	23.83	23.86	24.06	24.33	26.24	26.24	26.25	26.45	26.72	28.89	28.89	28.86	29.07	29.32
	HI PR	287	288	289	293	298	331	332	333	337	342	379	379	380	384	390	431	431	431	436	442	488	488	487	492	498
	LO PR	130	133	135	145	159	133	135	137	147	160	137	137	138	149	163	140	140	141	151	165	144	144	143	153	167
2250	MBh†	61.15	61.41	62.26	66.42	71.95	58.65	58.65	59.21	63.21	68.56	55.97	55.97	55.98	59.77	64.87	53.16	53.15	52.62	56.21	61.04	50.07	50.06	49.00	52.34	56.86
	S/T‡	1.00	0.97	0.77	0.74	0.53	1.00	1.00	0.78	0.76	0.54	1.00	1.00	0.80	0.78	0.55	1.00	1.00	0.83	0.81	0.56	1.00	1.00	0.86	0.83	0.58
	AMPS*	20.17	20.18	20.22	20.42	20.67	22.17	22.17	22.19	22.39	22.65	24.37	24.37	24.36	24.57	24.83	26.79	26.79	26.75	26.95	27.21	29.43	29.43	29.36	29.56	29.82
	HI PR	289	290	290	294	299	333	333	334	338	343	381	381	381	385	391	433	433	432	437	443	490	490	488	493	499
	LO PR	135	136	137	148	161	138	138	139	149	163	141	141	141	151	165	145	145	143	153	167	149	149	145	156	170

HEATING		060 Size Outdoor With FS(M,U)4X60**** Indoor Heating																							
		Outdoor Ambient Temperature - Degrees F, Dry Bulb																							
		-3			7			17			27			37			47			57			67		
		Entering Indoor Temperature - Degrees F, Dry Bulb																							
CFM		65	70	75	65	70	75	65	70	75	65	70	75	65	70	75	65	70	75	65	70	75			
1750	MBh†	24.57	23.76	22.90	30.47	29.75	28.96	36.69	36.02	35.29	43.32	42.67	42.00	50.72	49.99	49.25	58.76	58.00	57.22	66.48	65.66	64.84	74.57	73.71	72.82
	T/R	14.10	13.70	13.30	17.60	17.30	17.00	21.30	21.10	20.80	25.30	25.20	25.00	29.90	29.70	29.50	35.00	34.80	34.60	39.90	39.70	39.60	45.20	45.00	44.90
	AMPS*	16.03	16.71	17.40	16.75	17.50	18.27	17.49	18.29	19.12	18.30	19.16	20.05	19.25	20.16	21.10	20.05	20.99	21.98	21.05	22.04	23.07	22.17	23.21	24.28
	HI PR	230	246	263	243	260	277	258	276	294	276	294	314	295	315	335	314	334	355	337	358	380	363	385	408
	LO PR	34	35	35	44	45	45	56	56	57	68	69	69	83	83	84	97	98	99	112	113	114	127	128	129
2000	MBh†	25.10	24.29	23.43	31.01	30.31	29.54	37.29	36.63	35.89	43.97	43.31	42.66	51.55	50.73	50.01	59.18	58.52	57.81	66.76	66.06	65.31	73.14	73.11	72.79
	T/R	12.50	12.20	11.90	15.60	15.40	15.10	18.90	18.70	18.50	22.40	22.20	22.10	26.40	26.20	26.10	30.60	30.50	30.40	34.70	34.70	34.60	38.30	38.70	38.80
	AMPS*	16.31	16.99	17.69	16.96	17.71	18.49	17.62	18.42	19.25	18.34	19.19	20.08	19.14	20.07	21.03	19.86	20.79	21.76	20.72	21.70	22.72	21.46	22.57	23.69
	HI PR	226	242	259	237	254	272	251	269	287	267	285	304	284	303	324	300	320	341	320	341	363	337	361	385
	LO PR	34	35	35	44	45	45	56	56	56	68	69	69	83	83	83	96	97	98	110	111	112	122	124	126
2250	MBh†	25.59	24.78	23.92	31.52	30.81	30.05	37.81	37.15	36.44	44.55	43.89	43.22	52.26	51.46	50.75	59.42	58.83	58.23	66.69	66.14	65.53	70.31	70.72	70.80
	T/R	11.30	11.10	10.80	14.00	13.90	13.60	16.90	16.80	16.60	20.10	19.90	19.80	23.70	23.50	23.40	27.10	27.10	27.00	30.60	30.60	30.60	32.40	32.90	33.20
	AMPS*	16.63	17.30	18.01	17.22	17.97	18.75	17.82	18.62	19.44	18.49	19.33	20.27	19.15	20.07	21.01	19.82	20.75	21.70	20.57	21.54	22.54	20.88	21.99	23.12
	HI PR	222	239	256	233	250	267	246	263	281	260	278	297	274	294	314	290	310	330	307	328	350	315	339	363
	LO PR	34	35	35	44	45	45	56	56	56	68	69	69	82	83	83	95	96	97	108	109	111	114	117	120

COOLING Multiplying Factors for other Indoor Combinations

Indoor Model	Furnace Model	Capac. (MBh)	Power (AMPS)	Indoor Model	Furnace Model	Capac. (MBh)	Power (AMPS)	Indoor Model	Furnace Model	Capac. (MBh)	Power (AMPS)
H4H330											
>FS(M,U)4P30**A*		1.00	1.00	FXM4X30**A*		1.00	0.96	EHD4X36A**	MV08B15**B*	1.00	0.96
ED*4X30B**	*8MV*0701412**	1.00	1.00	FXM4X36**A*		1.00	0.92	EHD4X36A**	MV12F19**B*	1.00	0.96
ED*4X30B**	MV08B15**B*	1.00	0.96	EHD4X30A**	*8MV*1102120**	1.00	0.96	EHD4X36A**	NOMV106D12*	1.00	0.96
ED*4X30F**	*8MPV075	1.00	1.00	EHD4X30A**	*8MV*1352422**	1.00	0.96	EN(A,D)4X30*14**	*8MV*0701412**	1.00	1.00
ED*4X30F**	*8MV*0901716**	1.00	0.96	EHD4X30A**	*8MX*0701716**	1.00	1.00	EN(A,D)4X30*17**	*8MV*0901716**	1.00	0.96
ED*4X30F**	*8MX*0701716**	1.00	1.00	EHD4X30A**	*8MX*0902116**	1.00	0.96	EN(A,D)4X30*17**	*8MX*0701716**	1.00	1.00
ED*4X30F**	*9MPV050	1.00	1.00	EHD4X30A**	*9MPV050	1.00	1.00	EN(A,D)4X36*21**	*8MV*1102120**	1.00	0.96
ED*4X30F**	*9MPV075	1.00	1.00	EHD4X30A**	*9MPV075	1.00	1.00	EN(A,D)4X36*21**	*8MX*0902116**	1.00	1.00
ED*4X30F**	*9MVX040	1.00	1.00	EHD4X30A**	*9MPV100	1.00	1.00	EN(A,D,W)4X36*17**	*8MV*0901716**	1.00	0.96
ED*4X30F**	*9MVX060	1.00	1.00	EHD4X30A**	*9MPV125	1.00	1.00	EN(A,D,W)4X36*17**	*8MX*0701716**	1.00	1.00
ED*4X30F**	MV12F19**B*	1.00	0.96	EHD4X30A**	*9MVX040	1.00	1.00	ENH4X30*17**	*8MV*0701412**	1.00	1.00
ED*4X36B**	*8MV*0701412**	1.00	1.00	EHD4X30A**	*9MVX060	1.00	1.00	ENH4X30*17**	*8MV*0901716**	1.00	0.96
ED*4X36B**	MV08B15**B*	1.00	0.96	EHD4X30A**	*9MVX080	1.00	1.00	ENH4X30*17**	*8MV*1102120**	1.00	0.96
ED*4X36F**	*8MPV075	1.00	1.00	EHD4X30A**	*9MVX100	1.00	1.00	ENH4X30*17**	*8MV*1352422**	1.00	0.96
ED*4X36F**	*8MV*0901716**	1.00	0.96	EHD4X30A**	MV08B15**B*	1.00	0.96	ENH4X30*17**	*8MX*0701716**	1.00	1.00
ED*4X36F**	*8MX*0701716**	1.00	1.00	EHD4X30A**	MV12F19**B*	1.00	0.96	ENH4X30*17**	*8MX*0902116**	1.00	0.96
ED*4X36F**	*9MPV050	1.00	1.00	EHD4X36A**	*8MPV050	1.00	1.00	ENH4X36*17**	*8MV*0701412**	1.00	1.00
ED*4X36F**	*9MPV075	1.00	1.00	EHD4X36A**	*8MPV075	1.00	0.96	ENH4X36*17**	*8MV*0901716**	1.00	0.96
ED*4X36F**	*9MVX040	1.00	1.00	EHD4X36A**	*8MPV100	1.00	0.96	ENH4X36*17**	*8MV*1102120**	1.00	0.96
ED*4X36F**	*9MVX060	1.00	1.00	EHD4X36A**	*8MPV125	1.00	0.96	ENH4X36*17**	*8MV*1352422**	1.00	0.96
ED*4X36F**	MV12F19**B*	1.00	0.96	EHD4X36A**	*8MV*0701412**	1.00	0.96	ENH4X36*17**	*8MX*0701716**	1.00	1.00
ED*4X36F**	NOMV106D12*	0.99	0.99	EHD4X36A**	*8MV*0901716**	1.00	0.96	ENH4X36*17**	*8MX*0902116**	1.00	1.00
ED*4X36J**	*8MPV100	1.00	0.96	EHD4X36A**	*8MV*1102120**	1.00	0.96	FEA4X30**A*		1.00	1.00
ED*4X36J**	*8MPV125	1.00	0.96	EHD4X36A**	*8MV*1352422**	1.00	0.96	FEA4X36**A*		1.00	1.00
ED*4X36J**	*8MV*1102120**	1.00	0.96	EHD4X36A**	*8MX*0701716**	1.00	0.96	FEM4P30**A*		1.00	1.00
ED*4X36J**	*8MX*0902116**	1.00	0.96	EHD4X36A**	*8MX*0902116**	1.00	0.96	FEM4P30**A*		1.00	1.00
ED*4X36J**	*9MPV100	1.00	0.96	EHD4X36A**	*9MPV050	1.00	1.00	FEM4P36**A*		1.00	1.00
ED*4X36J**	*9MVX080	1.00	0.96	EHD4X36A**	*9MPV075	1.00	1.00	FEM4P36**A*		1.00	1.00
EHD4X30A**	*8MPV050	1.00	1.00	EHD4X36A**	*9MPV100	1.00	0.96	FEM4X30****		1.00	1.00
EHD4X30A**	*8MPV075	1.00	1.00	EHD4X36A**	*9MPV125	1.00	0.96	FEM4X36****		1.00	1.00
EHD4X30A**	*8MPV100	1.00	1.00	EHD4X36A**	*9MVX040	1.00	1.00	FS(M,U)4P30**A*		1.00	1.00
EHD4X30A**	*8MPV125	1.00	0.96	EHD4X36A**	*9MVX060	1.00	1.00	FVM4X24****		1.00	0.96
EHD4X30A**	*8MV*0701412**	1.00	1.00	EHD4X36A**	*9MVX080	1.00	0.96	FVM4X36****		1.00	0.96
EHD4X30A**	*8MV*0901716**	1.00	0.96	EHD4X36A**	*9MVX100	1.00	0.96	FVM4X48****		1.00	0.96
H4H336											
>FS(M,U)4P36**A*		1.00	1.00	EN(A,D,W)4X36*17**	NOMV106D12*	0.99	0.95	EN(A,D,W)4X36*17**		0.99	0.99
ED*4X36B**	*8MPV050	0.99	0.99	EHD4X36A**	*8MX*1102120**	0.99	0.95	EN(A,D,W)4X42*21**	*8MV*1102120**	1.00	0.96
ED*4X36B**	*8MV*0701412**	0.99	0.95	EHD4X36A**	*9MPV050	0.99	0.99	EN(A,D,W)4X42*21**	*8MX*0902116**	1.00	0.96
ED*4X36B**	*8MX*0451408**	0.99	0.99	EHD4X36A**	*9MPV075	0.99	0.95	EN(A,D,W)4X42*21**	*8MX*1102120**	1.00	0.96
ED*4X36B**	MV08B15**B*	0.99	0.95	EHD4X36A**	*9MPV100	0.99	0.95	EN(A,D,W)4X42*21**	NOMV156E19*	1.00	0.96
ED*4X36B**		0.99	0.99	EHD4X36A**	*9MPV125	0.99	0.95	EN(A,D,W)4X42*21**		1.00	1.00
ED*4X36F**	*8MPV075	0.99	0.95	EHD4X36A**	*9MVX040	0.99	0.99	END4X42*17**	*8MV*0901716**	1.00	0.96

> Indicates Tested Indoor Model

- continued on next page -

COOLING Multiplying Factors for other Indoor Combinations (continued)

Indoor Model	Furnace Model	Capac. (MBh)	Power (AMPS)	Indoor Model	Furnace Model	Capac. (MBh)	Power (AMPS)	Indoor Model	Furnace Model	Capac. (MBh)	Power (AMPS)
ED*4X36F**	*8MV*0901716**	0.99	0.95	EHD4X36A**	*9MVX060	0.99	0.95	END4X42*17**	*8MX*0701716**	1.00	0.96
ED*4X36F**	*8MX*0701716**	0.99	0.95	EHD4X36A**	*9MVX080	0.99	0.95	END4X42*17**	NOMV106D12*	1.00	0.96
ED*4X36F**	*9MPV050	0.99	0.99	EHD4X36A**	*9MVX100	0.99	0.95	END4X42*17**		1.00	1.00
ED*4X36F**	*9MPV075	0.99	0.99	EHD4X36A**	MV08B15**B*	0.99	0.95	ENH4X36*17**	*8MV*0701412**	0.99	0.95
ED*4X36F**	*9MVX040	0.99	0.99	EHD4X36A**	MV12F19**B*	0.99	0.91	ENH4X36*17**	*8MV*0901716**	0.99	0.95
ED*4X36F**	*9MVX060	0.99	0.99	EHD4X36A**	MV16J22**B*	0.99	0.91	ENH4X36*17**	*8MV*1102120**	0.99	0.95
ED*4X36F**	MV12F19**B*	0.99	0.95	EHD4X36A**	MV20L24**B*	0.99	0.91	ENH4X36*17**	*8MV*1352422**	0.99	0.95
ED*4X36F**	NOMV106D12*	0.99	0.95	EHD4X36A**	NOMV106D12*	1.00	0.96	ENH4X36*17**	*8MX*0451408**	0.99	0.99
ED*4X36F**		0.99	0.99	EHD4X36A**	NOMV156E19*	1.00	0.96	ENH4X36*17**	*8MX*0701716**	0.99	0.95
ED*4X36J**	*8MPV100	0.99	0.95	EHD4X36A**		0.99	0.99	ENH4X36*17**	*8MX*0902116**	0.99	0.95
ED*4X36J**	*8MPV125	0.99	0.95	EHD4X42A**	*8MPV050	1.00	1.00	ENH4X36*17**	*8MX*1102120**	0.99	0.95
ED*4X36J**	*8MV*1102120**	0.99	0.95	EHD4X42A**	*8MPV075	1.00	0.96	ENH4X36*17**	NOMV156E19*	0.99	0.95
ED*4X36J**	*8MX*0902116**	0.99	0.95	EHD4X42A**	*8MPV100	1.00	0.96	ENH4X36*17**		0.99	0.99
ED*4X36J**	*8MX*1102120**	0.99	0.95	EHD4X42A**	*8MPV125	1.00	0.96	ENH4X42*21**	*8MV*0701412**	1.00	0.96
ED*4X36J**	*9MPV100	0.99	0.95	EHD4X42A**	*8MV*0701412**	1.00	0.96	ENH4X42*21**	*8MV*0901716**	1.00	0.96
ED*4X36J**	*9MVX080	0.99	0.95	EHD4X42A**	*8MV*0901716**	1.00	0.96	ENH4X42*21**	*8MV*1102120**	1.00	0.96
ED*4X36J**	MV16J22**B*	0.99	0.95	EHD4X42A**	*8MV*1102120**	1.00	0.96	ENH4X42*21**	*8MV*1352422**	1.00	0.96
ED*4X36J**	NOMV156E19*	0.99	0.95	EHD4X42A**	*8MV*1352422**	1.00	0.96	ENH4X42*21**	*8MX*0451408**	1.00	1.00
ED*4X36J**		0.99	0.99	EHD4X42A**	*8MX*0451408**	1.00	1.00	ENH4X42*21**	*8MV*0701716**	1.00	0.96
ED*4X42F**	*8MPV075	1.00	0.96	EHD4X42A**	*8MX*0701716**	1.00	0.96	ENH4X42*21**	*8MX*0902116**	1.00	0.96
ED*4X42F**	*9MPV050	1.00	1.00	EHD4X42A**	*8MX*0902116**	1.00	0.96	ENH4X42*21**	*8MX*1102120**	1.00	0.96
ED*4X42F**	*9MPV075	1.00	1.00	EHD4X42A**	*8MX*1102120**	1.00	0.92	ENH4X42*21**	NOMV106D12*	0.99	0.95
ED*4X42F**	*9MVX040	1.00	1.00	EHD4X42A**	*9MPV050	1.00	1.00	ENH4X42*21**	NOMV156E19*	1.00	0.96
ED*4X42F**	*9MVX060	1.00	1.00	EHD4X42A**	*9MPV075	1.00	0.96	ENH4X42*21**		1.00	1.00
ED*4X42F**	MV12F19**B*	1.00	0.96	EHD4X42A**	*9MPV100	1.00	0.96	ENH4X43*21**	*8MV*0701412**	1.01	0.96
ED*4X42F**		1.00	1.00	EHD4X42A**	*9MPV125	1.00	0.96	ENH4X43*21**	*8MV*0901716**	1.01	0.92
ED*4X42J**	*8MPV100	1.00	0.96	EHD4X42A**	*9MVX040	1.00	1.00	ENH4X43*21**	*8MV*1102120**	1.01	0.92
ED*4X42J**	*8MPV125	1.00	0.96	EHD4X42A**	*9MVX060	1.00	0.96	ENH4X43*21**	*8MV*1352422**	1.01	0.92
ED*4X42J**	*8MV*1102120**	1.00	0.96	EHD4X42A**	*9MVX080	1.00	0.96	ENH4X43*21**	*8MX*0451408**	1.01	0.96
ED*4X42J**	*8MX*0902116**	1.00	0.96	EHD4X42A**	*9MVX100	1.00	0.96	ENH4X43*21**	*8MX*0701716**	1.01	0.96
ED*4X42J**	*8MX*1102120**	1.00	0.96	EHD4X42A**	MV08B15**B*	1.00	0.96	ENH4X43*21**	*8MX*0902116**	1.01	0.92
ED*4X42J**	*9MPV100	1.00	0.96	EHD4X42A**	MV12F19**B*	1.00	0.92	ENH4X43*21**	*8MX*1102120**	1.01	0.92
ED*4X42J**	*9MVX080	1.00	0.96	EHD4X42A**	MV16J22**B*	1.00	0.92	ENH4X43*21**	NOMV106D12*	1.00	0.96
ED*4X42J**	MV16J22**B*	1.00	0.96	EHD4X42A**	MV20L24**B*	1.00	0.92	ENH4X43*21**	NOMV156E19*	1.00	0.96
ED*4X42J**	NOMV156E19*	1.00	0.96	EHD4X42A**	NOMV106D12*	1.00	0.96	ENH4X43*21**		1.01	1.01
ED*4X42J**		1.00	1.00	EHD4X42A**	NOMV156E19*	1.00	0.96	FEA4X36**A*		1.00	1.00
ED*4X42L**	*8MV*1352422**	1.00	0.96	EHD4X42A**		1.00	1.00	FEM4P36**A*		1.00	1.00
ED*4X42L**	*9MPV125	1.00	0.96	EMA4X36D**		0.99	0.99	FEM4P36**A*		1.00	1.00
ED*4X42L**	*9MVX100	1.00	0.96	EN(A,D)4X36*21**	*8MV*1102120**	0.99	0.95	FEM4P42**A*		1.00	1.00
ED*4X42L**	MV20L24**B*	1.00	0.96	EN(A,D)4X36*21**	*8MX*0902116**	0.99	0.95	FEM4P42**A*		1.00	0.96
ED*4X42L**		1.00	1.00	EN(A,D)4X36*21**	*8MX*1102120**	0.99	0.95	FEM4X36****		1.00	0.96
EHD4X36A**	*8MPV050	0.99	0.99	EN(A,D)4X36*21**	NOMV156E19*	0.99	0.95	FEM4X42****		1.00	0.96
EHD4X36A**	*8MPV075	0.99	0.95	EN(A,D)4X36*21**		0.99	0.99	FS(M,U)4P36**A*		1.00	1.00
EHD4X36A**	*8MPV100	0.99	0.95	EN(A,D)4X37*17**	*8MV*0901716**	1.01	0.96	FS(M,U)4P42**A*		1.00	1.00

> Indicates Tested Indoor Model

- continued on next page -

COOLING Multiplying Factors for other Indoor Combinations (continued)

Indoor Model	Furnace Model	Capac. (MBh)	Power (AMPS)	Indoor Model	Furnace Model	Capac. (MBh)	Power (AMPS)	Indoor Model	Furnace Model	Capac. (MBh)	Power (AMPS)
EHD4X36A**	*8MPV125	0.99	0.95	EN(A,D)4X37*17**	*8MX*0701716**	1.01	0.96	FS(M,U)4P42**A*		1.00	1.00
EHD4X36A**	*8MV*0701412**	0.99	0.95	EN(A,D)4X37*17**	NOMV106D12*	1.00	0.96	FS(M,U)4X42****		1.00	1.00
EHD4X36A**	*8MV*0901716**	0.99	0.95	EN(A,D)4X37*17**		1.01	1.01	FSM4X36****		1.00	1.00
EHD4X36A**	*8MV*1102120**	0.99	0.95	EN(A,D)4X43*24**	*8MV*1352422**	1.01	0.96	FVM4X24****		1.00	0.96
EHD4X36A**	*8MV*1352422**	0.99	0.95	EN(A,D)4X43*24**		1.01	1.01	FVM4X36****		1.00	0.96
EHD4X36A**	*8MX*0451408**	0.99	0.99	EN(A,D,W)4X36*17**	*8MV*0901716**	0.99	0.95	FVM4X48****		1.01	0.92
EHD4X36A**	*8MX*0701716**	0.99	0.95	EN(A,D,W)4X36*17**	*8MX*0701716**	0.99	0.95	FXM4X36**A*		1.00	0.92
EHD4X36A**	*8MX*0902116**	0.99	0.95					FXM4X42**A*		1.00	0.92
H4H342											
>FS(M,U)4P42**A*		1.00	1.00								
ED*4X42F**	*8MPV075	0.98	0.98	EHD4X42A**	*8MX*0902116**	0.98	0.93	EN(A,D,W)4X48*21**	*8MX*1102120**	1.00	0.96
ED*4X42F**	MV12F19**B*	0.98	0.93	EHD4X42A**	*8MX*1102120**	0.98	0.93	EN(A,D,W)4X48*21**	NOMV156E19*	0.98	0.93
ED*4X42F**		0.98	0.98	EHD4X42A**	*8MX*1352420**	0.98	0.93	EN(A,D,W)4X48*21**		1.00	1.00
ED*4X42J**	*8MPV100	0.98	0.93	EHD4X42A**	*9MPV075	0.98	0.98	END4X42*17**	*8MV*0901716**	0.98	0.98
ED*4X42J**	*8MPV125	0.98	0.93	EHD4X42A**	*9MPV100	0.98	0.93	END4X42*17**	*8MX*0701716**	0.98	0.93
ED*4X42J**	*8MV*1102120**	0.98	0.93	EHD4X42A**	*9MPV125	0.98	0.93	END4X42*17**		0.98	0.98
ED*4X42J**	*8MX*0902116**	0.98	0.93	EHD4X42A**	*9MVX060	0.98	0.98	ENH4X42*21**	*8MV*0701412**	0.98	0.98
ED*4X42J**	*8MX*1102120**	0.98	0.93	EHD4X42A**	*9MVX080	0.98	0.93	ENH4X42*21**	*8MV*0901716**	0.98	0.93
ED*4X42J**	*9MPV100	0.98	0.93	EHD4X42A**	*9MVX100	0.98	0.93	ENH4X42*21**	*8MV*1102120**	0.98	0.93
ED*4X42J**	*9MVX080	0.98	0.93	EHD4X42A**	MV12F19**B*	0.98	0.93	ENH4X42*21**	*8MV*1352422**	0.98	0.93
ED*4X42J**	MV16J22**B*	0.98	0.93	EHD4X42A**	MV16J22**B*	0.98	0.93	ENH4X42*21**	*8MX*0701716**	0.98	0.98
ED*4X42J**	NOMV156E19*	0.96	0.92	EHD4X42A**	MV20L24**B*	0.98	0.93	ENH4X42*21**	*8MX*0902116**	0.98	0.93
ED*4X42J**		0.98	0.98	EHD4X42A**	NOMV156E19*	0.98	0.93	ENH4X42*21**	*8MX*1102120**	0.98	0.93
ED*4X42L**	*8MV*1352422**	0.98	0.93	EHD4X42A**		0.98	0.98	ENH4X42*21**	*8MX*1352420**	0.98	0.93
ED*4X42L**	*8MX*1352420**	0.98	0.93	EHD4X48A**	*8MPV075	1.00	0.96	ENH4X42*21**	NOMV156E19*	0.96	0.92
ED*4X42L**	*9MPV125	0.98	0.93	EHD4X48A**	*8MPV100	1.00	0.96	ENH4X42*21**		0.98	0.98
ED*4X42L**	*9MVX100	0.98	0.93	EHD4X48A**	*8MPV125	1.00	0.96	ENH4X43*21**	*8MV*0701412**	1.00	0.96
ED*4X42L**	MV20L24**B*	0.98	0.93	EHD4X48A**	*8MV*0701412**	1.00	0.96	ENH4X43*21**	*8MV*0901716**	1.00	0.96
ED*4X42L**		0.98	0.98	EHD4X48A**	*8MV*0901716**	1.00	0.96	ENH4X43*21**	*8MV*1102120**	1.00	0.96
ED*4X48F**	*8MPV075	1.00	0.96	EHD4X48A**	*8MV*1102120**	1.00	0.96	ENH4X43*21**	*8MV*1352422**	1.00	0.92
ED*4X48F**	*8MV*0901716**	1.00	0.96	EHD4X48A**	*8MV*1352422**	1.00	0.96	ENH4X43*21**	*8MX*0701716**	1.00	1.00
ED*4X48F**	*8MX*0701716**	1.00	0.96	EHD4X48A**	*8MX*0701716**	1.00	0.96	ENH4X43*21**	*8MX*0902116**	1.00	0.96
ED*4X48F**	*9MPV075	0.98	0.98	EHD4X48A**	*8MX*0902116**	1.00	0.96	ENH4X43*21**	*8MX*1102120**	1.00	0.92
ED*4X48F**	*9MVX060	1.00	1.00	EHD4X48A**	*8MX*1102120**	1.00	0.96	ENH4X43*21**	*8MX*1352420**	1.00	0.92
ED*4X48F**	MV12F19**B*	1.00	0.92	EHD4X48A**	*8MX*1352420**	1.00	0.96	ENH4X43*21**	NOMV156E19*	0.98	0.93
ED*4X48F**		1.00	1.00	EHD4X48A**	*9MPV075	1.00	1.00	ENH4X43*21**		1.00	1.00
ED*4X48J**	*8MPV100	1.00	0.96	EHD4X48A**	*9MPV100	1.00	0.96	ENH4X48*21**	*8MV*0701412**	0.98	0.93
ED*4X48J**	*8MPV125	1.00	0.96	EHD4X48A**	*9MPV125	1.00	0.96	ENH4X48*21**	*8MV*0901716**	1.00	0.96
ED*4X48J**	*8MV*1102120**	0.98	0.93	EHD4X48A**	*9MVX060	1.00	0.96	ENH4X48*21**	*8MV*1102120**	1.00	0.96
ED*4X48J**	*8MX*0902116**	1.00	0.96	EHD4X48A**	*9MVX080	1.00	0.96	ENH4X48*21**	*8MV*1352422**	1.00	0.96
ED*4X48J**	*8MX*1102120**	1.00	0.96	EHD4X48A**	*9MVX100	1.00	0.96	ENH4X48*21**	*8MX*0701716**	1.00	1.00
ED*4X48J**	*9MPV100	1.00	0.96	EHD4X48A**	MV12F19**B*	1.00	0.92	ENH4X48*21**	*8MX*0902116**	1.00	0.96
ED*4X48J**	*9MVX080	1.00	0.96	EHD4X48A**	MV16J22**B*	1.00	0.92	ENH4X48*21**	*8MX*1102120**	1.00	0.96

> Indicates Tested Indoor Model

- continued on next page -

COOLING Multiplying Factors for other Indoor Combinations (continued)

Indoor Model	Furnace Model	Capac. (MBh)	Power (AMPS)	Indoor Model	Furnace Model	Capac. (MBh)	Power (AMPS)	Indoor Model	Furnace Model	Capac. (MBh)	Power (AMPS)
ED*4X48J**	MV16J22**B*	1.00	0.96	EHD4X48A**	MV20L24**B*	1.00	0.92	ENH4X48*21**	*8MX*1352420**	1.00	0.96
ED*4X48J**	NOMV156E19*	0.98	0.93	EHD4X48A**	NOMV156E19*	0.98	0.93	ENH4X48*21**	NOMV156E19*	0.98	0.93
ED*4X48J**		1.00	1.00	EHD4X48A**		1.00	1.00	ENH4X48*21**		1.00	1.00
ED*4X48L**	*8MV*1352422**	1.00	0.96	EMA4X48D**		1.00	1.00	FEM4P42**A*		1.00	1.00
ED*4X48L**	*8MX*1352420**	1.00	0.96	EN(A,D)4X43*24**	*8MV*1352422**	1.00	0.92	FEM4P42**A*		1.00	0.96
ED*4X48L**	*9MPV125	1.00	0.96	EN(A,D)4X43*24**	*8MX*1352420**	1.00	0.92	FEM4P48**A*		1.00	1.00
ED*4X48L**	*9MVX100	1.00	0.96	EN(A,D)4X43*24**		1.00	1.00	FEM4P48**A*		1.00	0.96
ED*4X48L**	MV20L24**B*	1.00	0.96	EN(A,D)4X48*24**	*8MV*1352422**	1.00	0.96	FEM4X42****		1.00	0.96
ED*4X48L**		1.00	1.00	EN(A,D)4X48*24**	*8MX*1352420**	1.00	0.96	FEM4X48****		1.00	0.92
EHD4X42A**	*8MPV075	0.98	0.93	EN(A,D)4X48*24**		1.00	1.00	FS(M,U)4P42**A*		1.00	1.00
EHD4X42A**	*8MPV100	0.98	0.93	EN(A,D,W)4X42*21**	*8MV*1102120**	0.98	0.98	FS(M,U)4P48**A*		1.00	1.00
EHD4X42A**	*8MPV125	0.98	0.93	EN(A,D,W)4X42*21**	*8MX*0902116**	0.98	0.93	FS(M,U)4P48**A*		1.00	1.00
EHD4X42A**	*8MV*0701412**	0.98	0.98	EN(A,D,W)4X42*21**	*8MX*1102120**	0.98	0.93	FS(M,U)4X42****		0.98	0.98
EHD4X42A**	*8MV*0901716**	0.98	0.93	EN(A,D,W)4X42*21**	NOMV156E19*	0.96	0.92	FS(M,U)4X48****		1.00	1.00
EHD4X42A**	*8MV*1102120**	0.98	0.93	EN(A,D,W)4X42*21**		0.98	0.98	FVM4X36****		0.98	0.93
EHD4X42A**	*8MV*1352422**	0.98	0.93	EN(A,D,W)4X48*21**	*8MV*1102120**	1.00	0.96	FVM4X48****		1.00	0.92
EHD4X42A**	*8MX*0701716**	0.98	0.98	EN(A,D,W)4X48*21**	*8MX*0902116**	1.00	0.96	FXM4X42**A*		1.00	0.96
H4H348											
>FS(M,U)4P48**A*		1.00	1.00	EHD4X48A**	*8MV*1352422**	0.98	0.94	EN(A,D,W)4X60*24**	*8MX*1352420**	1.00	0.96
ED*4X48L**	*8MV*0901716**	0.98	0.94	EHD4X48A**	*8MX*0902116**	0.98	0.94	EN(A,D,W)4X60*24**		1.00	1.00
ED*4X48L**		0.98	0.98	EHD4X48A**	*8MX*1102120**	0.98	0.94	ENH4X48*21**	*8MV*0901716**	0.98	0.94
ED*4X48J**	*8MPV100	0.98	0.94	EHD4X48A**	*8MX*1352420**	0.98	0.94	ENH4X48*21**	*8MV*1102120**	0.98	0.94
ED*4X48J**	*8MPV125	0.98	0.94	EHD4X48A**	*9MPV100	0.98	0.94	ENH4X48*21**	*8MV*1352422**	0.98	0.94
ED*4X48J**	*8MV*1102120**	0.98	0.94	EHD4X48A**	*9MPV125	0.98	0.94	ENH4X48*21**	*8MX*0902116**	0.98	0.94
ED*4X48J**	*8MX*0902116**	0.98	0.94	EHD4X48A**	*9MVX080	0.98	0.94	ENH4X48*21**	*8MX*1102120**	0.98	0.94
ED*4X48J**	*8MX*1102120**	0.98	0.94	EHD4X48A**	*9MVX100	0.98	0.94	ENH4X48*21**	*8MX*1352420**	0.98	0.94
ED*4X48J**	*9MPV100	0.98	0.98	EHD4X48A**	MV16J22**B*	0.98	0.94	ENH4X48*21**	NOMV156E19*	0.98	0.94
ED*4X48J**	*9MVX080	0.98	0.98	EHD4X48A**	MV20L24**B*	0.98	0.94	ENH4X48*21**		0.98	0.98
ED*4X48J**	MV16J22**B*	0.98	0.94	EHD4X48A**	NOMV156E19*	0.98	0.94	ENH4X60*24**	*8MV*0901716**	1.00	0.96
ED*4X48J**	NOMV156E19*	0.98	0.94	EHD4X48A**		0.98	0.98	ENH4X60*24**	*8MV*1102120**	1.00	0.96
ED*4X48J**		0.98	0.98	EHD4X60A**	*8MPV100	1.00	0.96	ENH4X60*24**	*8MV*1352422**	1.00	0.96
ED*4X48L**	*8MV*1352422**	0.98	0.94	EHD4X60A**	*8MPV125	1.00	0.96	ENH4X60*24**	*8MX*0701716**	1.00	1.00
ED*4X48L**	*8MX*1352420**	0.98	0.94	EHD4X60A**	*8MV*0901716**	1.00	0.96	ENH4X60*24**	*8MX*0902116**	1.00	0.96
ED*4X48L**	*9MPV125	0.98	0.94	EHD4X60A**	*8MV*1102120**	1.00	0.96	ENH4X60*24**	*8MX*1102120**	1.00	0.96
ED*4X48L**	*9MVX100	0.98	0.94	EHD4X60A**	*8MV*1352422**	1.00	0.96	ENH4X60*24**	*8MX*1352420**	1.00	0.96
ED*4X48L**	MV20L24**B*	0.98	0.94	EHD4X60A**	*8MX*0701716**	1.00	1.00	ENH4X60*24**	NOMV156E19*	0.98	0.94
ED*4X48L**		0.98	0.98	EHD4X60A**	*8MX*0902116**	1.00	0.96	ENH4X60*24**		1.00	1.00
ED*4X60J**	*8MPV100	1.00	0.96	EHD4X60A**	*8MX*1102120**	1.00	0.96	ENH4X61*24**	*8MV*0901716**	1.00	0.96
ED*4X60J**	*8MPV125	1.00	0.96	EHD4X60A**	*8MX*1352420**	1.00	0.96	ENH4X61*24**	*8MV*1102120**	1.00	0.96
ED*4X60J**	*8MV*1102120**	1.00	0.96	EHD4X60A**	*9MPV100	1.00	0.96	ENH4X61*24**	*8MV*1352422**	1.00	0.96
ED*4X60J**	*8MX*0902116**	1.00	0.96	EHD4X60A**	*9MPV125	1.00	0.96	ENH4X61*24**	*8MX*0701716**	1.00	1.00
ED*4X60J**	*8MX*1102120**	1.00	0.96	EHD4X60A**	*9MVX080	1.00	0.96	ENH4X61*24**	*8MX*0902116**	1.00	0.96
ED*4X60J**	*9MPV100	1.00	0.96	EHD4X60A**	*9MVX100	1.00	0.96	ENH4X61*24**	*8MX*1102120**	1.00	0.96

> Indicates Tested Indoor Model

- continued on next page -

COOLING Multiplying Factors for other Indoor Combinations (continued)

Indoor Model	Furnace Model	Capac. (MBh)	Power (AMPS)	Indoor Model	Furnace Model	Capac. (MBh)	Power (AMPS)	Indoor Model	Furnace Model	Capac. (MBh)	Power (AMPS)
ED*4X60J**	*9MVX080	1.00	0.96	EHD4X60A**	MV16J22**B*	1.00	0.96	ENH4X61*24**	*8MX*1352420**	1.00	0.96
ED*4X60J**	MV16J22**B*	1.00	0.96	EHD4X60A**	MV20L24**B*	1.00	0.96	ENH4X61*24**	NOMV156E19*	1.00	0.96
ED*4X60J**	NOMV156E19*	0.98	0.94	EHD4X60A**	NOMV156E19*	1.00	0.96	ENH4X61*24**		1.00	1.00
ED*4X60J**		1.00	1.00	EHD4X60A**		1.00	1.00	FEM4P48**A*		0.98	0.98
ED*4X60L**	*8MV*1352422**	1.00	0.96	EN(A,D)4X48*24**	*8MV*1352422**	0.98	0.94	FEM4P48**A*		0.98	0.98
ED*4X60L**	*8MV*1352422**	1.00	0.96	EN(A,D)4X48*24**	*8MX*1352420**	0.98	0.94	FEM4P60**A*		1.00	1.00
ED*4X60L**	*8MX*1352420**	1.00	0.96	EN(A,D)4X48*24**		0.98	0.98	FEM4P60**A*		1.00	0.96
ED*4X60L**	*8MX*1352420**	1.00	0.96	EN(A,D)4X61*24**	*8MV*1352422**	1.00	0.96	FEM4X48****		1.00	0.96
ED*4X60L**	*9MPV125	1.00	0.96	EN(A,D)4X61*24**	*8MX*1352420**	1.00	0.96	FEM4X60****		1.00	0.96
ED*4X60L**	*9MVX100	1.00	0.96	EN(A,D)4X61*24**		1.00	1.00	FS(M,U)4P48**A*		1.00	1.00
ED*4X60L**	MV20L24**B*	1.00	0.96	EN(A,D,W)4X48*21**	*8MV*1102120**	0.98	0.94	FS(M,U)4X48****		0.98	0.98
ED*4X60L**		1.00	1.00	EN(A,D,W)4X48*21**	*8MX*0902116**	0.98	0.94	FS(M,U)4X60**A*		1.00	1.00
EHD4X48A**	*8MPV100	0.98	0.94	EN(A,D,W)4X48*21**	*8MX*1102120**	0.98	0.94	FVM4X48****		0.98	0.94
EHD4X48A**	*8MPV125	0.98	0.94	EN(A,D,W)4X48*21**	NOMV156E19*	0.98	0.94	FVM4X60****		1.00	0.92
EHD4X48A**	*8MV*0901716**	0.98	0.94	EN(A,D,W)4X48*21**		0.98	0.98	FXM4X48**A*		1.00	0.96
EHD4X48A**	*8MV*1102120**	0.98	0.94	EN(A,D,W)4X60*24**	*8MV*1352422**	1.00	0.96	FXM4X60**A*		1.00	0.92
H4H360											
>FS(M,U)4X60****		1.00	1.00	FVM4X60****		1.02	0.96	ENH4X60*24**	*8MV*1102120**	0.99	0.97
ED*4X60J**	*8MPV125	1.00	0.98	FXM4X60**A*		1.01	0.95	ENH4X60*24**	*8MV*1352422**	0.99	0.97
ED*4X60J**	*8MV*1102120**	0.99	0.97	EHD4X60A**	*8MX*0902116**	0.99	0.97	ENH4X60*24**	*8MX*0902116**	0.98	0.97
ED*4X60J**	*8MX*0902116**	0.99	0.97	EHD4X60A**	*8MX*1102120**	1.00	0.98	ENH4X60*24**	*8MX*1102120**	0.99	0.97
ED*4X60J**	*8MX*1102120**	1.00	0.98	EHD4X60A**	*8MX*1352420**	1.00	0.98	ENH4X60*24**	*8MX*1352420**	0.99	0.97
ED*4X60J**	MV16J22**B*	1.01	0.97	EHD4X60A**	MV16J22**B*	1.01	0.97	ENH4X60*24**		0.99	0.99
ED*4X60J**		0.99	0.99	EHD4X60A**	MV20L24**B*	1.01	0.97	ENH4X61*24**	*8MV*1102120**	1.00	0.98
ED*4X60L**	*8MV*1352422**	0.99	0.97	EHD4X60A**		1.00	1.00	ENH4X61*24**	*8MV*1352422**	1.00	0.98
ED*4X60L**	*8MX*1352420**	0.99	0.97	EN(A,D)4X61*24**	*8MV*1352422**	1.01	0.97	ENH4X61*24**	*8MX*1102120**	1.00	0.96
ED*4X60L**	MV20L24**B*	1.01	0.97	EN(A,D)4X61*24**	*8MX*1352420**	1.01	0.97	ENH4X61*24**	*8MX*1352420**	0.99	0.97
ED*4X60L**		0.99	0.99	EN(A,D)4X61*24**		1.01	0.99	ENH4X61*24**		1.00	0.98
EHD4X60A**	*8MPV125	1.00	0.98	EN(A,D,W)4X60*24**	*8MV*1352422**	0.99	0.97	FEM4X48****		0.98	0.97
EHD4X60A**	*8MV*1102120**	1.00	0.98	EN(A,D,W)4X60*24**	*8MX*1352420**	0.99	0.97	FEM4X60****		1.01	0.97
EHD4X60A**	*8MV*1352422**	1.00	0.96	EN(A,D,W)4X60*24**		0.99	0.99	FS(M,U)4X60**A*		1.00	1.00

> Indicates Tested Indoor Model

HEATING Multiplying Factors for other Indoor Combinations

Indoor Model	Furnace Model	Capac. (MBh)	Power (AMPS)	Indoor Model	Furnace Model	Capac. (MBh)	Power (AMPS)	Indoor Model	Furnace Model	Capac. (MBh)	Power (AMPS)
H4H330											
>FS(M,U)4P30**A*		1.00	1.00	EHD4X30A**	*8MX*0701716**	0.97	0.99	EN(A,D)4X36*21**	*8MV*1102120**	0.97	0.98
ED*4X30B**	*8MV*0701412**	0.97	1.00	EHD4X30A**	*8MX*0902116**	0.97	0.98	EN(A,D)4X36*21**	*8MX*0902116**	0.97	0.98
ED*4X30B**	MV08B15**B*	0.97	0.97	EHD4X30A**	*9MPV050	0.98	1.01	EN(A,D,W)4X36*17**	*8MV*0901716**	0.97	0.99
ED*4X30F**	*8MPV075	0.99	0.99	EHD4X30A**	*9MPV075	0.98	1.01	EN(A,D,W)4X36*17**	*8MX*0701716**	0.97	0.99
ED*4X30F**	*8MV*0901716**	0.97	0.99	EHD4X30A**	*9MPV100	0.98	0.99	ENH4X30*17**	*8MV*0701412**	0.97	0.99
ED*4X30F**	*8MX*0701716**	0.97	0.99	EHD4X30A**	*9MPV125	0.98	0.98	ENH4X30*17**	*8MV*0901716**	0.97	0.99
ED*4X30F**	*9MPV050	0.99	1.01	EHD4X30A**	*9MVX040	0.98	1.01	ENH4X30*17**	*8MV*1102120**	0.97	0.98
ED*4X30F**	*9MPV075	0.99	1.01	EHD4X30A**	*9MVX060	0.98	1.00	ENH4X30*17**	*8MV*1352422**	0.97	0.98
ED*4X30F**	*9MVX040	0.99	1.01	EHD4X30A**	*9MVX080	0.98	0.97	ENH4X30*17**	*8MX*0701716**	0.97	0.99
ED*4X30F**	*9MVX060	0.99	1.00	EHD4X30A**	*9MVX100	0.98	0.99	ENH4X30*17**	*8MX*0902116**	0.97	0.98
ED*4X30F**	MV12F19**B*	0.98	0.97	EHD4X30A**	MV08B15**B*	0.98	0.97	ENH4X36*17**	*8MV*0701412**	0.97	0.99
ED*4X36B**	*8MV*0701412**	0.97	0.99	EHD4X30A**	MV12F19**B*	0.98	0.97	ENH4X36*17**	*8MV*0901716**	0.97	0.99
ED*4X36B**	MV08B15**B*	0.98	0.98	EHD4X36A**	*8MPV050	1.00	0.98	ENH4X36*17**	*8MV*1102120**	0.97	0.98
ED*4X36F**	*8MPV075	0.98	0.97	EHD4X36A**	*8MPV075	0.99	0.95	ENH4X36*17**	*8MV*1352422**	0.97	0.98
ED*4X36F**	*8MV*0901716**	0.97	0.98	EHD4X36A**	*8MPV100	0.99	0.94	ENH4X36*17**	*8MX*0701716**	0.97	0.99
ED*4X36F**	*8MX*0701716**	0.97	0.98	EHD4X36A**	*8MPV125	0.99	0.94	ENH4X36*17**	*8MX*0902116**	0.97	0.98
ED*4X36F**	*9MPV050	0.98	1.00	EHD4X36A**	*8MV*0701412**	0.97	0.96	FEA4X30**A*		1.00	1.00
ED*4X36F**	*9MPV075	0.98	0.99	EHD4X36A**	*8MV*0901716**	0.97	0.96	FEA4X36**A*		1.00	1.00
ED*4X36F**	*9MVX040	0.98	1.00	EHD4X36A**	*8MV*1102120**	0.97	0.95	FEM4P30**A*		1.00	1.00
ED*4X36F**	*9MVX060	0.98	0.98	EHD4X36A**	*8MV*1352422**	0.97	0.95	FEM4P30**A*		1.00	1.00
ED*4X36F**	MV12F19**B*	0.98	0.97	EHD4X36A**	*8MX*0701716**	0.97	0.95	FEM4P36**A*		1.00	1.00
ED*4X36F**	NOMV106D12*	0.97	0.99	EHD4X36A**	*8MX*0902116**	0.97	0.94	FEM4P36**A*		1.00	1.00
ED*4X36J**	*8MPV100	0.98	0.95	EHD4X36A**	*9MPV050	0.99	0.98	FEM4X30****		0.99	0.98
ED*4X36J**	*8MPV125	0.98	0.95	EHD4X36A**	*9MPV075	0.99	0.97	FEM4X36****		0.97	0.94
ED*4X36J**	*8MV*1102120**	0.97	0.98	EHD4X36A**	*9MPV100	0.99	0.95	FS(M,U)4P30**A*		1.00	1.00
ED*4X36J**	*8MX*0902116**	0.97	0.96	EHD4X36A**	*9MPV125	0.99	0.95	FVM4X24****		0.98	0.97
ED*4X36J**	*9MPV100	0.98	0.96	EHD4X36A**	*9MVX040	0.99	0.98	FVM4X36****		0.97	0.96
ED*4X36J**	*9MVX080	0.98	0.95	EHD4X36A**	*9MVX060	0.99	0.96	FVM4X48****		0.98	0.93
EHD4X30A**	*8MPV050	0.98	1.00	EHD4X36A**	*9MVX080	0.99	0.94	FXM4X30**A*		0.97	0.95
EHD4X30A**	*8MPV075	0.98	0.99	EHD4X36A**	*9MVX100	0.99	0.95	FXM4X36**A*		0.97	0.92
EHD4X30A**	*8MPV100	0.98	0.98	EHD4X36A**	MV08B15**B*	0.98	0.95				
EHD4X30A**	*8MPV125	0.98	0.98	EHD4X36A**	MV12F19**B*	0.98	0.94				
EHD4X30A**	*8MV*0701412**	0.97	0.99	EHD4X36A**	NOMV106D12*	0.97	0.97				
EHD4X30A**	*8MV*0901716**	0.97	0.99	EN(A,D)4X30*14**	*8MV*0701412**	0.97	1.00				
EHD4X30A**	*8MV*1102120**	0.97	0.98	EN(A,D)4X30*17**	*8MV*0901716**	0.97	0.99				
EHD4X30A**	*8MV*1352422**	0.97	0.98	EN(A,D)4X30*17**	*8MX*0701716**	0.97	0.99				
H4H336											
>FS(M,U)4P36**A*		1.00	1.00	EHD4X36A**	*9MPV050	0.97	0.97	EN(A,D,W)4X36*17**		0.99	1.01
ED*4X36B**	*8MPV050	0.97	1.01	EHD4X36A**	*8MX*1102120**	0.99	0.94	EN(A,D,W)4X42*21**	*8MV*1102120**	0.99	0.97
ED*4X36B**	*8MV*0701412**	0.99	1.00	EHD4X36A**	*9MPV050	0.97	0.97	EN(A,D,W)4X42*21**	*8MX*0902116**	0.99	0.96
ED*4X36B**	*8MX*0451408**	0.99	1.02	EHD4X36A**	*9MPV075	0.97	0.96	EN(A,D,W)4X42*21**	*8MV*1102120**	0.99	0.95
ED*4X36B**	MV08B15**B*	0.97	0.96	EHD4X36A**	*9MPV100	0.97	0.93	EN(A,D,W)4X42*21**	NOMV156E19*	0.97	0.96

> Indicates Tested Indoor Model

- continued on next page -

HEATING Multiplying Factors for other Indoor Combinations (continued)

Indoor Model	Furnace Model	Capac. (MBh)	Power (AMPS)	Indoor Model	Furnace Model	Capac. (MBh)	Power (AMPS)	Indoor Model	Furnace Model	Capac. (MBh)	Power (AMPS)
ED*4X36B**		0.99	1.02	EHD4X36A**	*9MPV125	0.97	0.92	EN(A,D,W)4X42*21**		0.99	1.00
ED*4X36F**	*8MPV075	0.97	0.97	EHD4X36A**	*9MVX040	0.97	0.97	END4X42*17**	*8MV*0901716**	0.99	0.96
ED*4X36F**	*8MV*0901716**	0.97	0.97	EHD4X36A**	*9MVX060	0.97	0.95	END4X42*17**	*8MX*0701716**	0.99	0.97
ED*4X36F**	*8MX*0701716**	0.99	1.00	EHD4X36A**	*9MVX080	0.97	0.92	END4X42*17**	NOMV106D12*	0.97	0.96
ED*4X36F**	*9MPV050	0.97	1.00	EHD4X36A**	*9MVX100	0.97	0.93	END4X42*17**		0.99	0.98
ED*4X36F**	*9MPV075	0.97	0.99	EHD4X36A**	MV08B15**B*	0.97	0.93	ENH4X36*17**	*8MV*0701412**	0.97	0.99
ED*4X36F**	*9MVX040	0.97	1.00	EHD4X36A**	MV12F19**B*	0.97	0.92	ENH4X36*17**	*8MV*0901716**	0.97	0.98
ED*4X36F**	*9MVX060	0.97	0.98	EHD4X36A**	MV16J22**B*	0.97	0.92	ENH4X36*17**	*8MV*1102120**	0.97	0.98
ED*4X36F**	MV12F19**B*	0.97	0.95	EHD4X36A**	MV20L24**B*	0.97	0.92	ENH4X36*17**	*8MV*1352422**	0.97	0.97
ED*4X36F**	NOMV106D12*	0.97	0.99	EHD4X36A**	NOMV106D12*	0.97	0.96	ENH4X36*17**	*8MX*0451408**	0.99	1.02
ED*4X36F**		0.99	1.01	EHD4X36A**	NOMV156E19*	0.97	0.95	ENH4X36*17**	*8MX*0701716**	0.99	1.01
ED*4X36J**	*8MPV100	0.97	0.94	EHD4X36A**		0.99	0.98	ENH4X36*17**	*8MX*0902116**	0.97	0.97
ED*4X36J**	*8MPV125	0.97	0.94	EHD4X42A**	*8MPV050	0.97	0.96	ENH4X36*17**	*8MX*1102120**	0.97	0.96
ED*4X36J**	*8MV*1102120**	0.97	0.96	EHD4X42A**	*8MPV075	0.97	0.92	ENH4X36*17**	NOMV156E19*	0.97	0.98
ED*4X36J**	*8MX*0902116**	0.99	0.97	EHD4X42A**	*8MPV100	0.97	0.90	ENH4X36*17**		0.99	1.01
ED*4X36J**	*8MX*1102120**	0.99	0.96	EHD4X42A**	*8MPV125	0.97	0.89	ENH4X42*21**	*8MV*0701412**	0.97	0.97
ED*4X36J**	*9MPV100	0.97	0.95	EHD4X42A**	*8MV*0701412**	0.99	0.96	ENH4X42*21**	*8MV*0901716**	0.97	0.96
ED*4X36J**	*9MVX080	0.97	0.95	EHD4X42A**	*8MV*0901716**	0.99	0.95	ENH4X42*21**	*8MV*1102120**	0.97	0.95
ED*4X36J**	MV16J22**B*	0.97	0.94	EHD4X42A**	*8MV*1102120**	0.99	0.94	ENH4X42*21**	*8MV*1352422**	0.97	0.95
ED*4X36J**	NOMV156E19*	0.97	0.97	EHD4X42A**	*8MV*1352422**	0.99	0.94	ENH4X42*21**	*8MX*0451408**	0.97	0.98
ED*4X36J**		1.00	1.02	EHD4X42A**	*8MX*0451408**	0.99	0.96	ENH4X42*21**	*8MX*0701716**	0.97	0.97
ED*4X42F**	*8MPV075	0.97	0.95	EHD4X42A**	*8MX*0701716**	0.99	0.95	ENH4X42*21**	*8MX*0902116**	0.97	0.94
ED*4X42F**	*9MPV050	0.97	0.98	EHD4X42A**	*8MX*0902116**	0.99	0.93	ENH4X42*21**	*8MX*1102120**	0.97	0.94
ED*4X42F**	*9MPV075	0.97	0.97	EHD4X42A**	*8MX*1102120**	0.99	0.92	ENH4X42*21**	NOMV106D12*	0.97	0.97
ED*4X42F**	*9MVX040	0.97	0.99	EHD4X42A**	*9MPV050	0.97	0.95	ENH4X42*21**	NOMV156E19*	0.97	0.96
ED*4X42F**	*9MVX060	0.97	0.97	EHD4X42A**	*9MPV075	0.97	0.94	ENH4X42*21**		0.99	1.00
ED*4X42F**	MV12F19**B*	0.97	0.94	EHD4X42A**	*9MPV100	0.97	0.91	ENH4X43*21**	*8MV*0701412**	0.99	0.93
ED*4X42F**		0.99	1.00	EHD4X42A**	*9MPV125	0.97	0.90	ENH4X43*21**	*8MV*0901716**	0.99	0.92
ED*4X42J**	*8MPV100	0.97	0.93	EHD4X42A**	*9MVX040	0.97	0.95	ENH4X43*21**	*8MV*1102120**	0.99	0.91
ED*4X42J**	*8MPV125	0.97	0.92	EHD4X42A**	*9MVX060	0.97	0.93	ENH4X43*21**	*8MV*1352422**	0.99	0.91
ED*4X42J**	*8MV*1102120**	0.97	0.95	EHD4X42A**	*9MVX080	0.97	0.90	ENH4X43*21**	*8MX*0451408**	0.99	0.94
ED*4X42J**	*8MX*0902116**	0.99	0.96	EHD4X42A**	*9MVX100	0.97	0.91	ENH4X43*21**	*8MX*0701716**	0.99	0.92
ED*4X42J**	*8MX*1102120**	0.99	0.95	EHD4X42A**	MV08B15**B*	0.97	0.91	ENH4X43*21**	*8MX*0902116**	0.99	0.90
ED*4X42J**	*9MPV100	0.97	0.94	EHD4X42A**	MV12F19**B*	0.97	0.91	ENH4X43*21**	*8MX*1102120**	0.99	0.89
ED*4X42J**	*9MVX080	0.97	0.94	EHD4X42A**	MV16J22**B*	0.97	0.90	ENH4X43*21**	NOMV106D12*	0.97	0.92
ED*4X42J**	MV16J22**B*	0.97	0.93	EHD4X42A**	MV20L24**B*	0.97	0.91	ENH4X43*21**	NOMV156E19*	0.97	0.91
ED*4X42J**	NOMV156E19*	0.97	0.96	EHD4X42A**	NOMV106D12*	0.97	0.95	ENH4X43*21**		0.99	0.95
ED*4X42J**		0.99	1.00	EHD4X42A**	NOMV156E19*	0.97	0.94	FEA4X36**A*		1.00	1.02
ED*4X42L**	*8MV*1352422**	0.97	0.95	EHD4X42A**		0.97	0.94	FEM4P36**A*		1.00	1.00
ED*4X42L**	*9MPV125	0.97	0.93	EMA4X36D**		0.99	1.01	FEM4P36**A*		1.00	1.00
ED*4X42L**	*9MVX100	0.97	0.94	EN(A,D)4X36*21**	*8MV*1102120**	0.97	0.97	FEM4P42**A*		1.00	0.94
ED*4X42L**	MV20L24**B*	0.97	0.93	EN(A,D)4X36*21**	*8MX*0902116**	0.97	0.97	FEM4P42**A*		1.00	0.94
ED*4X42L**		0.97	0.98	EN(A,D)4X36*21**	*8MX*1102120**	0.97	0.96	FEM4X36****		0.99	0.94
EHD4X36A**	*8MPV050	0.99	1.00	EN(A,D)4X36*21**	NOMV156E19*	0.97	0.98	FEM4X42****		1.00	0.95

> Indicates Tested Indoor Model

- continued on next page -

HEATING Multiplying Factors for other Indoor Combinations (continued)

Indoor Model	Furnace Model	Capac. (MBh)	Power (AMPS)	Indoor Model	Furnace Model	Capac. (MBh)	Power (AMPS)	Indoor Model	Furnace Model	Capac. (MBh)	Power (AMPS)
EHD4X36A**	*8MPV075	0.97	0.94	EN(A,D)4X36*21**		0.99	1.01	FS(M,U)4P36**A*		1.00	1.00
EHD4X36A**	*8MPV100	0.97	0.91	EN(A,D)4X37*17**	*8MV*0901716**	0.99	0.92	FS(M,U)4P42**A*		1.00	0.97
EHD4X36A**	*8MPV125	0.97	0.91	EN(A,D)4X37*17**	*8MX*0701716**	0.99	0.93	FS(M,U)4P42**A*		0.99	0.96
EHD4X36A**	*8MV*0701412**	0.99	0.97	EN(A,D)4X37*17**	NOMV106D12*	0.97	0.92	FS(M,U)4X42****		1.00	1.00
EHD4X36A**	*8MV*0901716**	0.99	0.96	EN(A,D)4X37*17**		0.99	0.95	FSM4X36****		1.00	0.99
EHD4X36A**	*8MV*1102120**	0.99	0.95	EN(A,D)4X43*24**	*8MV*1352422**	0.99	0.91	FVM4X24****		0.97	0.96
EHD4X36A**	*8MV*1352422**	0.99	0.95	EN(A,D)4X43*24**		0.99	0.95	FVM4X36****		0.97	0.95
EHD4X36A**	*8MX*0451408**	0.99	0.98	EN(A,D,W)4X36*17**	*8MV*0901716**	0.97	0.98	FVM4X48****		0.97	0.90
EHD4X36A**	*8MX*0701716**	0.99	0.97	EN(A,D,W)4X36*17**	*8MX*0701716**	0.99	1.01	FXM4X36**A*		1.00	0.93
EHD4X36A**	*8MX*0902116**	0.99	0.94	EN(A,D,W)4X36*17**	NOMV106D12*	0.97	1.00	FXM4X42**A*		1.00	0.93
EHD4X36A**	*8MX*1102120**	0.99	0.94								
H4H342											
>FS(M,U)4P42**A*		1.00	1.00	EHD4X42A**	*8MX*0902116**	0.96	0.95	EN(A,D,W)4X48*21**	NOMV156E19*	0.96	0.96
ED*4X42F**	*8MPV075	0.96	0.99	EHD4X42A**	*8MX*1102120**	0.96	0.94	EN(A,D,W)4X48*21**		0.99	0.99
ED*4X42F**	MV12F19**B*	0.96	0.97	EHD4X42A**	*8MX*1352420**	0.96	0.95	END4X42*17**	*8MV*0901716**	0.96	0.97
ED*4X42F**		1.00	1.03	EHD4X42A**	*8MPV075	0.99	1.01	END4X42*17**	*8MX*0701716**	0.96	0.99
ED*4X42J**	*8MPV100	0.96	0.96	EHD4X42A**	*9MPV100	0.99	0.97	END4X42*17**		0.99	1.00
ED*4X42J**	*8MPV125	0.96	0.96	EHD4X42A**	*9MPV125	0.99	0.97	ENH4X42*21**	*8MV*0701412**	0.96	1.00
ED*4X42J**	*8MV*1102120**	0.96	0.98	EHD4X42A**	*9MVX060	0.99	1.00	ENH4X42*21**	*8MV*0901716**	0.96	0.99
ED*4X42J**	*8MX*0902116**	0.96	0.98	EHD4X42A**	*9MVX080	0.99	0.97	ENH4X42*21**	*8MV*1102120**	0.96	0.98
ED*4X42J**	*8MX*1102120**	0.96	0.97	EHD4X42A**	*9MVX100	0.99	0.97	ENH4X42*21**	*8MV*1352422**	0.96	0.98
ED*4X42J**	*9MPV100	0.96	0.98	EHD4X42A**	MV12F19**B*	0.96	0.93	ENH4X42*21**	*8MX*0701716**	0.96	1.00
ED*4X42J**	*9MVX080	0.99	1.00	EHD4X42A**	MV16J22**B*	0.96	0.93	ENH4X42*21**	*8MX*0902116**	0.96	0.98
ED*4X42J**	MV16J22**B*	0.96	0.96	EHD4X42A**	MV20L24**B*	0.96	0.93	ENH4X42*21**	*8MX*1102120**	0.96	0.98
ED*4X42J**	NOMV156E19*	0.96	0.99	EHD4X42A**	NOMV156E19*	0.96	0.96	ENH4X42*21**	*8MX*1352420**	0.96	0.98
ED*4X42J**		0.99	1.02	EHD4X42A**		0.99	0.99	ENH4X42*21**	NOMV156E19*	0.96	0.99
ED*4X42L**	*8MV*1352422**	0.96	0.97	EHD4X48A**	*8MPV075	0.99	0.98	ENH4X42*21**		0.96	0.99
ED*4X42L**	*8MX*1352420**	0.96	0.97	EHD4X48A**	*8MPV100	0.99	0.95	ENH4X43*21**	*8MV*0701412**	0.96	0.95
ED*4X42L**	*9MPV125	0.96	0.97	EHD4X48A**	*8MPV125	0.99	0.95	ENH4X43*21**	*8MV*0901716**	0.96	0.93
ED*4X42L**	*9MVX100	0.96	0.97	EHD4X48A**	*8MV*0701412**	0.96	0.96	ENH4X43*21**	*8MV*1102120**	0.96	0.93
ED*4X42L**	MV20L24**B*	0.96	0.96	EHD4X48A**	*8MV*0901716**	0.96	0.95	ENH4X43*21**	*8MV*1352422**	0.96	0.92
ED*4X42L**		0.99	1.02	EHD4X48A**	*8MV*1102120**	0.96	0.94	ENH4X43*21**	*8MX*0701716**	0.98	0.96
ED*4X48F**	*8MPV075	0.99	0.98	EHD4X48A**	*8MV*1352422**	0.96	0.94	ENH4X43*21**	*8MX*0902116**	0.98	0.94
ED*4X48F**	*8MV*0901716**	0.96	0.95	EHD4X48A**	*8MX*0701716**	0.99	0.99	ENH4X43*21**	*8MX*1102120**	0.98	0.93
ED*4X48F**	*8MX*0701716**	0.99	0.99	EHD4X48A**	*8MX*0902116**	0.96	0.94	ENH4X43*21**	*8MX*1352420**	0.98	0.93
ED*4X48F**	*9MPV075	0.99	1.00	EHD4X48A**	*8MX*1102120**	0.96	0.94	ENH4X43*21**	NOMV156E19*	0.96	0.94
ED*4X48F**	*9MVX060	0.99	0.99	EHD4X48A**	*8MX*1352420**	0.96	0.94	ENH4X43*21**		0.96	0.95
ED*4X48F**	MV12F19**B*	0.96	0.92	EHD4X48A**	*9MPV075	0.99	1.00	ENH4X48*21**	*8MV*0701412**	0.96	0.97
ED*4X48F**		0.99	0.98	EHD4X48A**	*9MPV100	0.99	0.97	ENH4X48*21**	*8MV*0901716**	0.96	0.95
ED*4X48J**	*8MPV100	0.99	0.96	EHD4X48A**	*9MPV125	0.99	0.96	ENH4X48*21**	*8MV*1102120**	0.96	0.95
ED*4X48J**	*8MPV125	0.99	0.96	EHD4X48A**	*9MVX060	0.99	0.99	ENH4X48*21**	*8MV*1352422**	0.96	0.94
ED*4X48J**	*8MV*1102120**	0.96	0.95	EHD4X48A**	*9MVX080	0.99	0.96	ENH4X48*21**	*8MX*0701716**	0.96	0.97
ED*4X48J**	*8MX*0902116**	0.96	0.95	EHD4X48A**	*9MVX100	0.99	0.97	ENH4X48*21**	*8MX*0902116**	0.96	0.94
ED*4X48J**	*8MX*1102120**	0.96	0.94	EHD4X48A**	MV12F19**B*	0.96	0.93	ENH4X48*21**	*8MX*1102120**	0.96	0.94

> Indicates Tested Indoor Model

- continued on next page -

HEATING Multiplying Factors for other Indoor Combinations (continued)

Indoor Model	Furnace Model	Capac. (MBh)	Power (AMPS)	Indoor Model	Furnace Model	Capac. (MBh)	Power (AMPS)	Indoor Model	Furnace Model	Capac. (MBh)	Power (AMPS)
ED*4X48J**	*9MPV100	0.99	0.98	EHD4X48A**	MV16J22**B*	0.96	0.92	ENH4X48*21**	*8MX*1352420**	0.96	0.94
ED*4X48J**	*9MVX080	0.99	0.97	EHD4X48A**	MV20L24**B*	0.96	0.92	ENH4X48*21**	NOMV156E19*	0.96	0.96
ED*4X48J**	MV16J22**B*	0.96	0.93	EHD4X48A**	NOMV156E19*	0.96	0.95	ENH4X48*21**		0.99	0.99
ED*4X48J**	NOMV156E19*	0.96	0.96	EHD4X48A**		0.99	0.98	FEM4P42**A*		0.99	0.98
ED*4X48J**		0.99	0.99	EMA4X48D**		0.99	1.00	FEM4P42**A*		0.99	0.98
ED*4X48L**	*8MV*1352422**	0.96	0.94	EN(A,D)4X43*24**	*8MV*1352422**	0.96	0.92	FEM4P48**A*		0.99	0.97
ED*4X48L**	*8MX*1352420**	0.96	0.94	EN(A,D)4X43*24**	*8MX*1352420**	0.98	0.93	FEM4P48**A*		0.98	0.96
ED*4X48L**	*9MPV125	0.99	0.97	EN(A,D)4X43*24**		0.99	0.97	FEM4X42****		0.98	0.97
ED*4X48L**	*9MVX100	0.99	0.97	EN(A,D)4X48*24**	*8MV*1352422**	0.96	0.94	FEM4X48****		0.99	0.95
ED*4X48L**	MV20L24**B*	0.96	0.93	EN(A,D)4X48*24**	*8MX*1352420**	0.96	0.94	FS(M,U)4P42**A*		1.00	1.00
ED*4X48L**		0.99	0.99	EN(A,D)4X48*24**		0.99	0.99	FS(M,U)4P48**A*		0.99	0.97
EHD4X42A**	*8MPV075	0.99	0.98	EN(A,D,W)4X42*21**	*8MV*1102120**	0.96	0.98	FS(M,U)4P48**A*		0.99	0.97
EHD4X42A**	*8MPV100	0.99	0.96	EN(A,D,W)4X42*21**	*8MX*0902116**	0.96	0.98	FS(M,U)4X42****		0.99	1.02
EHD4X42A**	*8MPV125	0.99	0.96	EN(A,D,W)4X42*21**	*8MX*1102120**	0.96	0.98	FS(M,U)4X48****		0.99	0.99
EHD4X42A**	*8MV*0701412**	0.96	0.97	EN(A,D,W)4X42*21**	NOMV156E19*	0.96	0.99	FVM4X36****		0.96	0.98
EHD4X42A**	*8MV*0901716**	0.96	0.95	EN(A,D,W)4X42*21**		0.99	1.02	FVM4X48****		0.96	0.93
EHD4X42A**	*8MV*1102120**	0.96	0.95	EN(A,D,W)4X48*21**	*8MV*1102120**	0.96	0.95	FXM4X42**A*		0.99	0.97
EHD4X42A**	*8MV*1352422**	0.96	0.94		*8MX*0902116**	0.96	0.94	FXM4X48**A*		0.99	0.94
EHD4X42A**	*8MX*0701716**	0.96	0.97	EN(A,D,W)4X48*21**	*8MX*1102120**	0.96	0.94				
H4H348											
>FS(M,U)4P48**A*		1.00	1.00	EHD4X48A**	*8MX*0902116**	0.97	0.98	ENH4X48*21**	*8MV*0901716**	0.97	0.99
ED*4X48F**	*8MV*0901716**	0.97	0.99	EHD4X48A**	*8MX*1102120**	0.97	0.97	ENH4X48*21**	*8MV*1102120**	0.97	0.99
ED*4X48F**		1.00	1.03	EHD4X48A**	*8MX*1352420**	0.97	0.98	ENH4X48*21**	*8MV*1352422**	0.97	0.98
ED*4X48J**	*8MPV100	0.97	0.98	EHD4X48A**	*9MPV100	0.97	0.98	ENH4X48*21**	*8MX*0902116**	0.97	0.98
ED*4X48J**	*8MPV125	0.97	0.98	EHD4X48A**	*9MPV125	0.97	0.98	ENH4X48*21**	*8MX*1102120**	0.97	0.97
ED*4X48J**	*8MV*1102120**	0.97	0.99	EHD4X48A**	*9MVX080	0.97	0.98	ENH4X48*21**	*8MX*1352420**	0.97	0.98
ED*4X48J**	*8MX*0902116**	0.97	0.99	EHD4X48A**	*9MVX100	0.97	0.98	ENH4X48*21**	NOMV156E19*	0.97	0.99
ED*4X48J**	*8MX*1102120**	0.97	0.98	EHD4X48A**	MV16J22**B*	0.97	0.95	ENH4X48*21**		1.00	1.02
ED*4X48J**	*9MPV100	0.97	0.99	EHD4X48A**	MV20L24**B*	0.97	0.95	ENH4X60*24**	*8MV*0901716**	0.97	0.98
ED*4X48J**	*9MVX080	0.97	0.99	EHD4X48A**	NOMV156E19*	0.97	0.99	ENH4X60*24**	*8MV*1102120**	0.97	0.98
ED*4X48J**	MV16J22**B*	0.97	0.96	EHD4X48A**		1.00	1.01	ENH4X60*24**	*8MV*1352422**	0.97	0.97
ED*4X48J**	NOMV156E19*	0.97	1.00	EHD4X60A**	*8MPV100	0.97	0.95	ENH4X60*24**	*8MX*0701716**	0.97	1.01
ED*4X48J**		1.00	1.02	EHD4X60A**	*8MPV125	0.97	0.94	ENH4X60*24**	*8MX*0902116**	0.97	0.97
ED*4X48L**	*8MV*1352422**	0.97	0.98	EHD4X60A**	*8MV*0901716**	0.97	0.97	ENH4X60*24**	*8MX*1102120**	0.97	0.96
ED*4X48L**	*8MX*1352420**	0.97	0.98	EHD4X60A**	*8MV*1102120**	0.97	0.97	ENH4X60*24**	*8MX*1352420**	0.97	0.96
ED*4X48L**	*9MPV125	0.97	0.98	EHD4X60A**	*8MV*1352422**	0.97	0.96	ENH4X60*24**	NOMV156E19*	0.97	0.98
ED*4X48L**	*9MPV100	0.97	0.99	EHD4X60A**	*8MX*0701716**	0.97	1.00	ENH4X60*24**		1.00	1.01
ED*4X48L**	MV20L24**B*	0.97	0.96	EHD4X60A**	*8MX*0902116**	0.97	0.96	ENH4X61*24**	*8MV*0901716**	0.97	0.97
ED*4X48L**		1.00	1.02	EHD4X60A**	*8MX*1102120**	0.97	0.95	ENH4X61*24**	*8MV*1102120**	0.97	0.97
ED*4X60J**	*8MPV100	0.97	0.96	EHD4X60A**	*8MX*1352420**	0.97	0.95	ENH4X61*24**	*8MV*1352422**	0.97	0.96
ED*4X60J**	*8MPV125	0.97	0.96	EHD4X60A**	*9MPV100	0.97	0.96	ENH4X61*24**	*8MX*0701716**	0.97	1.00
ED*4X60J**	*8MV*1102120**	0.97	0.98	EHD4X60A**	*9MPV125	0.97	0.96	ENH4X61*24**	*8MX*0902116**	0.97	0.96
ED*4X60J**	*8MX*0902116**	0.97	0.97	EHD4X60A**	*9MVX080	0.97	0.96	ENH4X61*24**	*8MX*1102120**	0.97	0.95

> Indicates Tested Indoor Model

- continued on next page -

HEATING Multiplying Factors for other Indoor Combinations (continued)

Indoor Model	Furnace Model	Capac. (MBh)	Power (AMPS)	Indoor Model	Furnace Model	Capac. (MBh)	Power (AMPS)	Indoor Model	Furnace Model	Capac. (MBh)	Power (AMPS)
ED*4X60J**	*8MX*1102120**	0.97	0.96	EHD4X60A**	*9MVX100	0.97	0.96	ENH4X61*24**	*8MX*1352420**	0.97	0.96
ED*4X60J**	*9MPV100	0.97	0.98	EHD4X60A**	MV16J22**B*	0.97	0.94	ENH4X61*24**	NOMV156E19*	0.97	0.97
ED*4X60J**	*9MVX080	0.97	0.98	EHD4X60A**	MV20L24**B*	0.97	0.94	ENH4X61*24**		1.00	1.00
ED*4X60J**	MV16J22**B*	0.97	0.95	EHD4X60A**	NOMV156E19*	0.97	0.97	FEM4P48**A*		0.97	0.99
ED*4X60J**	NOMV156E19*	0.97	0.98	EHD4X60A**		1.00	1.00	FEM4P48**A*		0.97	0.99
ED*4X60J**		1.00	1.01	EN(A,D)4X48*24**	*8MV*1352422**	0.97	0.98	FEM4P60**A*		0.99	0.98
ED*4X60L**	*8MV*1352422**	0.97	0.97	EN(A,D)4X48*24**	*8MX*1352420**	0.97	0.98	FEM4P60**A*		0.99	0.98
ED*4X60L**	*8MV*1352422**	0.97	0.97	EN(A,D)4X48*24**		1.00	1.02	FEM4X48****		1.00	0.99
ED*4X60L**	*8MX*1352420**	0.97	0.97	EN(A,D)4X61*24**	*8MV*1352422**	0.97	0.94	FEM4X60****		0.99	0.95
ED*4X60L**	*8MX*1352420**	0.97	0.97	EN(A,D)4X61*24**	*8MX*1352420**	0.97	0.94	FS(M,U)4P48**A*		0.97	0.97
ED*4X60L**	*9MPV125	0.97	0.97	EN(A,D)4X61*24**		1.00	0.99	FS(M,U)4X48****		0.97	1.00
ED*4X60L**	*9MVX100	0.97	0.97	EN(A,D,W)4X48*21**	*8MV*1102120**	0.97	0.99	FS(M,U)4X60**A*		1.00	1.01
ED*4X60L**	MV20L24**B*	0.97	0.95	EN(A,D,W)4X48*21**	*8MX*0902116**	0.97	0.98	FVM4X48****		0.97	0.96
ED*4X60L**		1.00	1.01	EN(A,D,W)4X48*21**	*8MX*1102120**	0.97	0.97	FVM4X60****		0.97	0.93
EHD4X48A**	*8MPV100	0.97	0.97	EN(A,D,W)4X48*21**	NOMV156E19*	0.97	0.99	FXM4X48**A*		0.97	0.95
EHD4X48A**	*8MPV125	0.97	0.97	EN(A,D,W)4X48*21**		1.00	1.02	FXM4X60**A*		0.99	0.94
EHD4X48A**	*8MV*0901716**	0.97	0.99	EN(A,D,W)4X60*24**	*8MV*1352422**	0.97	0.97				
EHD4X48A**	*8MV*1102120**	0.97	0.98	EN(A,D,W)4X60*24**	*8MX*1352420**	0.97	0.96				
EHD4X48A**	*8MV*1352422**	0.97	0.97	EN(A,D,W)4X60*24**		1.00	1.01				

H4H360

>FS(M,U)4X60****		1.00	1.00	EHD4X60A**	*8MX*0902116**	0.99	0.99	ENH4X60*24**	*8MX*0902116**	0.99	1.02
ED*4X60J**	*8MPV125	0.99	0.98	EHD4X60A**	*8MX*1102120**	0.99	0.98	ENH4X60*24**	*8MX*1102120**	0.99	1.00
ED*4X60J**	*8MV*1102120**	0.99	0.99	EHD4X60A**	*8MX*1352420**	0.99	0.99	ENH4X60*24**	*8MX*1352420**	0.99	1.01
ED*4X60J**	*8MX*0902116**	0.98	0.99	EHD4X60A**	MV16J22**B*	0.99	0.96	ENH4X60*24**		1.00	1.02
ED*4X60J**	*8MX*1102120**	0.98	0.97	EHD4X60A**	MV20L24**B*	0.99	0.95	ENH4X61*24**	*8MV*1102120**	0.99	0.99
ED*4X60J**	MV16J22**B*	0.98	0.96	EHD4X60A**		1.00	1.00	ENH4X61*24**	*8MV*1352422**	0.98	0.97
ED*4X60J**		0.99	0.99	EN(A,D)4X61*24**	*8MV*1352422**	0.99	0.96	ENH4X61*24**	*8MX*1102120**	0.98	0.97
ED*4X60L**	*8MV*1352422**	0.98	0.98	EN(A,D)4X61*24**	*8MX*1352420**	0.99	0.97	ENH4X61*24**	*8MX*1352420**	0.98	0.98
ED*4X60L**	*8MX*1352420**	0.98	0.99	EN(A,D)4X61*24**		1.00	0.98	ENH4X61*24**		0.99	0.98
ED*4X60L**	MV20L24**B*	0.98	0.96	EN(A,D,W)4X60*24**	*8MV*1352422**	0.99	1.00	FEM4X48****		0.99	1.01
ED*4X60L**		0.99	0.99	EN(A,D,W)4X60*24**	*8MX*1352420**	0.99	1.01	FEM4X60****		0.98	0.95
EHD4X60A**	*8MPV125	1.01	0.99	EN(A,D,W)4X60*24**		1.00	1.02	FS(M,U)4X60**A*		1.00	1.00
EHD4X60A**	*8MV*1102120**	1.00	1.00	ENH4X60*24**	*8MV*1102120**	0.99	1.01	FVM4X60****		0.98	0.94
EHD4X60A**	*8MV*1352422**	0.99	0.98	ENH4X60*24**	*8MV*1352422**	0.99	1.00	FXM4X60**A*		0.98	0.94

> Indicates Tested Indoor Model

NOTE: This illustration is for reference only. Your unit may differ in appearance or may not include all components shown. Please refer to Parts List for exact parts listing.

208/230 Volts 3Phase

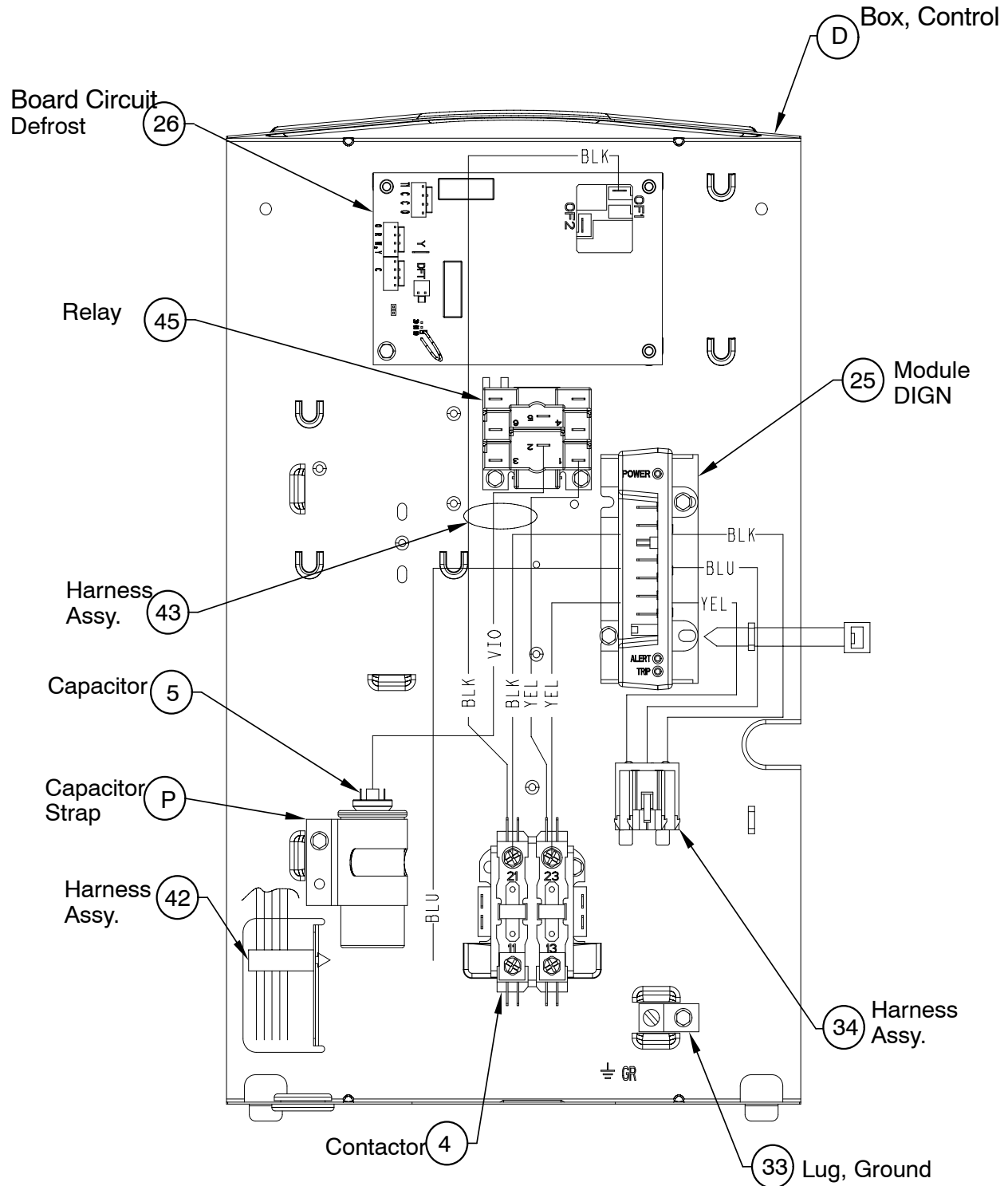

NOTE: This illustration is for reference only. Your unit may differ in appearance or may not include all components shown. Please refer to Parts List for exact parts listing.

460 Volt 3Phase

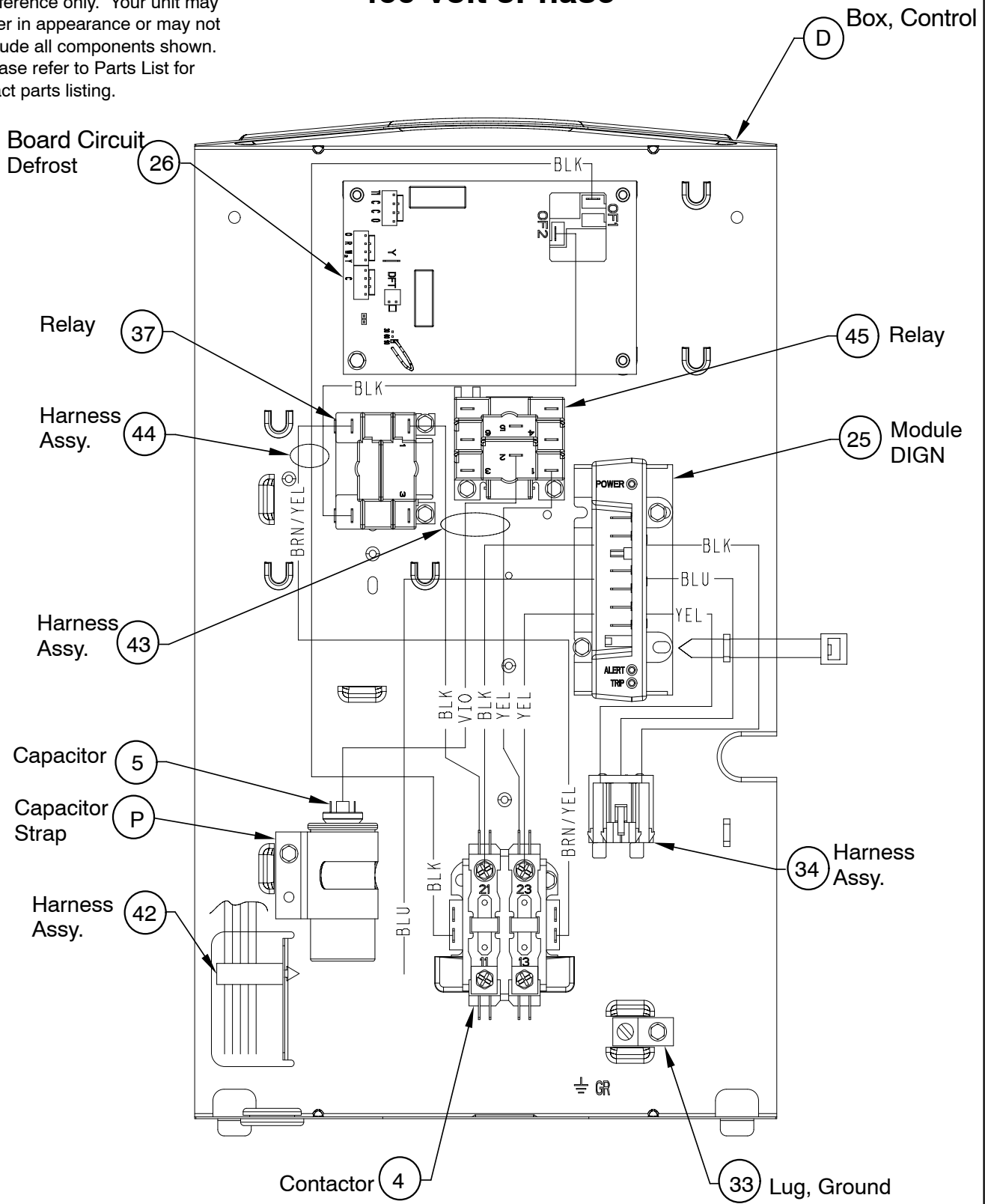

NOTE: This illustration is for reference only. Your unit may differ in appearance or may not include all components shown. Please refer to Parts List for exact parts listing.

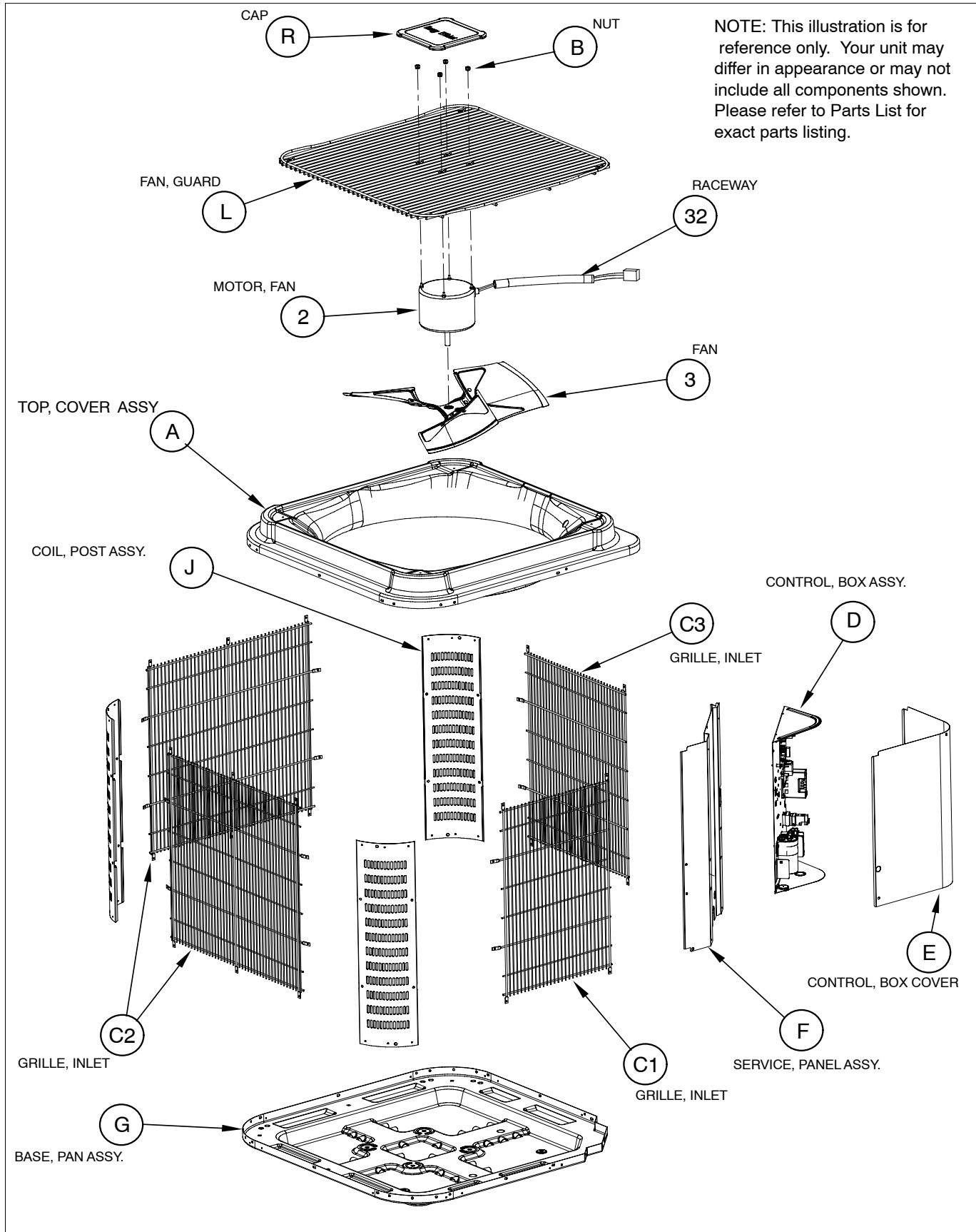

NOTE: This illustration is for reference only. Your unit may differ in appearance or may not include all components shown. Please refer to Parts List for exact parts listing.

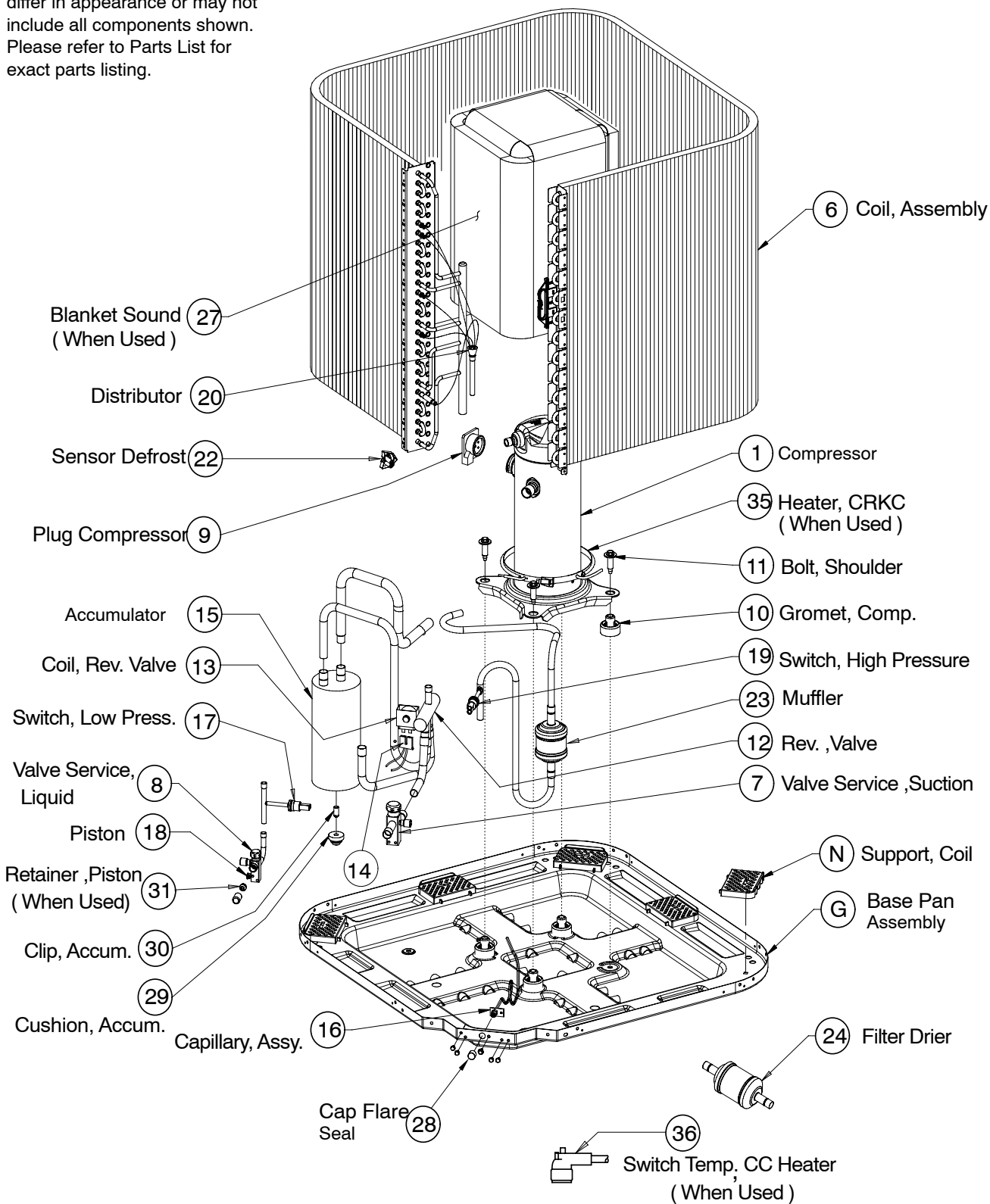

H4H3 PARTS LIST										
KEY NO.	DESCRIPTION	FAST PARTS NO.	H4H330GHE100	H4H336GHE100	H4H336GLE100	H4H342GHE100	H4H348GHE100	H4H348GLE100	H4H360GHD200	H4H360GLD200
01	COMPRESSOR	ZP28K5ETF5130	1	-	-	-	-	-	-	-
01	COMPRESSOR	ZP31K5ETF5130	-	1	-	-	-	-	-	-
01	COMPRESSOR	ZP31K5ETFD130			1				-	
01	COMPRESSOR	ZP38K5ETF5130	-	-	-	1	-	-	-	-
01	COMPRESSOR	ZP42K5ETF5130	-	-	-	-	1	-	-	-
01	COMPRESSOR	ZP42K5ETFD130						1		-
01	COMPRESSOR	ZP54K5ETF5130						-	1	-
01	COMPRESSOR	ZP54K5ETFD130						-	-	1
02	FAN MOTOR 1/5 HP	1177911	1	1	-	-	-	-	-	-
02	FAN MOTOR 1/10 HP	1177913	-	-	-	1	-	-	-	-
02	FAN MOTOR 1/4HP	1177912	-	-	-	-	1	-	-	-
02	FAN MOTOR 1/5 HP	1178563			1				-	
02	FAN MOTOR 1/4HP	1178564						1		-
02	FAN MOTOR 1/4HP	1177473						-	1	-
02	FAN MOTOR 1/4HP	1178541						-	-	1
03	FAN C 24" 3B 1/2" 24 INT	1177890	1	1	1	-	-	-	-	-
03	FAN C 24" 3B 1/2" 18 INT	1172715	-	-	-	1	-	-	-	-
03	FAN C 24" 3B 1/2"	1177891	-	-	-	-	1	1	-	-
03	FAN C 26" 3B 1/2" 24 INT	1172716	-	-	-	-	-	-	1	1
04	CONTACTOR 2P 30A	1173785	1	1	1	1	1	1	-	-
04	CONTACTOR 2P 30A 24V	1173786	-	-	-	-	-	-	1	1
05	CAP RN RD 370V 5	1171727	1	1	1	1	1	1	1	1
06	COND COIL ASSY	1179831	1	-	-	-	-	-	-	-
06	COND COIL ASSY	1179832	-	1	1	-	-	-	-	-
06	COND COIL ASSY	1179833	-	-	-	1	-	-	-	-
06	COND COIL ASSY	1179834	-	-	-	-	1	1	-	-
06	COND COIL REPLACEMENT KIT	1175512	-	-	-	-	-	-	1	1
07	VALVE SVC PARK SUC 12S-12S	1172726	1	1	1	-	-	-	-	-
07	VALVE SVC PARK SUC 14S-14S	1172727	-	-	-	1	1	1	1	1
08	VALVE SERVICE LIQUID	1173629	1	1	1	1	1	1	1	1
09	PLUG COMP WIRE (SM) 12GAx58"	1174687	1	1	1	1	1	1	1	1
10	GROMMET COMPRESSOR 1.62"DIA	1171270	4	4	4	4	4	4	4	4
11	BOLT SHLDR COMP. MTG,	1173630	4	4	4	4	4	4	4	4
12	VALVE REVERSING	1175621	1	1	1	-	-	-	-	-
12	VALVE REVERSING	1175622	-	-	-	1	1	1	1	1
13	COIL REV VLV 24V	1172574	1	1	1	1	1	1	1	1
14	HARNESS ASSY 52" RVS PLUG	1179387	1	1	1	1	1	1	-	-
14	HARNESS ASSY 52" RVS PLUG	1173988	-	-	-	-	-	-	1	1
15	ACCUMULATOR 120 3/4 NH	1172018	1	1	1	-	-	-	-	-
15	ACCUMULATOR	1172122	-	-	-	1	-	-	-	-
15	ACCUMULATOR	1173719	-	-	-	-	1	1	1	1
16	CAPILLARY ASSY FORMED	1174096	1	1	1	1	1	1	1	1
17	PRESSURE SWITCH LOW	1177594	1	1	1	1	1	1	-	-
17	PRESSURE SWITCH LOW	1176661	-	-	-	-	-	-	1	1
18	PISTON .055	1173655	1	-	-	-	-	-	-	-
18	PISTON CHATLEFF .057	1173658	-	1	1	-	-	-	-	-
18	PISTON CHATLEFF .065	1173873	-	-	-	1	1	1	1	1
19	SWITCH PRESSURE HIGH	1174695	1	1	1	1	1	1	1	1
20	DISTRIBUTOR	1172021	1	-	-	-	-	-	-	-

H4H3 PARTS LIST (continued)										
KEY NO.	DESCRIPTION	FAST PARTS NO.	H4H330GHE100	H4H336GHE100	H4H336GLE100	H4H342GHE100	H4H348GHE100	H4H348GLE100	H4H360GHD200	H4H360GLD200
20	DISTRIBUTOR	1172022	-	1	1	1	-	-	-	-
20	DISTRIBUTOR	1176638	-	-	-	-	1	1	1	1
22	SENSOR DEFROST O65 C32	1173637	1	1	1	1	1	1	1	1
23	MUFFLER	1173668	1	1	1	1	1	1	1	1
24	FILTER DRIER ASSY	1174010	1	1	1	1	1	1	1	1
25	MODULE COMP DIAGNOSTICS	1175688	1	1	1	1	1	1	1	1
26	DEFROST CONTROL BOARD	1173636	1	1	1	1	1	1	1	1
27	JACKET SOUND	1172015	1	-	-	-	-	-	-	-
27	JACKET SOUND	1172014	-	1	1	1	1	1	1	1
29	GROMMET ACCUMULATOR CUSHION	1172806	1	1	1	1	1	1	1	1
30	CLIP ACCUM	1173640	1	1	1	1	1	1	1	1
32	RACEWAY	1175919	1	1	1	1	1	1	1	1
33	LUG GROUND	1172300	1	1	1	1	1	1	1	1
34	HARNESS ASSY PLUG & PLAY	1175684	1	1	1	1	1	1	1	1
35	HTR CC WP 40W240V TCH-245	1174709	1	1	-	-	-	-	-	-
35	HTR CC WP 40W240V	1173944				1	1	-	1	-
35	HTR CC WP 40W460V	1175078			1				-	
35	HTR CC WP 40W460V	1175514						1		1
36	SWITCH TEMP DISC O85 C65	1173669	1	1	-	1	1	-	1	-
37	RELAY SPST 6FLA 24V	1174099			1			1	-	1
42	HARNESS ASY	1178519	1	1	1	1	1	1	1	1
44	HARNESS ASSY 3 PHASE HP 460V	1178542			1			1	-	1
A	TOP COVER ASY	1177914	1	1	1	1	1	1	-	-
A	TOP COVER ASY	1178327	-	-	-	-	-	-	1	1
B	NUT HEX 8-32 KNURL MTR MTG	1172217	4	4	4	4	4	4	4	4
C1	GRILLE INLET	1177419	1	-	-	1	-	-	-	-
C1	GRILLE INLET	1176706	-	1	1	-	-	-	-	-
C1	GRILLE INLET	1176433	-	-	-	-	1	1	-	-
C1	GRILLE INLET	1177492	-	-	-	-	-	-	1	1
C2	GRILLE INLET	1177969	2	-	-	2	-	-	-	-
C2	GRILLE INLET HEIL	1175806	-	2	2	-	-	-	-	-
C2	GRILLE INLET HEIL	1177978	-	-	-	-	2	2	-	-
C2	GRILLE INLET HEIL	1176701	-	-	-	-	-	-	1	1
C3	GRILLE INLET	1177972	1	-	-	1	-	-	-	-
C3	GRILLE INLET	1178060	-	1	1	-	-	-	-	-
C3	GRILLE INLET	1177981	-	-	-	-	1	1	-	-
C3	GRILLE INLET	1177495	-	-	-	-	-	-	1	1
D	BOX CONTROL	1173643	1	1	1	1	1	1	1	1
E	KIT COVER CONTROL BOX	1183101	1	-	-	-	-	-	-	-
E	KIT COVER CONTROL BOX	1183102	-	1	-	-	-	-	-	-
E	KIT COVER CONTROL BOX	1183103	-	-	-	1	-	-	-	-
E	KIT COVER CONTROL BOX	1183104	-	-	-	-	1	-	-	-
E	KIT COVER CONTROL BOX	1183105			1				-	
E	KIT COVER CONTROL BOX	1183106						1		-
E	KIT COVER CONTROL BOX	1178527						-	1	-
E	KIT COVER CONTROL BOX	1178544						-	-	1
F	SVCE PNL ASSY	1178324	1	-	-	1	-	-	1	1
F	SVCE PNL ASSY	1178528	-	1	1	-	-	-	-	-
F	SVCE PNL ASSY	1178325					1	1		-

H4H3 PARTS LIST (continued)										
KEY NO.	DESCRIPTION	FAST PARTS NO.	H4H330GHE100	H4H336GHE100	H4H336GLE100	H4H342GHE100	H4H348GHE100	H4H348GLE100	H4H360GHD200	H4H360GLD200
G	BASE PAN ASSY	1178308	1	1	1	1	1	1	-	-
G	BASE PAN ASSY	1178309	-	-	-	-	-	-	1	1
J	COR POST ASSY	1178312	3	-	-	3	-	-	3	3
J	COR POST ASSY	1178529	-	3	3	-	-	-	-	-
J	COR POST ASSY	1178313					3	3		-
L	FAN GUARD	1177893	1	1	1	1	1	1	-	-
L	FAN GUARD	1174032	-	-	-	-	-	-	1	1
N	SUPPORT COIL	1174068	5	5	5	5	5	5	5	5
P	CLAMP CAPACITOR ROUND	1174073	1	1	1	1	1	1	1	1
R	MOTOR CAP ASSY HEIL/MAIN AC&HP	1174729	1	1	1	1	1	1	1	1
Parts Not Shown										
)	KIT ADAPTER ASSY	1174192	1	1	1	1	1	1	1	1
)	GROMMET	1171737	1	1	1	1	1	1	1	1
)	DRIER BIFLOW 06 CI 3/8 SWEAT	1172311	1	1	1	1	1	1	1	1
)	DRIER FILTER SUCT LINE 8.0 CI	1174194	1	1	1	-	-	-	-	-
)	DRIER FILTER SUCT LINE 15.0 CI	1174193	-	-	-	1	1	1	1	1
)	WIRE HARNESS ASY COMFORT ALERT	1174728	1	1	1	1	1	1	-	-
)	CAP SERVICE KIT 11/16-20	1175650	1	1	1	1	1	1	1	1
)	CAP SERVICE KIT 15/16-20	1175651	1	1	1	-	-	-	-	-
)	CAP SERVICE KIT 1-1/16-20	1175652	-	-	-	1	1	1	1	1
)	CAP FLARE	1172410	1	1	1	1	1	1	1	1
)	KIT PISTON TOOL BODY RESIZER	1175477	1	1	1	1	1	1	1	1
)	PAINT TOUCH UP BALTIC GRY 1 PT	1178322	1	1	1	1	1	1	1	1
)	SCREW HEX HD 10AB X 3/8	1176782	44	44	44	44	44	44	44	44
)	SCREW BLK HEX 12AB 5/8	1178279	4	4	4	4	4	4	4	4
)	SCREW HX HEAD 10AB 1/2	1178280	12	12	12	12	12	12	12	12