

SERVICE AND MAINTENANCE INSTRUCTIONS

HORIZONTAL FAN COIL UNITS

FMU4X, FMU4Z, FMC4X, FMC4Z

NOTE: Read the entire instruction manual before starting the installation.

TABLE OF CONTENTS

	PAGE
SAFETY CONSIDERATIONS	1
INTRODUCTION	1
FAN COIL DESCRIPTION AND TROUBLESHOOTING .	1
MULTI-SPEED ECM FAN MOTOR	2
FAN SPEED SELECTION	2
FAN MOTOR	2
ELECTRIC HEATER SERVICE	2
SEQUENCE OF OPERATION	2
ELECTRIC HEATER FUNCTION AND TROUBLESHOOTING	2
DESCRIPTION OF ELECTRIC HEATER COMPONENTS CARE AND MAINTENANCE	6
AIR FILTER	6
COOLING COIL, DRAIN PAN, AND CONDENSATE DRAIN	6
DISCONNECTING THE CONTROL BOX ASSEMBLY .	6
FMC4X & FMU4X – DISCONNECTING THE BLOWER ASSEMBLY	6
FMC4X & FMU4X – SERVICING THE FAN MOTOR	7
FMC4Z & FMU4Z – DISCONNECTING THE BLOWER ASSEMBLY	9
FMC4Z & FMU4Z – SERVICING THE FAN MOTOR	10
CLEANING THE A-COIL	11
REMOVING THE DRAIN PAN	11
CHANGING THE A-COIL	12
REFRIGERANT METERING DEVICE	12

SAFETY CONSIDERATIONS

Improper installation, adjustment, alteration, service, maintenance, or use can cause explosion, fire, electrical shock, or other conditions which may cause death, personal injury or property damage. Consult a qualified installer, service agency, or your distributor or branch for information or assistance. The qualified installer or agency must use factory-authorized kits or accessories when modifying this product. Refer to the individual instructions packaged with kits or accessories when installing.

Follow all safety codes. Wear safety glasses, protective clothing and work gloves. Have a fire extinguisher available. Read these instructions thoroughly and follow all warnings or cautions included in literature and attached to the unit. Consult local building codes and the current editions of the National Electrical Code (NEC) NFPA 70.

In Canada, refer to the current editions of the Canadian Electrical Code CSA C22.1.

Recognize safety information. This is the safety-alert symbol . When you see this symbol on the unit and in instruction manuals, be alert to the potential for personal injury.

Understand the signal words **DANGER**, **WARNING**, and **CAUTION**. These words are used with the safety-alert symbol. **DANGER** identifies the most serious hazards which

will result in severe personal injury or death. **WARNING** signifies hazards which **could** result in personal injury or death. **CAUTION** is used to identify unsafe practices which **may** result in minor personal injury or product and property damage. **NOTE** is used to highlight suggestions which will result in enhanced installation, reliability, or operation.

 **WARNING**

UNIT OPERATION AND SAFETY HAZARD

Failure to follow this warning could result in personal injury or death.

R-410A systems operate at higher pressures than R-22 systems. Do not use R-22 service equipment or components on R-410A equipment. Ensure service equipment is rated for R-410A.

INTRODUCTION

FMC4X, FMC4Z, FMU4X, FMU4Z Fan Coils are designed for horizontal orientation and are suitable for ceiling installations. The FMC4X, FMC4Z models are cased and configured from the factory for bottom return applications. FMU4X, FMU4Z models are uncased. All units are available with field-installed electric heat. Units are used indoors as the fan coil for split-system heat pumps or air conditioners.

The coil is equipped with sweat-type connections and is vapor-charged with dry nitrogen.

Units are designed for horizontal applications only. Local codes may limit this free-air-return type unit to installation in single-level applications.

FAN COIL DESCRIPTION AND TROUBLESHOOTING

 **WARNING**

ELECTRICAL OPERATION HAZARD

Failure to follow this warning could result in personal injury or death.

Before installation or servicing system, always turn off main power to system. There may be more than one disconnect switch. Turn off accessory heater power if applicable. Lock out and tag switch with a suitable warning label.

MULTI-SPEED ECM FAN MOTOR

The multi-speed ECM motor used with this product contains two parts: the control module and the motor winding section.

- A.** It is normal for the motor to rock back and forth on startup. Do not replace the motor if this is the only problem identified.
- B.** If the motor is not running:
 1. Check for proper high voltage and ground at the L,G, and N connections at the motor. Correct any voltage issue before proceeding to the next step.
 2. The motor is communicated through 24-Vac signals to the 1,2,3,4,5 and C (common) terminals. Verify the part number of the motor matches the correct replacement motor part number for the unit model number.
 3. Initiate a demand from the thermostat and check the voltage between C (common) and terminal 1- 5. If voltage is present and the motor isn't operating, then the motor/control module is failed.

Fan Speed Selection

The fan speed selection is done at the motor connector. Units with or without electric heaters require a minimum CFM. Refer to the unit wiring label to ensure that the fan speed selected is not lower than the minimum fan speed indicated.

Table 1 – FMC4Z & FMU4Z ECM Motor Speed Taps

Tap	Delay-off Time(s)	18	24	30	36
Tap 1	90	Default			
Tap 2	90		Default		
Tap 3	90			Default	
Tap 4	90				Default
Tap 5	90				

FAN MOTOR

The motor is three-speed direct drive. High-speed lead is black, medium-speed lead is red, low-speed lead is blue, and common lead is purple. Be sure proper blower speed has been selected.

The motor is turned on through two different routes. The first occurs when thermostat calls for the fan in cooling, heat pump, or fan-only mode. A 24-Vac signal is sent to relay, causing relay to close its normally open contacts, turning fan on.

The second occurs when there is a call for electric heat. A 24-Vac signal is sent to heater sequencer/relay, causing it to close, directing 230V through the normally closed contact of fan relay, turning fan on. The fan remains on until sequencer/relay opens.

If motor does run, test motor for an open winding or a winding shorted to motor case. If either is present, replace motor.

ELECTRIC HEATER SERVICE

Service can be completed with heater in place. Shut off power before servicing.

A. Limit Switch

Refer to Electric Heater Kit Function and Troubleshooting section of this manual.

B. Relay

Refer to Electric Heater Kit Function and Troubleshooting section of this manual.

C. Transformer

A 40-VA transformer supplies 24-V power for control circuit. Check for 208/230V on primary side of transformer. If present, check for 24V on secondary side.

NOTE: Transformer is fused. Do not short circuit.

D. Fan Relay

Relay coil is 24-V. Check for proper control voltage. Replace relay if faulty.

SEQUENCE OF OPERATION

A. Condensing Unit

COOLING

When thermostat calls for cooling, the circuit between R and G is complete and FR is energized. The normally open contacts close causing blower to operate.

The circuit between R and Y is also complete. This completed circuit causes contactor in outdoor unit to close which starts compressor and outdoor fan.

HEATING

When thermostat calls for heating and FAN switch is set on AUTO, the circuit between R and W is complete. The heater relay is energized which closes contacts of relay. This completed circuit energizes all heating elements HTR and blower motor.

B. Heat Pump

COOLING

On a call for cooling, the thermostat makes circuits R-O, R-Y, and R-G. Circuit R-O energizes reversing valve, switching it to cooling position. Circuit R-Y energizes contactor starting outdoor fan motor and compressor. Circuit R-G energizes indoor unit blower relay starting indoor blower motor.

When thermostat is satisfied, its contacts open de-energizing contactor reversing valve and blower relay. This stops compressor and fan motors.

HEATING

On a call for heating, the thermostat makes circuits R-Y and R-G. Circuit R-Y energizes contactor starting outdoor fan motor and compressor. Circuit R-G energizes indoor blower relay starting blower motor.

Should temperature continue to fall, R-W circuit is made through second-stage room thermostat bulb. Circuit R-W energizes a relay bringing on supplemental electric heat.

Circuit R-W also energizes the compressor lockout relay which breaks the R-Y circuit. This prevents the simultaneous operation of the heat pump and electric heater.

When thermostat is satisfied, its contacts open, de-energizing contactor and relay. All heaters and motors should stop.

ELECTRIC HEATER FUNCTION AND TROUBLESHOOTING

This section describes EHK3 series electric heaters by examining functional operation of this heater.

Service can be completed with heater in place. Shut off power before servicing.

DESCRIPTION OF ELECTRIC HEATER COMPONENTS

A. Limit Switch

The limit switch is a temperature sensitive control that's function is to prevent system from overheating in abnormal conditions. The temperature settings often vary from heater to heater due to variations in airflow patterns and element radiant heat conditions.

The devices are sized to remain on-line under heat pump conditions (115°F air off coil) and minimum CFM, but trip to prevent outlet air conditions above 200°F or excessive component or duct temperatures. The device itself consists of a bimetallic disc, which when overheated “snaps through” to open a normally closed high-voltage, high-current switch. When system temperatures cool sufficiently, the switch will automatically reset to its closed position. Normal failure mode for this switch is open.

If a limit switch has been determined to be defective, NEVER BYPASS THE LIMIT SWITCH. When replacing limit switch,

ensure that it is replaced with a limit switch of identical opening temperature and closing differential. Limits switches are typically color-coded to identify their range.

B. Relay

The relays used on these heat kits utilize rectifier boards that sit atop the double pole relays. The rectifier board converts the 24AC signal into a DC current to drive relay. This heater control system does not incorporate any time delays. The fan motor is interconnected to one of the heater elements, this ensures fan operation during heater operation.

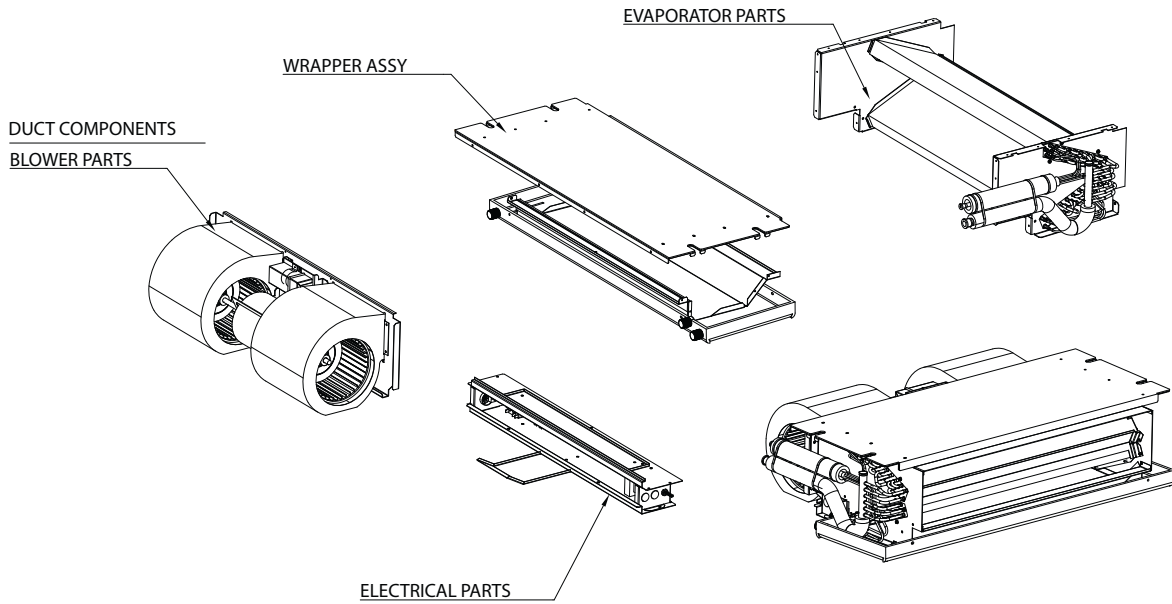

NOTE: This illustration is for reference only. Unit may differ in appearance or may not include all components shown.

Figure 1 – PSC Expanded Parts

A180050

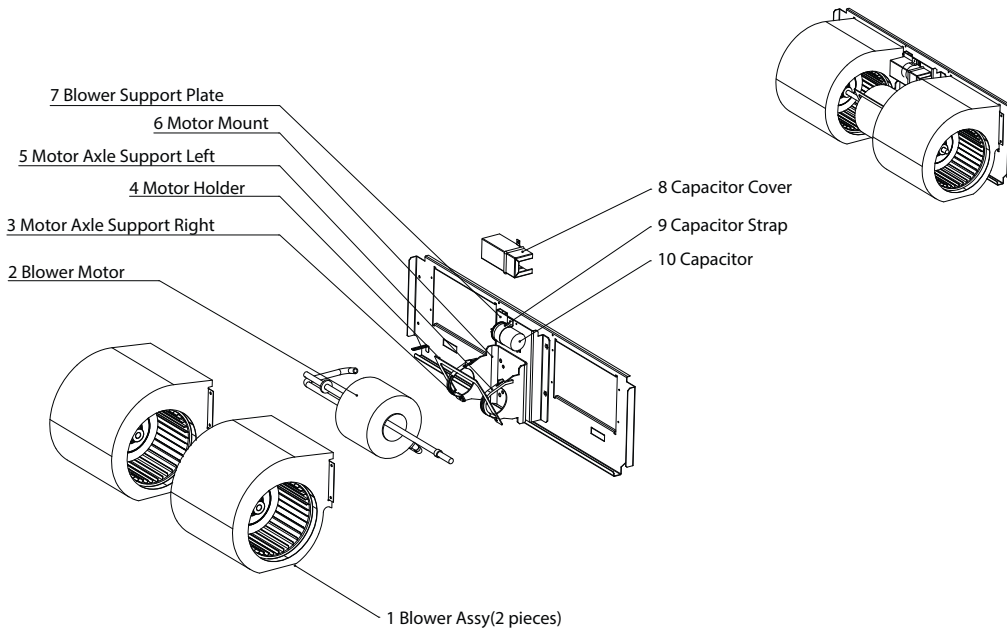

NOTE: This illustration is for reference only. Unit may differ in appearance or may not include all components shown.

Figure 2 – PSC Blower Parts

A180030

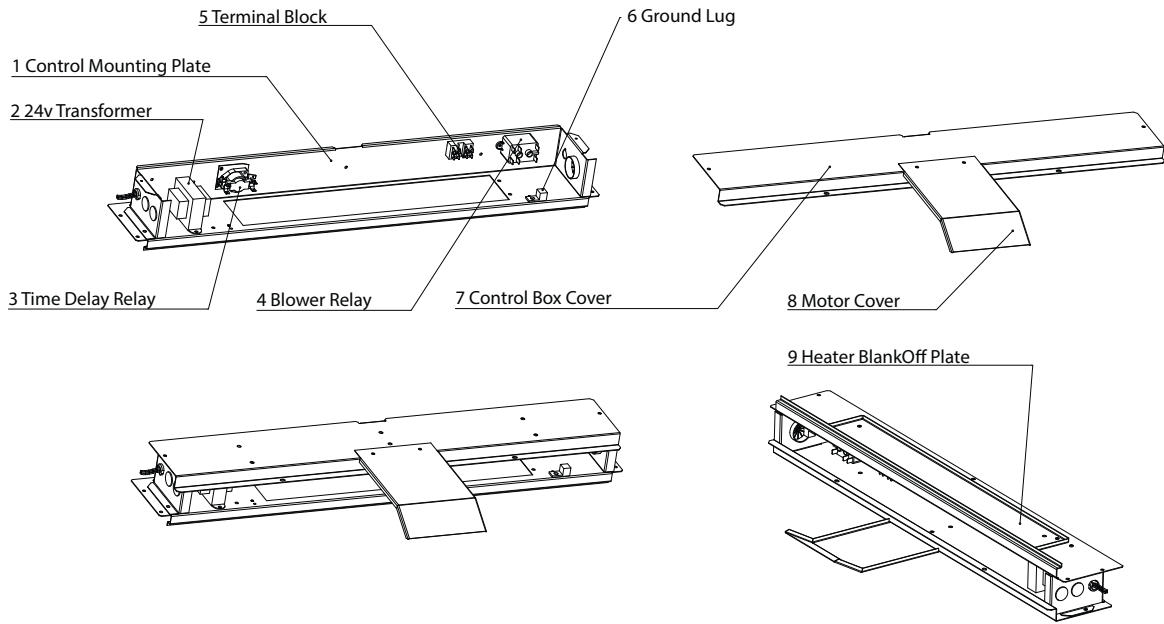

NOTE: This illustration is for reference only. Unit may differ in appearance or may not include all components shown.

Figure 3 – PSC Electrical Parts

A180027

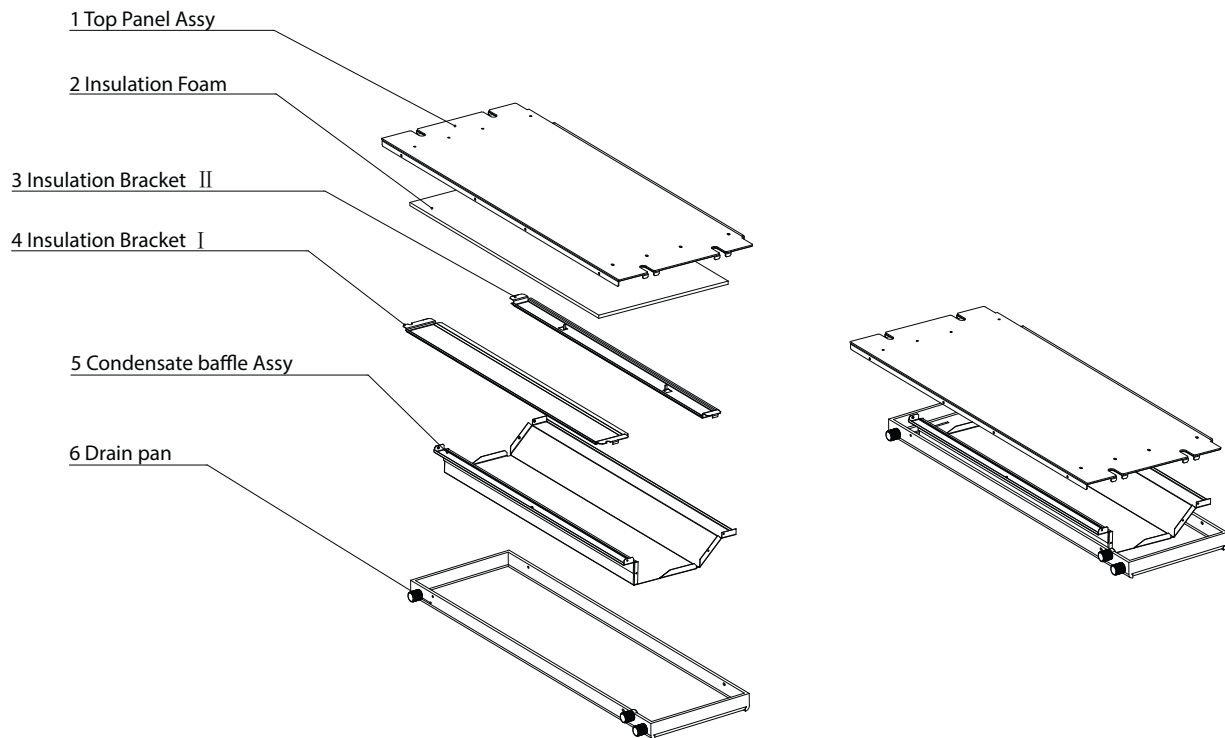

NOTE: This illustration is for reference only. Unit may differ in appearance or may not include all components shown.

Figure 4 – PSC Internal Case

A180028

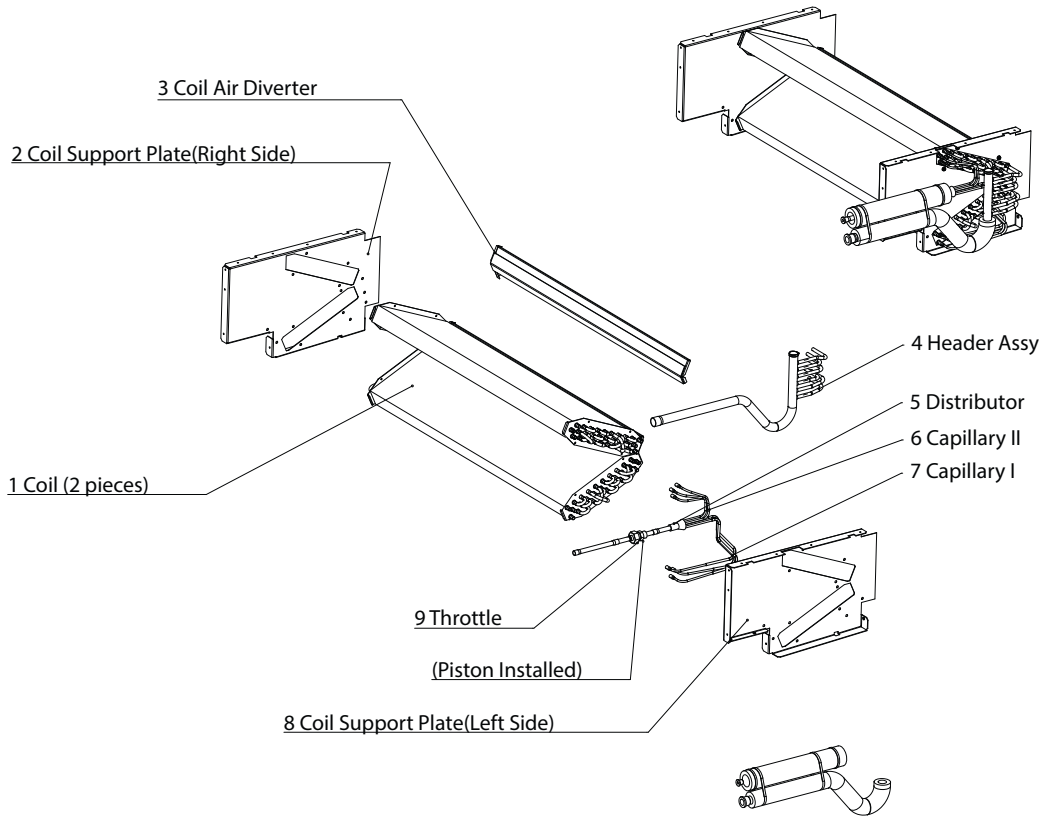

NOTE: This illustration is for reference only. Unit may differ in appearance or may not include all components shown.

Figure 5 – PSC Coil Parts

A180029

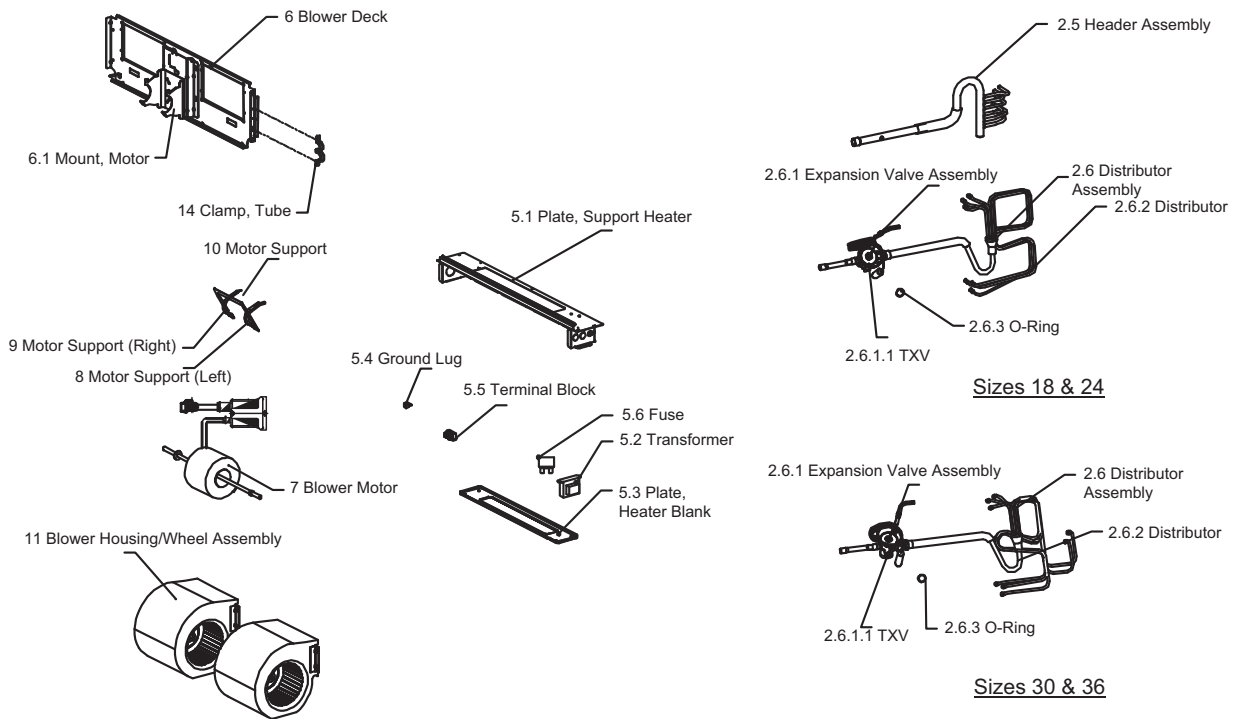

NOTE: This illustration is for reference only. Unit may differ in appearance or may not include all components shown.

Figure 6 – FMU4Z and FMC4Z Models – Blower and Coil Parts

A180051

CARE AND MAINTENANCE

The minimum maintenance requirements for this equipment are as follows:

1. Inspect and clean or replace air filter each month or as required.
2. Inspect cooling coil, drain pan, and condensate drain each cooling season for cleanliness. Clean as necessary.
3. Inspect blower motor and wheel for cleanliness each heating and cooling season. Clean as necessary.
4. Inspect electrical connections for tightness and controls for proper operation each heating and cooling season. Service as necessary.

⚠ CAUTION

CUT HAZARD

Failure to follow this caution may result in personal injury. Sheet metal parts may have sharp edges or burrs. Use care and wear appropriate protective clothing and gloves when handling parts.

A. Air Filter

The air filter should be replaced as needed.

⚠ CAUTION

UNIT DAMAGE HAZARD

Failure to follow this caution may result in equipment damage.

Never operate unit without a filter.

B. Cooling Coil, Drain Pan, and Condensate Drain

The cooling coil is easily cleaned when it is dry. Inspect coil and clean (if necessary) before each cooling season. To check or clean cooling coil, remove blower/heater access panel to gain full access to cooling coil. If coil is coated with dirt or lint, vacuum with a soft brush attachment.

Be careful not to bend coil fins. If coil is coated with oil or grease, clean it with a mild detergent and water solution. Rinse coil with clear water.

Be careful not to splash water onto insulation.

Inspect drain pan and condensate drain at same time cooling coil is checked. Clean drain pan and condensate drain by removing any foreign matter from pan. Flush pan and drain tube with clear water.

If drain tube is restricted, it can generally be cleared by high-pressure water. Cut plastic line and work outside condensate pan and away from coil to clear drain tube.

NOTE: There MUST be a trap in condensate line. Trap must be at least 3-in. deep, not higher than the bottom of unit condensate drain opening, and pitched downward to an open drain or sump.

⚠ CAUTION

UNIT DAMAGE HAZARD

Failure to follow this caution may result in equipment damage.

Do not use caustic household drain cleaners in the condensate pan or near the coil. Drain cleaners can quickly destroy a coil.

C. Disconnecting the Control Box Assembly

1. Disconnect power.

⚠ WARNING

ELECTRICAL OPERATION HAZARD

Failure to follow this warning could result in personal injury or death.

Before installation or servicing system, always turn off main power to system. There may be more than one disconnect switch. Turn off accessory heater power if applicable. Lock out and tag switch with a suitable warning label.

2. Remove control box cover (four screws).



Figure 7 – Control Box Cover Removal

A13385

3. Remove control box assembly (five screws). If there is not enough slack in field wiring (high and low voltage), it is recommended to disconnect field wiring.

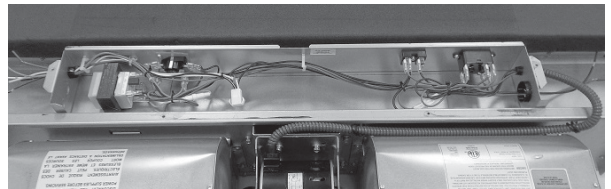

Figure 8 – Control Box Removal

A13386

D. FMC4X & FMU4X – Disconnecting the Blower Assembly

1. Disconnect power.

⚠ WARNING

ELECTRICAL OPERATION HAZARD

Failure to follow this warning could result in personal injury or death.

Before installation or servicing system, always turn off main power to system. There may be more than one disconnect switch. Turn off accessory heater power if applicable. Lock out and tag switch with a suitable warning label.

2. Remove control box cover (four screws). (See Figure 7)

3. Disconnect the (four) blower-motor power wires, noting connection locations. (See Figure 8)
4. Loosen the conduit holding ties.

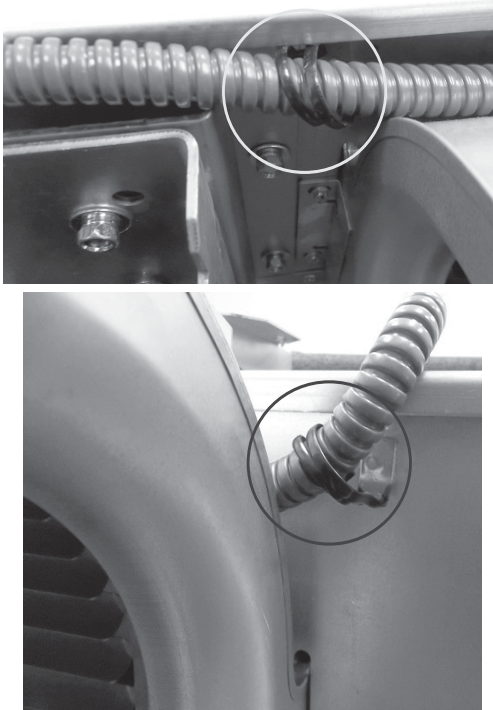

Figure 9 – Conduit Holding Ties

A13387

5. Remove the four outer screws that attach the blower support plate to each evaporator coil support.

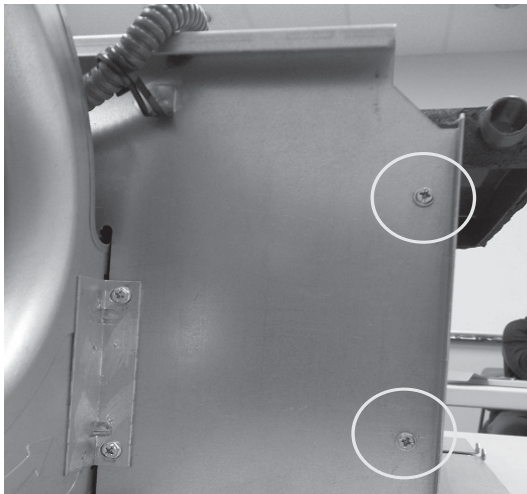

Figure 10 – Blower Support Plate Screws

A13388

6. Remove the two middle screws above/behind the blower motor that's attached to the top plate.

⚠ CAUTION

PERSONAL INJURY HAZARD

Failure to follow this caution may result in personal injury. After removing the sixth and final screw in Step 6, the blower assembly will be completely disconnected from the unit. Be ready to lower the blower assembly.

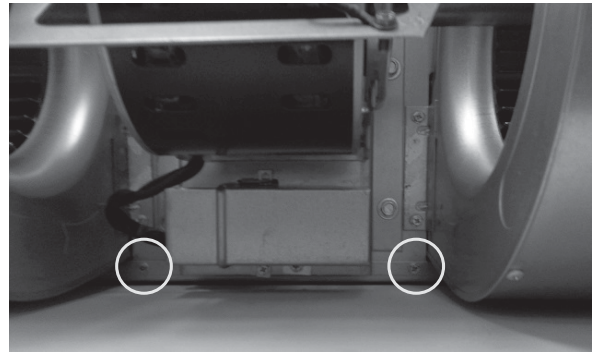

Figure 11 – Remove Middle Screws

A13389

E. FMC4X & FMU4X – Servicing the Fan Motor

1. After removing the blower housing from the unit, disconnect ground wire from screw on grounding bracket.



Figure 12 – Disconnect Ground Wire

A13390

2. Remove grounding bracket from motor-mount assembly. At this point, the clamp brackets will be loose and can be removed.

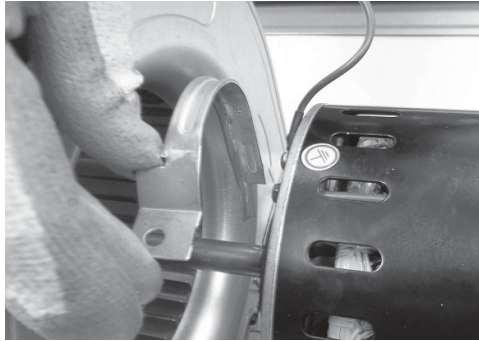
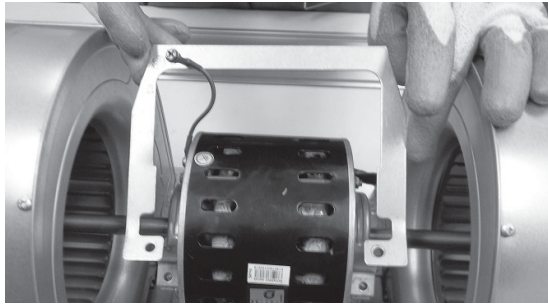

Figure 13 – Remove Grounding Bracket

A13391

3. Remove capacitor cover.

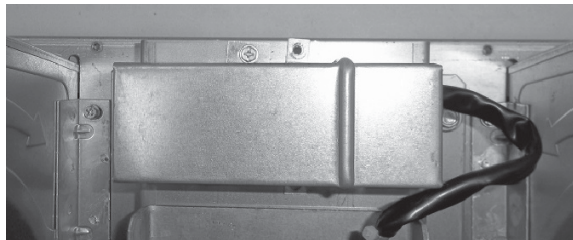

Figure 14 – Capacitor Cover

A13392

⚠ WARNING

ELECTRICAL SHOCK HAZARD

Failure to follow this warning could result in equipment damage or equipment damage.

Capacitors can store electrical energy when power is off. Electrical shock can result if you touch the capacitor terminals and discharge the stored energy. Exercise extreme caution when working near capacitors. With power off, discharge stored energy by shorting across the capacitor terminals with a 15,000-ohm, 2-watt resistor.

Always check capacitors with power off. Attempting to troubleshoot a capacitor with power on can be dangerous. Defective capacitors may explode when power is applied. Insulating fluid inside is combustible and may ignite, causing burns.

4. Disconnect capacitor leads from capacitor.

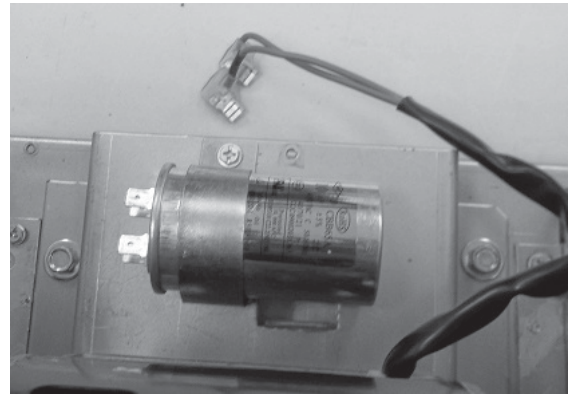

Figure 15 – Capacitor Leads

A13393

5. Loosen blower-wheel set screws from each motor shaft, accessing them through the blades of the blower wheels, with a Phillips screwdriver.

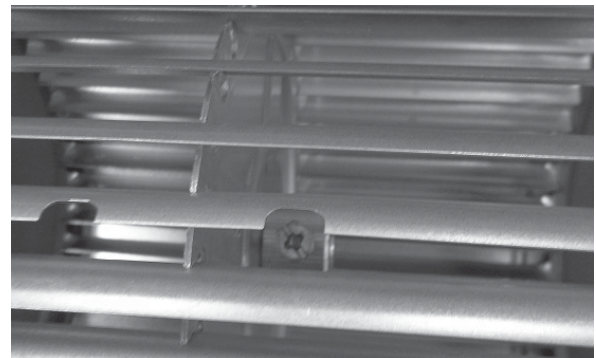

Figure 16 – Loosen Blower Set Screw

A13394

6. Disconnect one of the blower housings by removing the four housing screws.



Figure 17 – Disconnect Blower Housing

A13395

7. Remove housing from support plate and motor shaft.

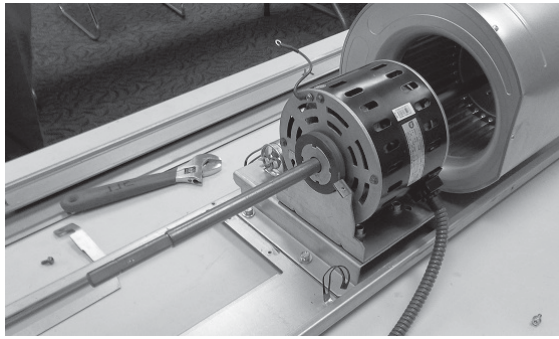

A13396

Figure 18 – Remove Blower Housing

8. Pull motor out of second housing, which can remain attached to the support plate.

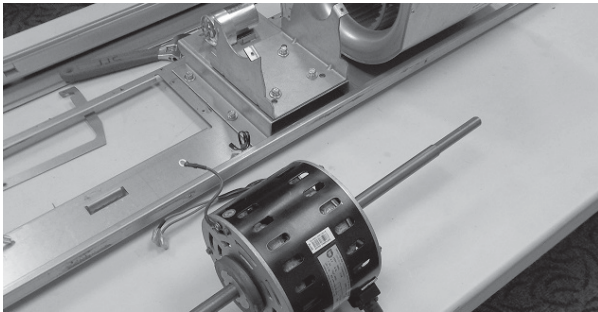

A13397

Figure 19 – Remove Motor from Second Housing

9. Reverse these steps to reinstall.

F. FMC4Z & FMU4Z – Disconnecting the Blower Assembly

1. Disconnect power.
2. Remove control box cover (four screws). (See Figure 20)

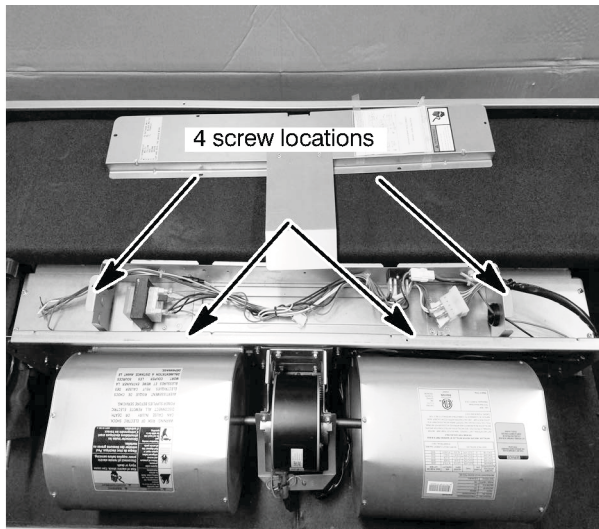

A180031

Figure 20 – Removing Control Box Cover

3. Disconnect the blower motor white power plug and green and wire speed tap wires, noting connection locations. (See Figure 21)

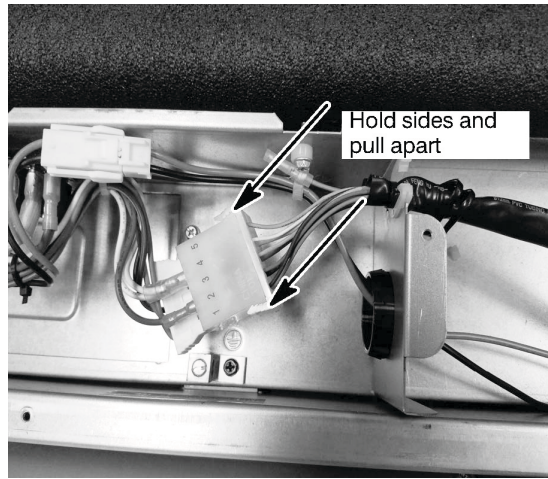

A180032

Figure 21 – Disconnect the Blower Motor

4. Loosen the conduit holding ties. (See Figure 22)

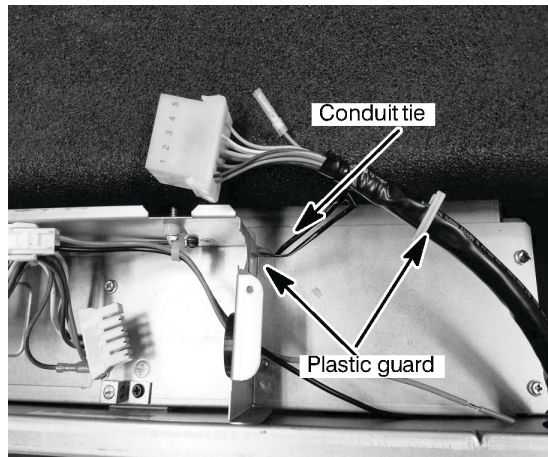

A180033

Figure 22 – Loosen the Conduit Ties

5. Remove the two middle screws above/behind the blower motor that's attached to the top plate.
6. Remove the two outer screws that attach the blower support plate to right evaporator coil support. (See Figure 23)

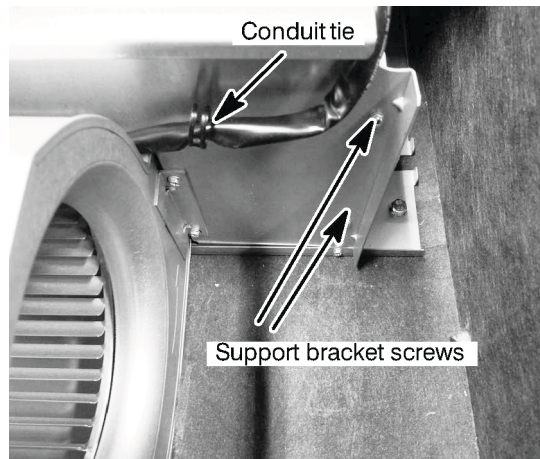

A180034

Figure 23 – Remove Outer Screws from Support Plate

- Remove the top and middle screw of the refrigerant tubing holding bracket. (See Figure 24)

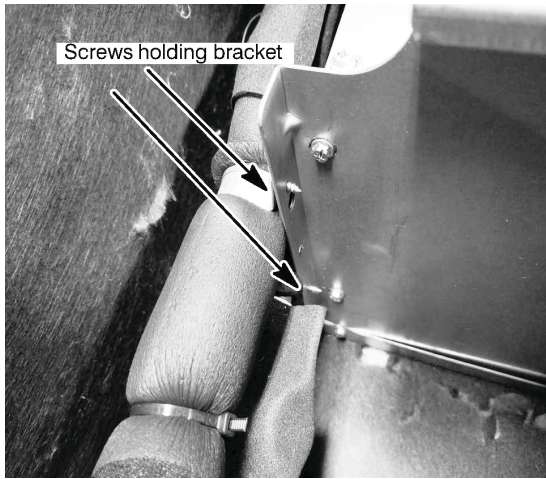

A180035

Figure 24 – Remove Top and Middle Screw

- Bend the holding bracket to release from around the tubing. (See Figure 25 & Figure 26)

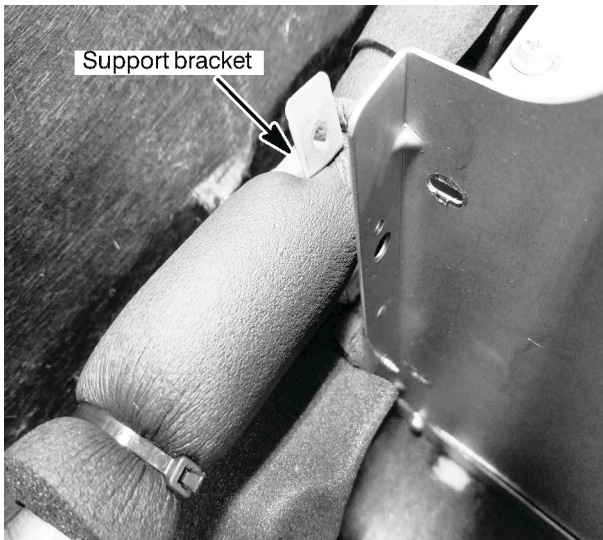

A180036

Figure 25 – Remove Two Outer Screws

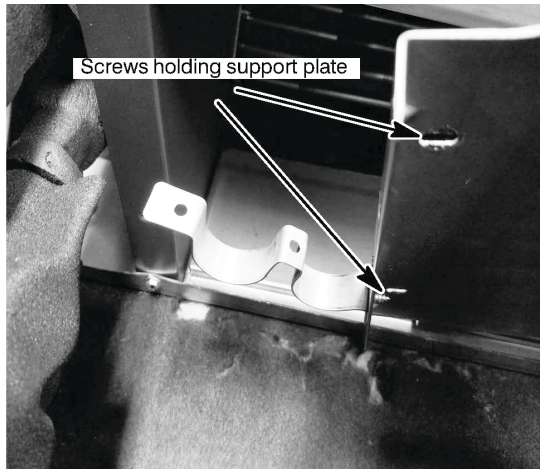

A180037

Figure 26 – Screws Holding Support Plate

- Remove the two outer screws that attach the blower support plate to left evaporator coil support. (See Figure 27) This will completely release the blower assembly from the unit.

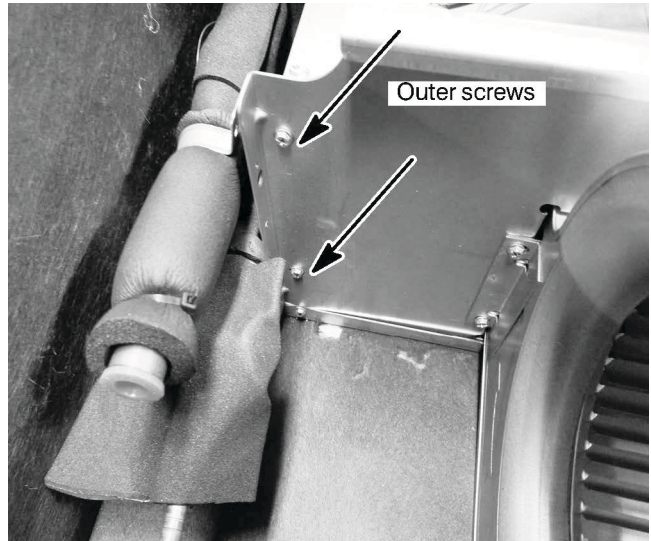

A180038

Figure 27 – Two Outer Screws

▲ CAUTION

PERSONAL INJURY HAZARD

Failure to follow this caution may result in personal injury.

After removing the final screw from Step 9., the blower assembly will be completely disconnected from the unit. Be ready to lower the blower assembly.

G. FMC4Z & FMU4Z – Servicing the Fan Motor

- After removing the blower housing from the unit, remove grounding bracket from motor-mount assembly by removing the two screws. (See Figure 28 & Figure 29)

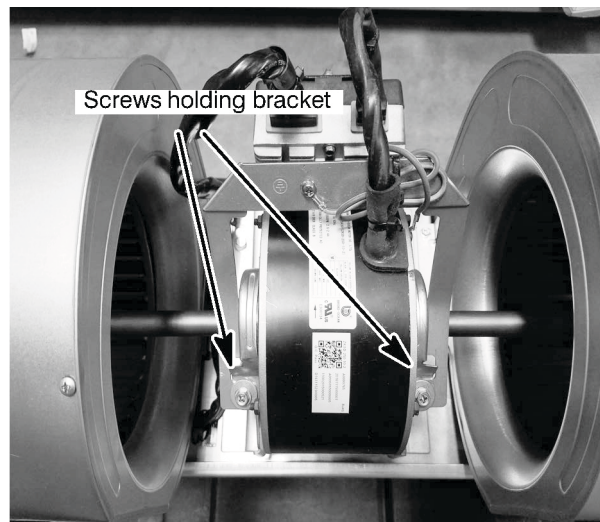

A180045

Figure 28 – Screws Holding the Bracket

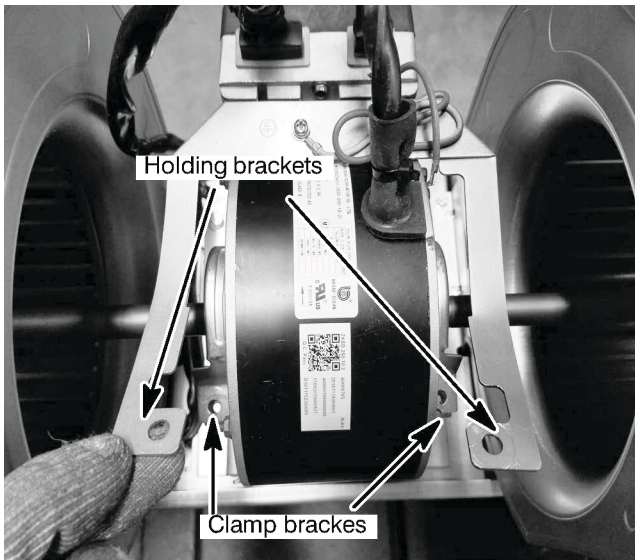

A180046

Figure 29 – Bend the Holding Bracket

2. At this point, the clamp brackets will be loose and can be removed. (See Figure 30)

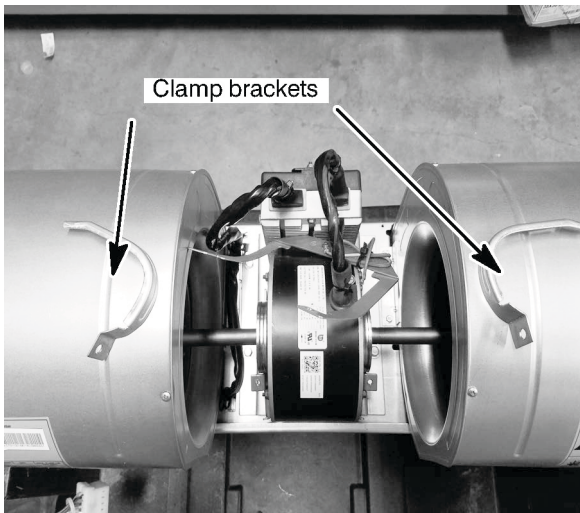

A180047

Figure 30 – Remove Clamp Brackets

3. Loosen blower-wheel set screws from each motor shaft, accessing them through the blades of the blower wheels, with a Phillips screwdriver. (See Figure 16).
4. Disconnect one of the blower housings by removing the four housing screws. (See Figure 17)
5. Remove housing from support plate and motor shaft.
6. Pull motor out of second housing, which can remain attached to the support plate.
7. The ECM module is attached below the motor with two Philips head screws to a bracket. (See Figure 31 & Figure 32)

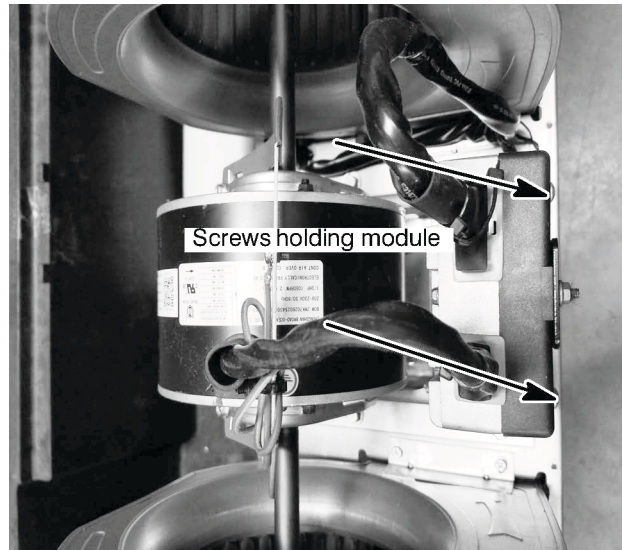

A180048

Figure 31 – Remove Module

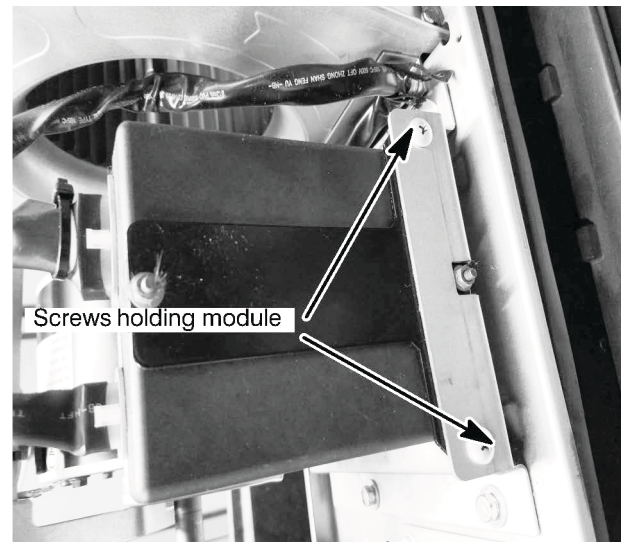

A180049

Figure 32 – Remove Module

8. Reverse these steps to reinstall.

H. Cleaning the A-Coil

The A-coil can be accessed for cleaning by removing either the control box assembly or the blower assembly. (Refer to those previous instructions)

I. Removing the Drain Pan

1. Disconnect condensate drains, if necessary.
2. Remove the four screws located near the corners. (See Figure 33)
3. Lower drain pan from unit.

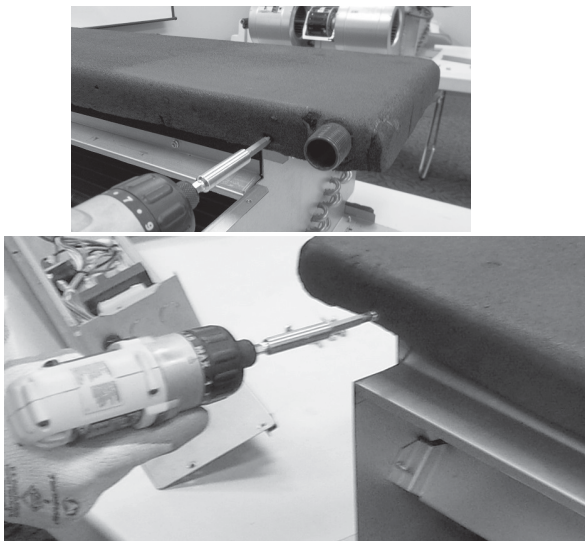

A13398

Figure 33 – Removing Condensate Pan

J. Changing the A-Coil

1. Disconnect power.
2. Disconnect field wiring (low and high voltage).
3. Disconnect condensate drain.
4. Remove entire fan coil unit from installation location.
5. Remove control box assembly. (See previous instructions)
6. Remove blower assembly (See previous instructions)
7. Remove drain pan (see previous) to the top plate.
8. From top of unit, remove the ten screws holding the coil assembly to the top plate.

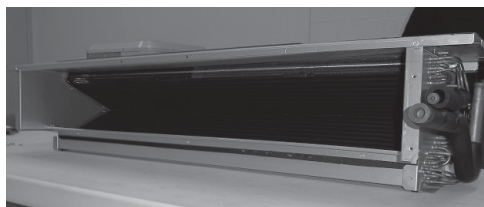
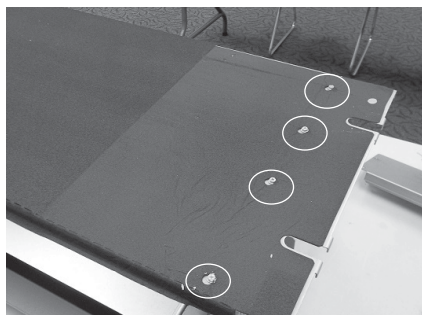

A13399

Figure 34 – Remove Top-Plate Screws

9. Remove the top plate and insulation.

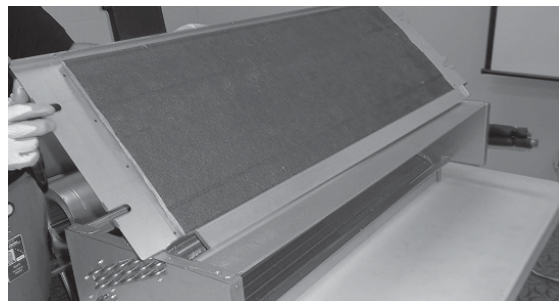

A13400

Figure 35 – Top Plate and Insulation

10. Remove the two insulation support brackets.

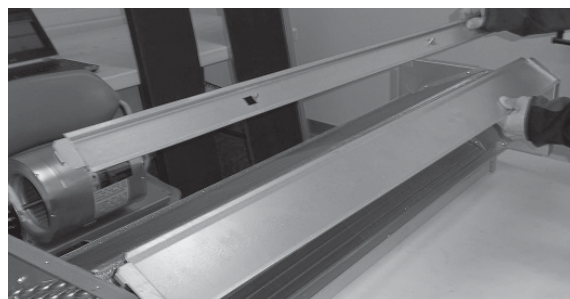

A13401

Figure 36 – Insulation Support Brackets

11. On bottom of unit, remove the eight screws attaching the condensate baffle assembly to the side coil supports.

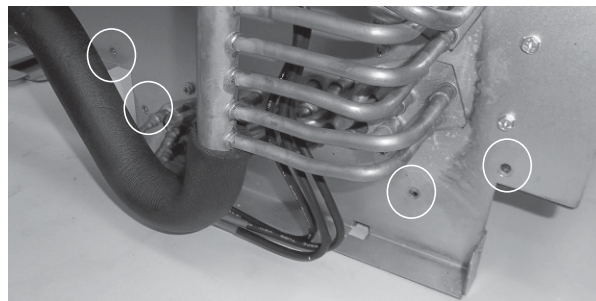

A13402

Figure 37 – Condensate Baffle Screws

12. Remove condensate baffle assembly.

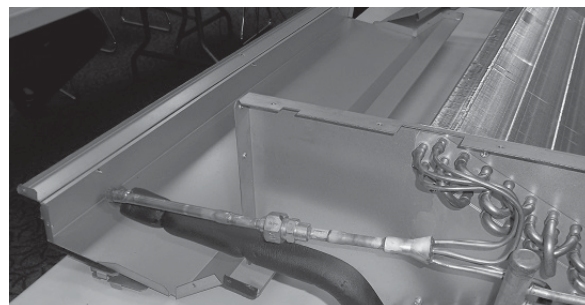

A13403

Figure 38 – Remove Condensate Baffle Assembly

K. Refrigerant Metering Device

The refrigerant metering device is located on the side of the fan coil unit, in-line with the liquid refrigerant line . FMC4X, FMU4X, FMC4Z, FMU4Z Fan Coils are shipped with an R-410A TXV metering device. Use two wrenches to remove the TXV.