

Installation Instructions

PHF3 Series 3 Phase

PACKAGE HEAT PUMPS



TABLE OF CONTENTS

UNIT DIMENSIONS	2	ELECTRICAL WIRING	4
SAFE INSTALLATION REQUIREMENTS	3	DUCTWORK	6
LOCATING THE UNIT	3	FILTERS	6
CLEARANCES	3	AIRFLOW ADJUSTMENT	7
INSTALLATION	3	START-UP PROCEDURES	7
GROUND LEVEL INSTALLATION	3	SEQUENCE OF OPERATION	8
ROOFTOP INSTALLATION	3	MAINTENANCE	9
HOISTING	4	RIGGING	11
DOWNFLOW CONVERSION	4	WIRING DIAGRAMS	12 - 15
CONDENSATE DRAIN	4		



1. UNIT DIMENSIONS

3 TO 4 TON

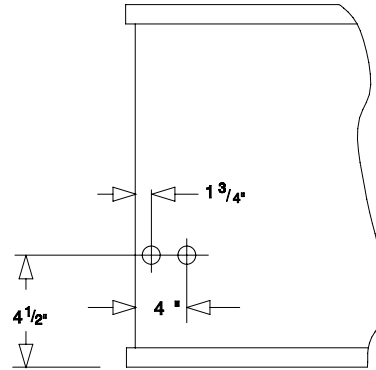
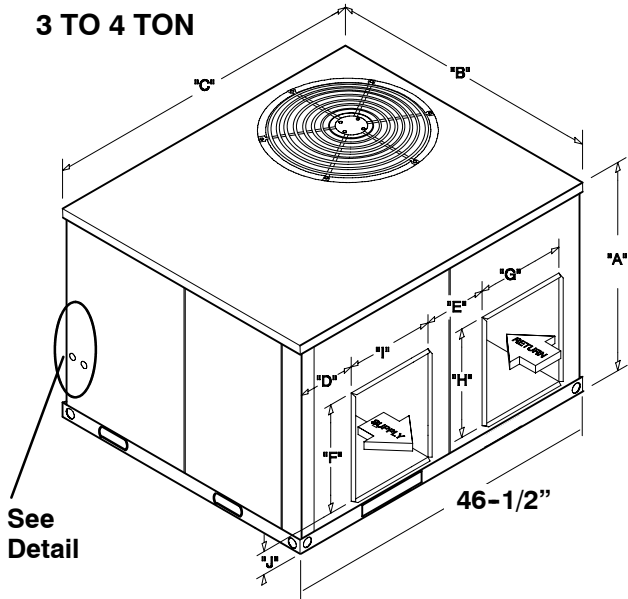

BASE PAN - CHASSIS

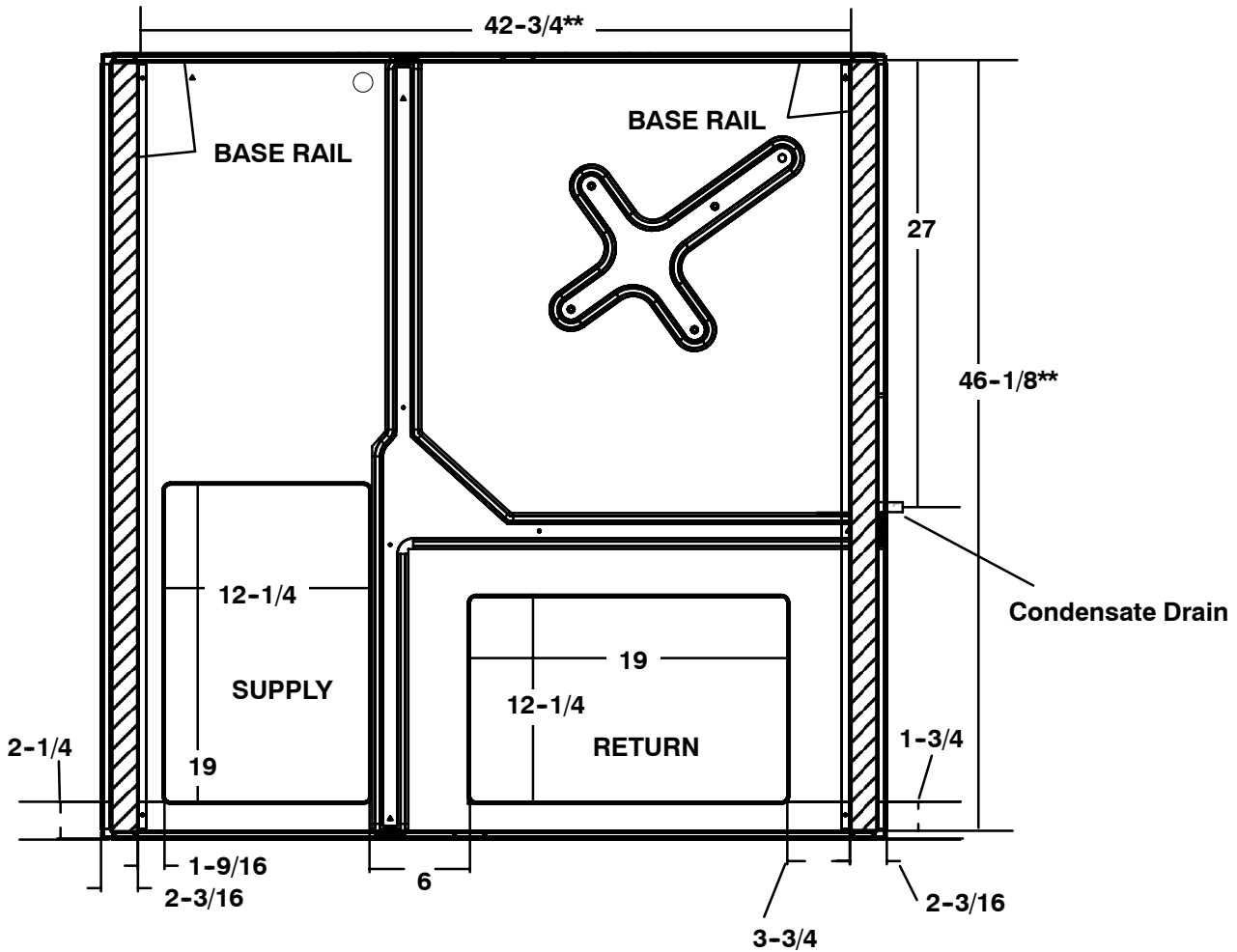

UNIT SIZE	A	B	C	D	E	F	G	H	I	J
3 to 4 Ton	37-1/2	47-1/2	47-1/2	4	6-1/2	19	19	12	12	4-1/2

** Measured from inside to inside on base rails.

2. SAFE INSTALLATION REQUIREMENTS

⚠ WARNING
FIRE AND ELECTRICAL SHOCK HAZARD

Failure to carefully read and follow all instructions in this manual could result in furnace malfunction, personal injury, death and/or property damage.

Installation or repairs made by unqualified persons can result in hazards to you and others. Installation **MUST** conform with local building codes or, in the absence of local codes, with the National Electrical Code NFPA70-2005 or in Canada and CSA C.22.1 - Canadian Electrical Code Part 1.

The information contained in this manual is intended for use by a qualified service technician familiar with safety procedures and equipped with the proper tools and test instruments.

- Seal supply and return air ducts.
- Check to see that filters are installed correctly and are the proper type and size.

NOTE: It is the personal responsibility and obligation of the customer to contact a qualified installer to ensure that the installation is adequate and conforms to governing codes and ordinances.

3. LOCATING THE UNIT

ACCESS PANELS

See Figure 1 for a general view of unit and location of access panels.

CLEARANCES

The location **MUST** allow for minimum clearances and should not be adjacent to a patio or other area where the unit's operating sound level might be objectionable.

NOTE: Units with available filter racks, need a 26" minimum clearance at side of unit for removal of filters. See chart below if unit is going to be placed near combustible construction or materials.

While minimum clearances are acceptable for safety reasons, they may not allow adequate air circulation around the unit for proper operation in the cooling mode. Whenever possible, it is desirable to allow additional clearance, especially around the condenser inlet and discharge openings.

Do **NOT** install the unit in a location that will permit discharged air from the condenser to recirculate to the condenser inlet.

⚠ CAUTION
UNIT DAMAGE HAZARD

Failure to follow this caution may result in shorten life of unit components.

Do **NOT** operate unit in a corrosive atmosphere containing chlorine, fluorine, or any other corrosive chemicals.

Minimum Clearances to Combustible Construction

Duct Side	2" (6" on large chassis models)
Condenser Inlet	30"
Blower Service (Side)	30"
Control Service Side	
(Front Combustion Air Inlet)	30"
Clearance between 3 Ft. Overhang and Top of Unit	30"
Combustible Base	
(Wood or Class A, B or C roof covering material)	0"

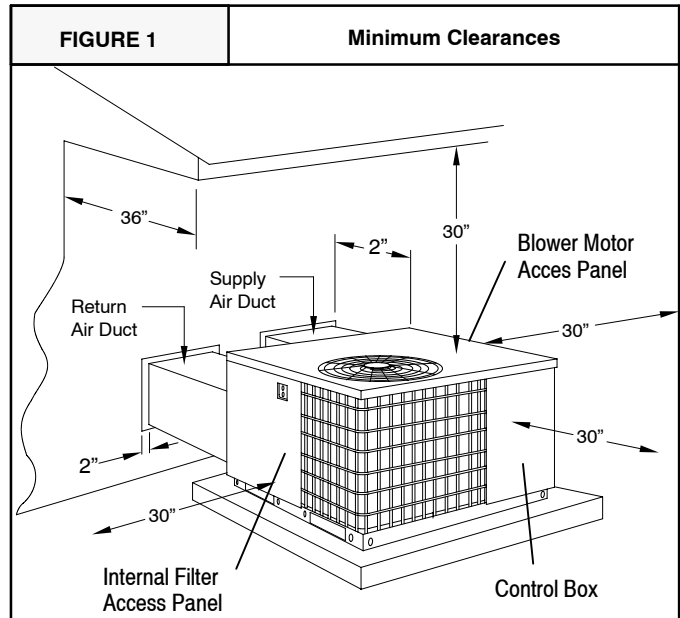

INSTALLATION

NOTICE

Unit will NOT operate properly unless it is installed level front to rear and side to side. The slope MUST NOT be greater than 1/8" per foot (10mm per meter). For side to side leveling, the drain side MUST always be lower.

Ground Level Installation

Ground level platform requirements:

- The unit **MUST** be situated to provide safe access for servicing.
- The unit must be level and supported above grade by beams, platform, or a pad. Platform or pad can be of open or solid construction but should be of permanent materials such as concrete, bricks, blocks, steel, or pressure-treated timbers approved for ground contact. Soil conditions must be considered so that the platform or pad does not shift or settle and leave the unit partially supported.
- Position platform separate from building foundation.
- Install in well-drained area, with top surface of platform above grade level.
- Platform must be high enough to allow for proper condensate trap installation and drainage. See **FIGURE 2** and associated text for more information about condensate drainage.

Rooftop Installation

Rooftop platform requirements:

- The unit **MUST** be situated to provide safe access for servicing.
- The existing roof structure **MUST** be adequate to support the weight of the unit or the roof **MUST** be reinforced.
Check the weight of the unit in relation to the roof structure and local building codes or ordinances and reinforce roof structure if necessary. See page 11 of this manual for unit weights.
- Support for the unit **MUST** be level and strong enough to carry unit weight. The support may consist of a platform or a combination of platform and roof beams or curb.
- See *Hoisting* section for hoisting instructions.

HOISTING

NOTE: All access panels **MUST** be secured in place before hoisting.

The unit should be hoisted with two lifting slings. Attach the slings to rigging shackles that have been hooked through holes in the base rail.

Two spreader bars **MUST** be placed on top of the unit to protect the unit from damage from the pressure exerted by the slings. Make sure that all equipment is adequate to handle the weight of the unit and that the slings will not allow the unit to shift.

Refer to **FIGURE 9** on page 11 of this manual for illustrated rigging instructions and weight chart.

DOWNFLOW CONVERSION

NOTE: In downflow applications with roof curbs or jack stands, the center rail under the unit must be removed. The center rail is attached to the base rail with screws.

These units are adaptable to downflow use. To convert to downflow use, follow these steps:

1. Remove the blockoff plates found in the return air compartment and the supply air compartment.

NOTE: Blockoff plate in the supply air compartment only contains one screw. If reinstalling plate, back part of plate **MUST** fit into mating dimples on flange. To reinstall, slant plate into dimples, then put plate into position and fasten with screw.

2. Install the removed plates on the horizontal return and supply air openings.
3. Install roof curb on the building. Be sure to follow all directions included with curb and all applicable building codes in your installation.

Condensate Drain

The condensate drain outlet is a $\frac{3}{4}$ " (19.1mm) female PVC connection located at the bottom on the left hand side (see **FIGURE 2**).

The circulating blower creates a negative pressure on the condensate drain line that can prevent the condensate from draining properly. To combat this negative pressure, a field supplied condensate trap that will allow a standing column of water of at least 2" (50.8mm) **MUST** be installed. Top of outlet from trap **MUST** be at least 1" (25.4mm) below top of

outlet from unit. **Install the trap as near to the unit as possible for proper drainage.**

A $\frac{3}{4}$ " (19.1mm) drain line **MUST** be installed if required by local codes or if location of unit requires it. Run the drain line to an open drain or other suitable disposal point.

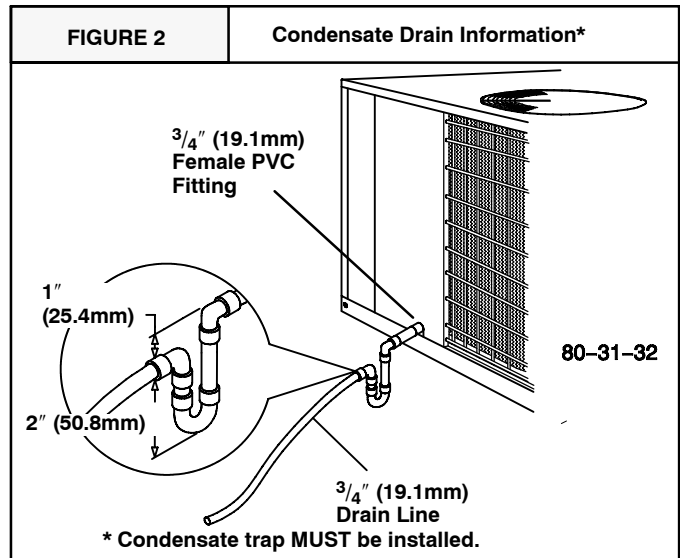

4. ELECTRICAL WIRING

⚠ WARNING

ELECTRICAL SHOCK HAZARD.

Failure to follow this warning could result in personal injury, death and/or property damage.

The unit cabinet must have an uninterrupted, unbroken electrical ground to minimize the possibility of serious injury if an electrical fault should occur. This ground may consist of an electrical wire connected to the unit ground lug in the control compartment, or conduit approved for electrical ground when installed in accordance with National Electric Code (NEC) NFPA 70, National Fuel Gas Code NFPA 54-2005/ANSI Z223.1-2005 and local electrical codes. In Canada, follow Canadian Electrical Code CSA (Canadian Standards Association) C22.1 and local electrical codes.



CAUTION

REDUCED EQUIPMENT LIFE HAZARD

Failure to follow these precautions could result in damage to the unit being installed.

1) Make all electrical connections in accordance with National Electric code (NEC) NFPa 70 and local electrical codes governing such wiring. In Canada, all electrical connections must be in accordance with CSA standard C22.1, Canadian Electrical Code Part 1, and applicable local codes. Refer to unit wiring diagram.

2) Use only copper conductor for connections between field-supplied electrical disconnect switch and unit. DO NOT USE ALUMINUM WIRE.

3) Be sure that high-voltage power to unit is within operating voltage range indicated on unit rating plate.

4) Do not damage internal components when drilling through any panel to mount electrical hardware, conduit, etc. Consult local power company for correction of improper voltage and/or phase imbalance.

Disconnect Switch

The unit must have separate electrical service with a field-supplied, waterproof, disconnect switch mounted at, or within sight from, the unit. Refer to the unit rating plate for maximum fuse/circuit breaker size and minimum circuit amps (ampacity) for wire sizing.

Ground Connections

Do **NOT** complete line voltage connections until unit is permanently grounded. All line voltage connections and the ground connection **MUST** be made with copper wire.

A ground lug is installed in the control box area for the ground connection. Use a copper conductor of the appropriate size from the unit to a grounded connection in the electrical service panel or a properly driven and electrically grounded ground rod. See warning above.

Line Voltage Wiring - (Wiring Diagrams page 12 & 13)

Connections for line voltage are made in the unit control box area. Refer to wiring diagram located on the Access panel. For access, remove the burner access panel.

1. Run the high voltage (L1, L2 and L3) wires and ground leads into the control box.
2. Connect ground lead to chassis ground connection.
3. Connect L1 to pressure lug connection 11 of the compressor contactor.
4. Connect L2 to pressure lug connection 13 of the compressor contactor.
5. Connect L3 to the bare Blue wire from the compressor power plug, using a wire nut and insulate it with electric tape.

Converting 230V Units to 208V

To convert 230V units to 208V:

1. Turn electric power **OFF**.
2. Remove the electrical access panel.
3. Locate the 24V control transformer.
4. Remove wires from the terminal labeled "240V" on the 24V control transformer and reconnect them to the 208V terminal of the 24V control transformer.

5. Replace the electrical access panel.

Accessory Economizer Wiring

This unit has factory-routed wiring required for using an accessory economizer. (Refer to product specification sheets for an accessory economizer that is compatible with this unit.)

The factory-routed economizer wiring consists of:

There are 8 wires in the low voltage connection area. These wires must be stripped and connected to thermostat and/or unit pigtail connections per the economizer accessory installation instructions.

There are two gray wires with 1/4" quick connects wire-tied to the indoor blower motor harness above the blower housing. These two gray wires must be connected to the mixed-air sensor shipped with the accessory economizer. The mixed air sensor must be mounted per the economizer accessory installation instructions.

There is a 12 pin plug connection above the return opening. The economizer accessory comes with two wire harnesses connected with a 12 pin plug. Unplug these two harnesses and connect the one to the 12 pin plug connection found above the return opening. Discard the unused harness. Refer to the economizer accessory installation instructions for proper installation.

Thermostat / Low Voltage Wiring

Location of the thermostat has an important effect on home comfort. FOLLOW THE THERMOSTAT INSTRUCTION MANUAL FOR CORRECT LOCATION, MOUNTING, AND WIRING.

For 3 to 3-1/2 Ton Models Only:

A single stage thermostat is required for proper operation. Thermostat must have the following terminals: "R", "W", "O", and "G". Some electronic thermostats use low voltage from the unit for power for temperature display and programming. These electronic thermostats will have a "C" terminal. The outdoor unit has color-coded wires for easy connection. Using wire nuts, follow **Figure 3** for proper connections:

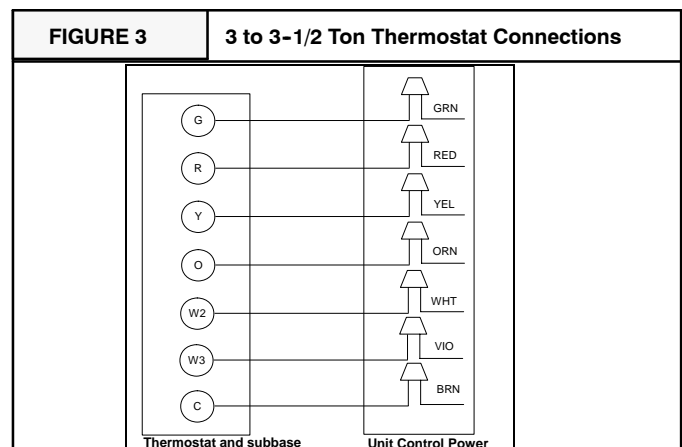

For 4 Ton Models Only:

A two-stage thermostat is required for proper operation. Thermostat should have the following terminals: "R", "W/W1", "Y1", "O", and "G". Some electronic thermostats use low voltage from the unit for power for temperature

display and programming. These electronic thermostats will have a "C" terminal. The outdoor unit has color-coded wires for easy connection. Using wire nuts, follow **Figure 4** for proper connections:

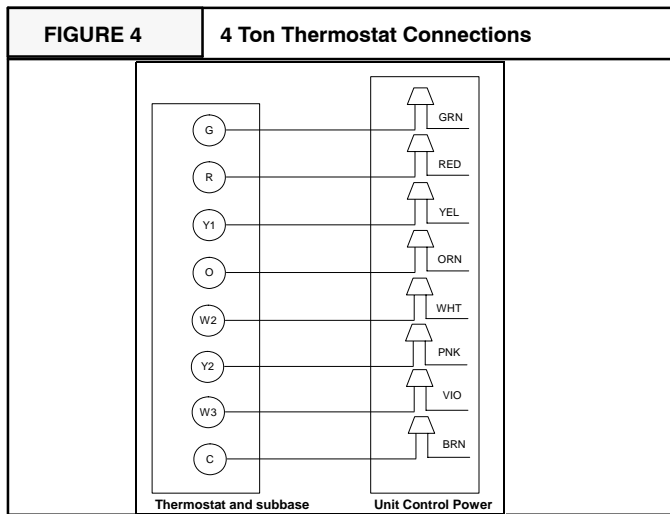

THERMOSTAT HEAT ANTICIPATOR

Some thermostats have an adjustable heat anticipator. The heat anticipator prevents temperature overshoot in heating mode. If the heat doesn't turn off until the set point temperature on the thermostat is exceeded, then the anticipator setting is too low. If the heat turns off before the thermostat reaches the set point temperature on the thermostat, then the anticipator setting is too high. Follow the thermostat instruction manual for proper adjustment of the heat anticipator.

Final Electrical Check

1. Make a final wiring check to be sure system is correctly wired. Inspect field installed wiring and the routing to ensure that rubbing or chafing due to vibration will not occur.

NOTE: Wiring **MUST** be installed so it is protected from possible mechanical damage.

5. DUCTWORK

Ductwork Sizing

The maximum recommended velocity in trunk ducts is 1000 feet per minute. The maximum recommended velocity in branch ducts is 800 feet per minute.

Ductwork sizing affects the discharge temperature, airflow velocity, and efficiency of the system. Be sure to properly size ductwork to the capacity of the unit and to the airflow requirements of the conditioned space. Failure to properly size ductwork can result in inadequate airflow and poor efficiency. Undersized ductwork may result in tripped limit controls and premature failure of compressors, motors and other components.

Ductwork Insulation

Ductwork installed outdoors must have a minimum 2" thick fiberglass "wrap" insulation and a weatherproof vapor barrier installed around it. The insulation and vapor barrier must be protected against potential damage. Caulking, flashing, and other means of providing a permanent weather seal must be used.

Ductwork Connections

The use of flexible, non-combustible connectors between main trunk ducts and supply and return air plenums is permitted. If flexible connectors are used, they should be protected from potential mechanical damage such as punctures and tears.

NOTE: When connecting the supply and return plenums to the unit, make sure that the plenums are sealed against the side casing of the unit and do not interfere with removal of the top of the unit.

FILTERS

All return air **MUST** pass through a filter before entering the unit. An electronic air cleaner, optional filter racks, or other accessible filter arrangement must be installed in the return air ductwork. Minimum recommended filter sizes are listed in **Figure 5** and are based on maximum face velocities of 300 ft/min for disposable filters and 500 ft/min for washable (high velocity) filters. See figure 5 for filter sizes.

⚠ CAUTION

REDUCED EQUIPMENT LIFE HAZARD

Failure to follow this caution may result in improper unit operation.

Do not operate the unit without a filter.

FIGURE 5		Filter Sizes		
PHF3 Filter sizes				
Model	Disposable Filters		Washable Filters	
	Nominal Size (Qty x w x d)	Minimum Area (sq inches)	Nominal Size (Qty x w x d)	Minimum Area (sq inches)
PHF336	2 x 15" x 20"	576	1 x 18" x 20"	346
PHF342	2 x 18" x 20"	672	1 x 20" x 20"	404
PHF348	2 x 20" x 20"	768	1 x 20" x 24"	461

6. AIRFLOW ADJUSTMENT

NOTE: Indoor blower motor is 230v single phase, see wiring diagram for details.

CIRCULATING AIR BLOWER SPEEDS

BLOWER PERFORMANCE DATA													
Model Number	PHF336				PHF342				PHF348				
Speed Tap	1	2	3	4	1	2	3	4	1	2	3	4	
Air Delivery in CFM @ Varying External Static Pressure (in. w.c.)	0.1	1162	1278	1529	1652	1138	1240	1505	1643	1154	1245	1750	1908
	0.2	1118	1233	1484	1607	1087	1189	1467	1609	1084	1170	1696	1864
	0.3	1062	1191	1440	1574	1041	1145	1431	1577	1005	1110	1643	1819
	0.4	1014	1149	1402	1541	989	1104	1398	1541	940	1034	1592	1770
	0.5	958	1108	1364	1501	940	1063	1363	1509	880	972	1547	1720
	0.6	892	1060	1326	1462	865	1010	1324	1476	832	924	1497	1678
	0.7	826	1005	1284	1426	806	952	1283	1439	780	875	1443	1632
	0.8	780	943	1238	1384	752	891	1234	1402	713	836	1400	1586
	0.9	735	892	1179	1338	694	828	1175	1352	663	773	1354	1538
	1	675	844	1123	1277	646	773	1120	1264	613	720	1302	1494

Notes: Air Delivery @ listed external static pressure are taken at 230Volts with Dry coil, no filter and approved heater.

For wet coil add .05 in. w.c. to Static Pressure measurement. Note for 208 Volts applications, reduce airflow by 15%.

FIGURE 6		Blower Tap Connections	
Model	Blower Speed Tap Settings		
	Rated Airflow	High Airflow	
PHF336	Speed Tap 2	Speed Tap 3	
PHF342	Speed Tap 3	Speed Tap 4	
PHF348	Speed Tap 3 (Hi); 2 (Lo)	Speed Tap 4 (Hi); 3 (Lo)	



Verify that the proper blower speeds for heating and cooling are selected on the blower motor by removing the blower access panel and inspecting the blower motor. The motor has 4 speeds numbered "1", "2", "3", and "4". The wires for the speed selection are as follows:

- Red** ➔ **Heating**
- Black** ➔ **High Stage Cooling**
- Violet** ➔ **Low Stage Cooling (4 ton only)**

Using the same speed for Heating and Cooling.

If the same speed is required for heating and high stage cooling the following procedure must be used:

1. Set Red wire on proper speed selection on blower motor.
2. Remove Black wire from "COOL" (3 - 3.5 Ton models) or "HI" (4 Ton Model) on Blower Interface Board. Tape end of Black lead using electrical tape.
3. Jumper the Red wire to both the "Heat" terminal and either the "COOL" (3 - 3.5 Ton models) or "HI" (4 Ton Models) terminal on the Blower Interface Board.

If the same speed is required for heating and low stage cooling (4 Ton model only), the following procedure must be used:

1. Set Red wire on proper speed selection on blower motor.
2. Remove Violet wire from "LO" on Blower Interface Board. Tape end of Violet lead using electrical tape.
3. Jumper the Red wire to both the "Heat" terminal and the "LO" terminal on the Blower Interface Board.

8. START-UP PROCEDURES

CHECK BEFORE STARTING

1. Check that the blower motor speed terminal block is running the correct heating and cooling speeds.
2. Check to see that clean, properly sized air filters are installed.
3. Replace all service access panels.

Check the unit's operation as outlined in the following instructions. If any unusual sparking, odors or unusual noises are encountered, shut off electric power immediately. Recheck for wiring errors, or obstructions in or near blower motors.

1. Set thermostat Heat-Cool selector to **OFF**.
2. Set thermostat fan switch to **AUTO**.
3. Turn electric power **ON**. Nothing should start running.
4. Set thermostat fan switch to **ON**.
5. Reset thermostat fan switch to **AUTO**.

9. SEQUENCE OF OPERATION

⚠ WARNING

ELECTRICAL SHOCK HAZARD.

Failure to follow this warning could result in personal injury, death and/or property damage.

Turn off electric power supply at disconnect switch or service panel before removing any access or service panel from unit.

Cooling Operation (PHF336 -42)

With a call for cooling (Y), the indoor fan energizes immediately where as the contactor energizes after a 5 minute time delay (incase of an initial start up) starting the compressor and the outdoor fan motor. When the cooling demand is met, (Y) de-energizes, shutting the compressor, indoor fan and the outdoor fan.

Cooling Operation (PHF348)

These units utilize a 2 stage indoor thermostat. With a first stage call for cooling (Y1), the indoor fan (low stage) energizes immediately where as the contactor energizes after a 5 minute time delay (incase of an initial start up) starting the compressor (low stage) and the outdoor fan motor. If the low stage operation cannot satisfy the cooling demand, the second stage cooling (Y2) energizes switching the compressor into high stage cooling through energizing an internal solenoid valve inside the scroll compressor and switching the indoor fan into high stage. When second stage cooling is satisfied, Y2 de-energizes switching the compressor and the indoor fan into low stage cooling. When the low stage cooling demand is met, Y1 de-energizes shutting the compressor, indoor fan and the outdoor fan.

Heating Operation (PHF336 -42)

With a call for heating (Y), the indoor fan (low stage) energizes immediately where as the contactor energizes after a 5 minute time delay (in case of an initial start up) starting the compressor and on 230v models the outdoor fan motor. On 460v models the outdoor fan motor is energized via the outdoor fan relay that is controlled by the defrost board. If (Y) cannot satisfy the heating demand, the auxiliary or back up heat (W2) energizes. Incase of staged heating, W3 is energized if the demand is not met. The highest airflow selected is run while the electric heat is in operation. When heating demand is met, W3, W2 and Y sequentially de-energize shutting the compressor, indoor fan and the outdoor fan.

Heating Operation (PHF348)

With a first stage call for heating (Y1), the indoor fan (low stage) energizes immediately whereas the contactor energizes after a 5 minute time delay (incase of an initial start up) starting the compressor (low stage) and on 230v models the outdoor fan motor. On 460v models the outdoor fan motor is energized via the outdoor fan relay that is controlled by the defrost board. If the low stage operation cannot satisfy the heating demand, the second stage heating (Y2) energizes switching the compressor into high stage heating through energizing an internal solenoid valve inside the scroll compressor and switching the indoor fan into high stage. The auxiliary or back up heat is controlled by

a third stage (W2). If the demand is not met, W3 is energized incase of staged heating. When heating demand is satisfied, W3, W2 and Y2 sequentially de-energize switching the compressor and the indoor fan into low stage heating. When the low stage heating demand is met, Y1 de-energizes shutting the compressor, indoor fan and the outdoor fan.

Scroll Recycle Delay timer

The defrost board is equipped with a recycle delay timer which will delay the start of the compressor for 5 minutes in the event of a power interruption. This sequences power throughout the system and prevents possible reverse rotation of the scroll compressor. The output of the timer controls the compressor contactor via a normally open contact of K3 (T2). The timer starts the delay cycle when the compressor is turned off by removal of "Y." If application of "Y" occurs before the timer has expired, the compressor contactor will not be energized until the timer has expired.

CONTINUOUS FAN OPERATION

With the continuous Indoor fan option selected on the thermostat, G is continuously energized. Incase of 036 - 042 units, the selected airflow setting is provided. In case of 048 units, the system runs low stage (Y1) airflow for continuous fan operation.

Defrost Mode

On a call for defrost:

When the defrost sensor closes in the heating mode, there is a 30, 60, 90 or 120 minute delay before the defrost mode begins. This delay is selected by the position of the dipswitches on the defrost board. Defrost interval timing can be configured by selection switch 1 and 2 on the dipswitch per the following table: See Figure 7.

Switch 1	Switch 2	Time
ON	OFF	30 Minutes
OFF	ON	60 Minutes
OFF	OFF	90 Minutes
ON	ON	120 Minutes

NOTES:

1. The backup defrost terminate time is fixed at 10 minutes.
2. The compressor recycle delay timer is 5 minutes.
3. The power interrupt response is minimum 17 msec. to maximum 35 msec.
4. Quite shift compressor recycle delay is 30 seconds.

In normal defrost mode, the following sequence will occur after the set delay:

1. Condenser fan off.
2. Reversing valve energized to cooling and auxiliary electric heat (W2) is energized.
3. After defrost sensor opens or a maximum of 10 minutes; the condenser fan is energized (after 20 seconds) and the reversing valve is de-energized to the heat mode. Electric strip heat is also de-energized (after 15 seconds) except as required by the thermostat.
4. Should the system indoor thermostat be satisfied during the defrost cycle, the control will de-energize the reversing valve and auxiliary heat outputs and "hold"

the defrost timer until the next call for heat, at which time the defrost cycle will be completed.

Service testing: the pins marked "speed up" when momentarily shorted together (for 5 seconds) and released, will defeat the 5 minutes recycle delay timer and allow the compressor contactor to be immediately energized, thus forcing a defrost cycle. Termination of this forced mode will be by the defrost thermostat or the 10 minute backup timer, provided the defrost thermostat was closed when the defrost was "forced." If the defrost thermostat was not closed, at the time of the "forced defrost," the defrost mode will remain for 30 seconds and then terminate.

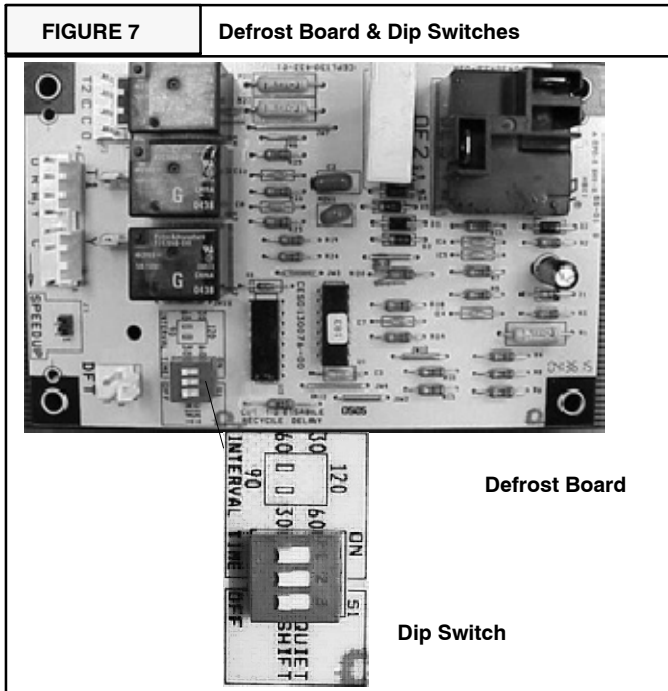

10. MAINTENANCE

MONTHLY MAINTENANCE AND INSPECTION CHECKS

Air Filters



CAUTION

REDUCED EQUIPMENT LIFE HAZARD

Failure to follow this cautions may result in damage to the unit being installed.

Do not operate the unit without a filter.

Inspect filters at least monthly and replace or clean as required. Washable filters may be cleaned by soaking in mild detergent and rinsing with cold water. Replace filters with the arrows on the side pointing in the direction of air flow. Dirty filters are the most common cause of inadequate heating or cooling performance, and of compressor failures.

COOLING SEASON CHECKS (MONTHLY)

Condenser Coil

Keep the condenser inlet and outlet area clean and free of leaves, grass clippings or other debris. Grass should be

kept short in front of the condenser inlet. Shrubbery **MUST** be trimmed back so it is no closer than 30 inches to unit.

Condensate Drain

Check for condensate drainage. Clean as required.

ANNUAL MAINTENANCE AND INSPECTION

⚠ WARNING

ELECTRICAL SHOCK HAZARD.

Failure to follow this warning could result in personal injury, death and/or property damage.

Turn off electric power supply at disconnect switch or service panel before removing any access or service panel from unit.

The annual inspection should include cleaning as required to ensure efficient operation of the unit. To simplify access, remove all access panels and the top from the unit if possible.

Condenser Fan Motor

Note: The condenser fan motor is permanently lubricated. No further lubrication is required. Do not attempt to lubricate the condenser fan motor. Clean the surrounding area and the condenser and evaporator coils. Use caution to avoid damage to coil fins.

BLOWER MOTOR ACCESS

NOTE: Indoor blower motor is 230v single phase, see wiring diagram for details.

Refer to **Figure 1** for blower motor access panel and compartment.

1. Remove the blower access panel.
2. Remove the three screws securing the blower motor housing. If unit has a support bracket, remove the two screws securing the bracket.
3. Remove the two red wires attached to the limit switch and remove the limit switch.

Motor removal and replacement

This method is required to replace or repair blower wheel, blower housing, or any unreachable components behind blower assembly.

1. Remove all screws around rim of unit top, (except screws which are inaccessible because of proximity to structure).
2. Raise unit top at corner of unit closest to blower at least 2" and place a sturdy brace at least 2" thick between top and unit corner. A 2X4 piece of wood is ideal for this.
3. Disconnect all wires from housing and slide housing out of unit. Reverse this process to reinstall.

Circulating Air Blower

Visually inspect the blower wheel for accumulations of dirt or lint. Clean the compartment and the blower wheel. If accumulation is excessive on blower wheel, or does not easily remove, it will be necessary to remove the blower assembly.

Note: The blower motor is permanently lubricated. No further lubrication is required. Do not attempt to lubricate the blower motor.

FIGURE 8

Control Box

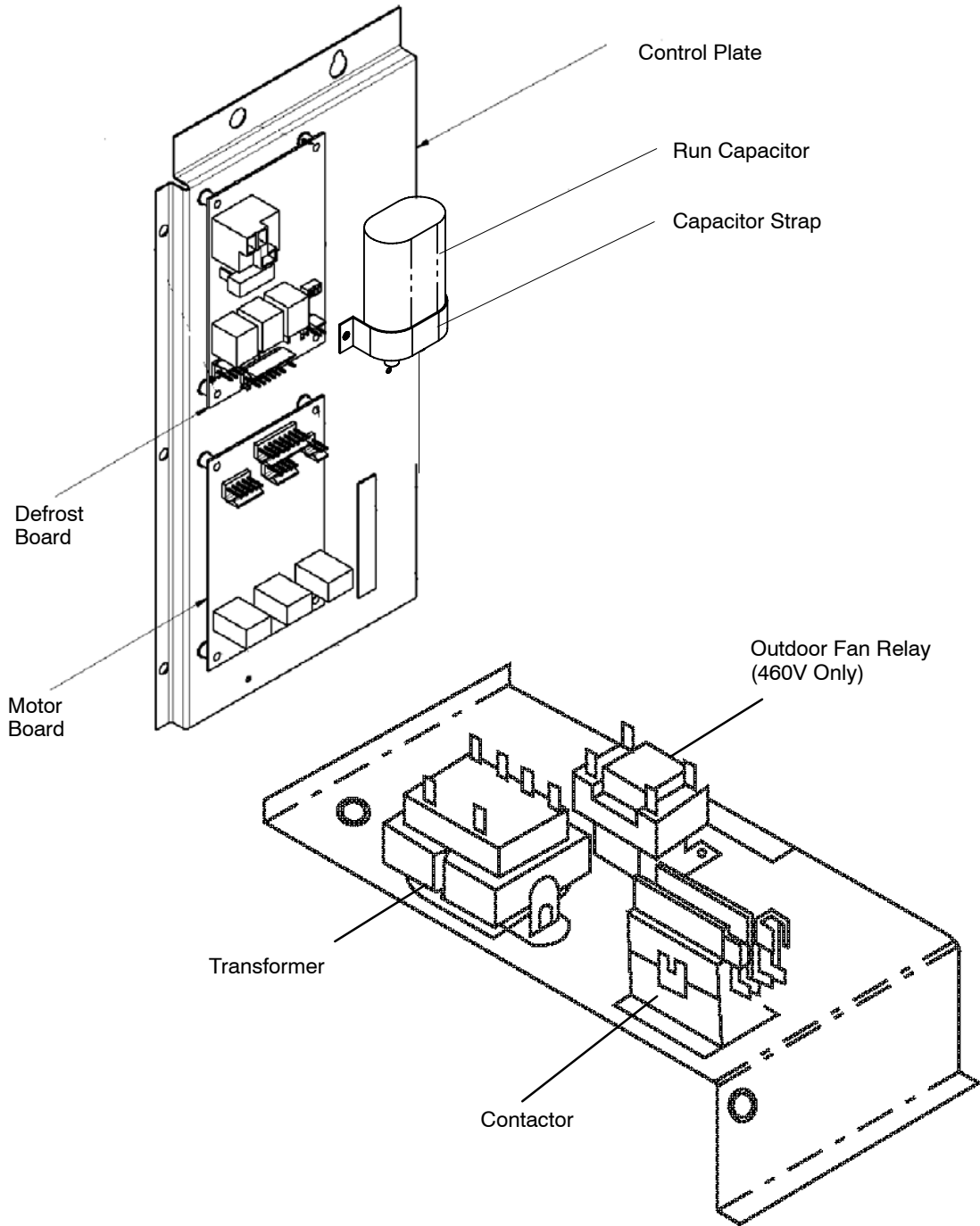

FIGURE 9

Rigging Instructions

1096286

RIGGING INSTRUCTIONS

WARNING
FAILURE TO FOLLOW THESE INSTRUCTIONS CAN RESULT IN PROPERTY DAMAGE, BODILY INJURY OR DEATH.

- ALL PANELS MUST BE IN PLACE WHEN RIGGING AND LIFTING.
- HOOK RIGGING SHACKLES THROUGH HOLES IN BASE RAIL, AS SHOWN IN DETAIL -A.
- USE SPREADER BARS, WHEN RIGGING, TO PREVENT UNIT DAMAGE.
- BE SURE RIGGING AND SHACKLES ARE SUFFICIENT TO HANDLE WEIGHT LISTED BELOW.

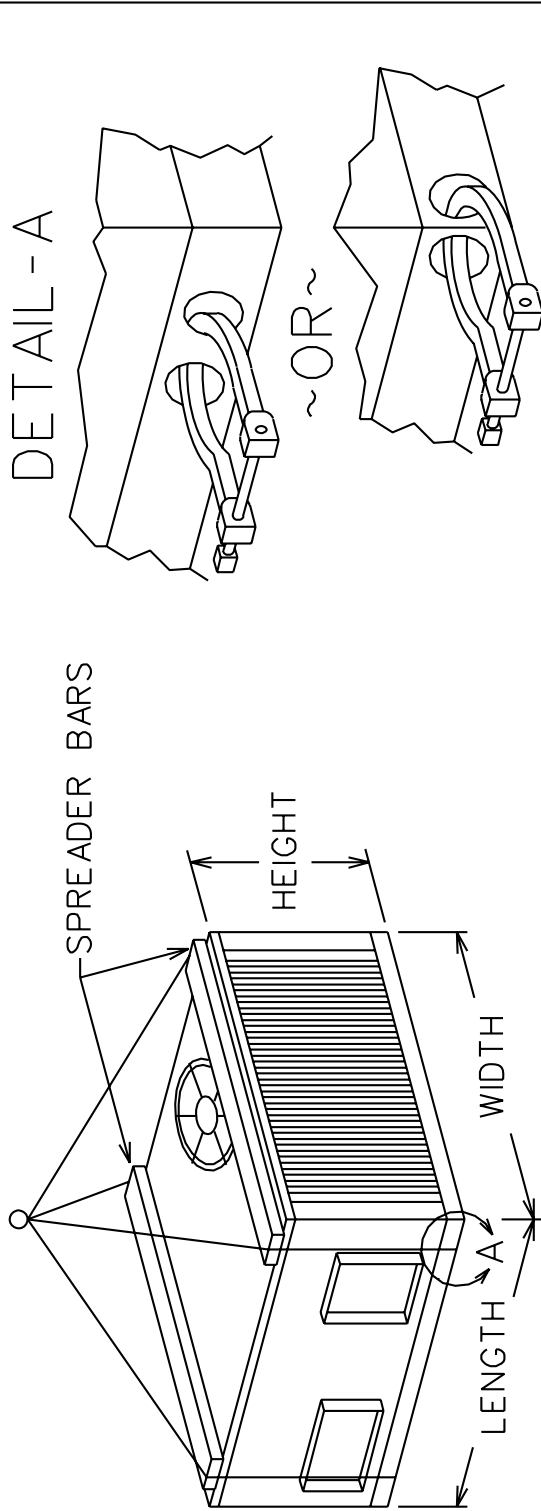

	Max. Length		Max. Width		Max. Height		Max. Weight	
	IN	MM	IN	MM	IN	MM	LB	KG
Cabinet 3 to 4 Ton	48	1219	48	1219	38	965	400	182

10. Wiring Diagrams

3 to 3-1/2 Ton Wiring Diagram - 208/230 Volt

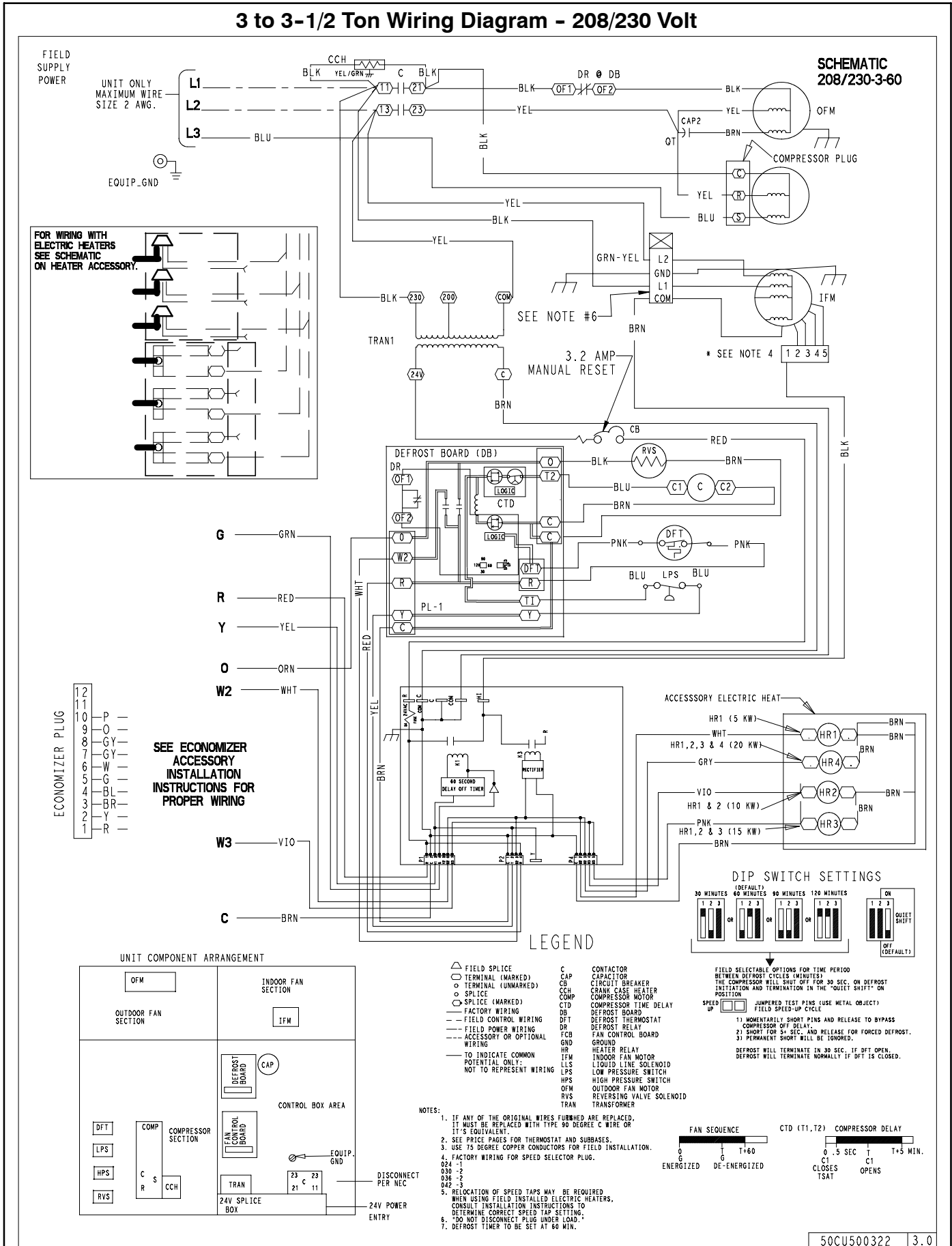

4 Ton Wiring Diagram - 208/230 Volt

**SCHEMATIC
208/230-3-60**

FIELD
SUPPLY
POWER

UNIT ONLY
MAXIMUM WIRE
SIZE 2 AWG.

EQUIP_GND

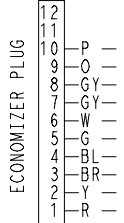
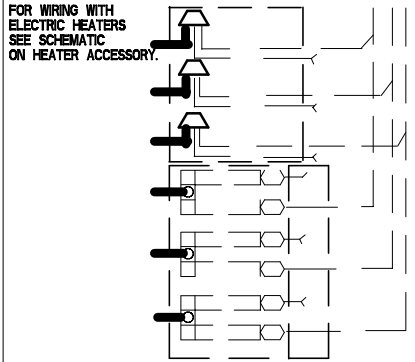

SEE ECONOMIZER
ACCESSORY
INSTALLATION
INSTRUCTIONS FOR
PROPER WIRING

G — GRN
R — RED
Y1 — YEL
O — ORN
W2 — WHT
Y2 — PNK
W3 — VIO
C — BRN

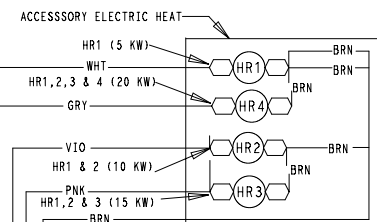
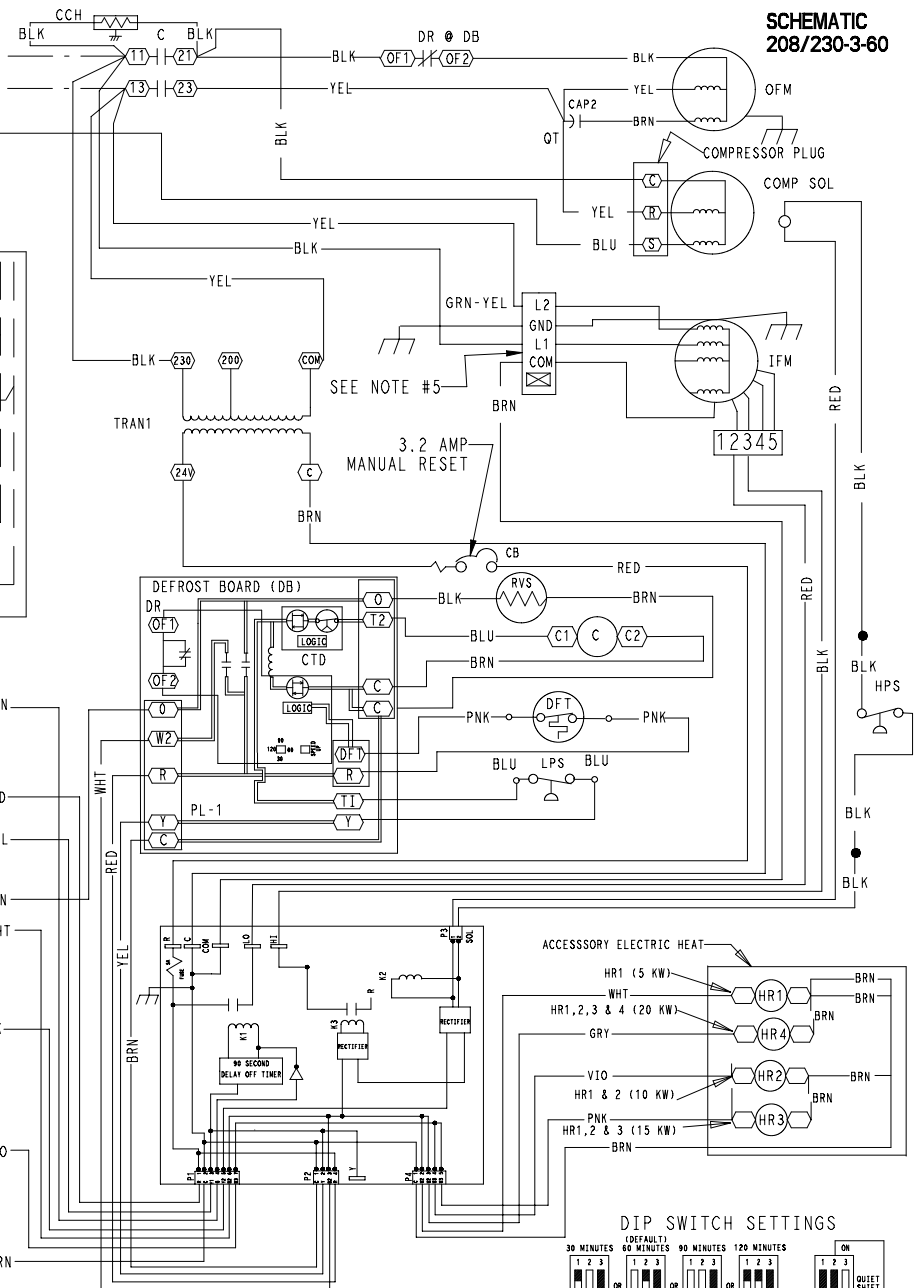

DIP SWITCH SETTINGS

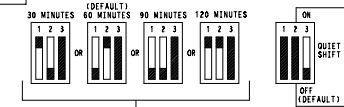

LEGEND

- △ FIELD SPLICE
 - TERMINAL (MARKED)
 - TERMINAL (UNMARKED)
 - SPLICE
 - SPLICE (MARKED)
 - FACTORY WIRING
 - FIELD CONTROL WIRING
 - FIELD POWER WIRING
 - ACCESSORY OR OPTIONAL WIRING
 - TO INDICATE COMMON POTENTIAL ONLY: NOT TO REPRESENT WIRING
- | | | | |
|------|-----------------------|------|--------------------------|
| C | CONTACTOR | CB | CIRCUIT BREAKER |
| CD | CRANK CASE HEATER | COMP | COMPRESSOR MOTOR |
| CTD | COMPRESSOR TIME DELAY | DB | DEFROST BOARD |
| DFT | DEFROST THERMOSTAT | DR | DEFROST RELAY |
| FCB | FAN CONTROL BOARD | GND | GROUND |
| HR | HEATER RELAY | IFM | INDOOR FAN MOTOR |
| LPS | LOW PRESSURE SWITCH | HPS | HIGH PRESSURE SWITCH |
| OFM | OUTDOOR FAN MOTOR | RVS | REVERSING VALVE SOLENOID |
| TRAN | TRANSFORMER | | |

FIELD SELECTABLE OPTIONS FOR TIME PERIOD BETWEEN DEFROST CYCLES (MINUTES)
THE COMPRESSOR WILL SHUT OFF FOR 30 SEC. ON DEFROST INITIATION AND TERMINATION IN THE "QUIET SHIFT" ON POSITION

SPEED UP JUMPERED TEST PINS (USE METAL OBJECT) FIELD SPEED-UP CYCLE

1) MOMENTARILY SHORT PINS AND RELEASE TO BYPASS COMPRESSOR OFF DELAY.
2) SHORT FOR 5+ SEC. AND RELEASE FOR FORCED DEFROST.
3) PERMANENT SHORT WILL BE IGNORED.

DEFROST WILL TERMINATE IN 30 SEC. IF DFT OPEN, DEFROST WILL TERMINATE NORMALLY IF DFT IS CLOSED.

UNIT COMPONENT ARRANGEMENT

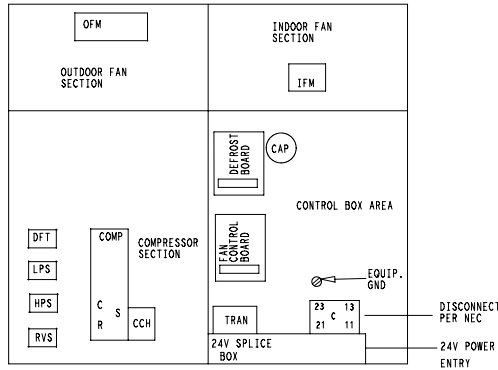

- NOTES:
- IF ANY OF THE ORIGINAL WIRES FURNISHED ARE REPLACED, IT MUST BE REPLACED WITH TYPE 90 DEGREE C WIRE OR IT'S EQUIVALENT.
 - SEE PRICE PAGES FOR THERMOSTAT AND SUBBASES.
 - USE 75 DEGREE COPPER CONDUCTORS FOR FIELD INSTALLATION.
 - DEFROST TIMER TO BE SET AT 60 MIN.
 - RELOCATION OF SPEED TAPS MAY BE REQUIRED WHEN USING FIELD INSTALLED ELECTRIC HEATERS. CONSULT INSTALLATION INSTRUCTIONS TO DETERMINE CORRECT SPEED TAP SETTING.
 - *DO NOT DISCONNECT PLUG UNDER LOAD.*

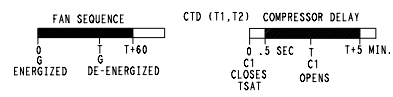

50CU500323 3.0

3 to 3-1/2 Ton Wiring Diagram - 460 Volt

**SCHEMATIC
460-3-60**

FIELD
SUPPLY
POWER

UNIT ONLY
MAXIMUM WIRE
SIZE 2 AWG.

EQUIP_GND

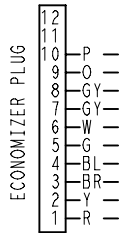
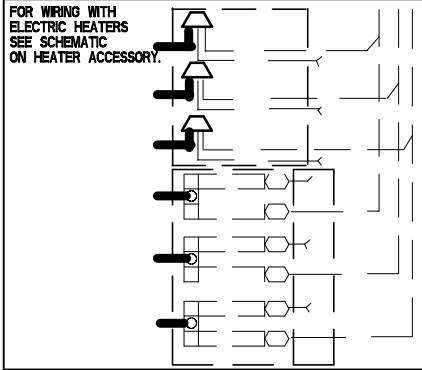

**SEE ECONOMIZER
ACCESSORY
INSTALLATION
INSTRUCTIONS FOR
PROPER WIRING**

G — GRN

R — RED

Y — YEL

O — ORN

W2 — WHT

W3 — VIO

C — BRN

UNIT COMPONENT ARRANGEMENT

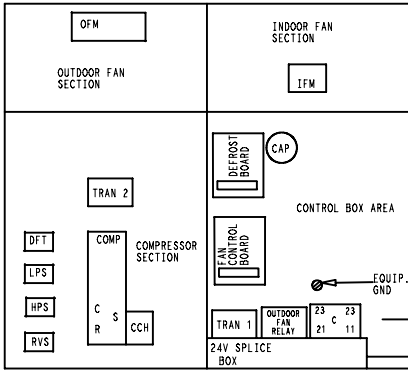

DISCONNECT
PER NEC

24V POWER
ENTRY

- LEGEND**
- △ FIELD SPICE
 - TERMINAL
 - SPICE
 - FACTORY WIRING
 - - - FIELD POWER WIRING
 - - - ACCESSORY OR OPTIONAL WIRING
 - TO INDICATE COMMON POTENTIAL ONLY. NOT TO REPRESENT WIRING
- C CAP
 - CB CIRCUIT BREAKER
 - CCH CRANK CASE HEATER
 - COMP COMPRESSOR MOTOR
 - CTD COMPRESSOR TIME DELAY
 - DB DEFROST BOARD
 - DFT DEFROST THERMOSTAT
 - DR DEFROST RELAY
 - FCB FAN CONTROL BOARD
 - GND GROUND
 - HR HEATER RELAY
 - IFM INDOOR FAN MOTOR
 - LLS LIQUID LINE SOLENOID
 - LPS LOW PRESSURE SWITCH
 - HPS HIGH PRESSURE SWITCH
 - OFM OUTDOOR FAN MOTOR
 - OFR OUTDOOR FAN RELAY
 - RVS REVERSING VALVE SOLENOID
 - TRAN 1 TRANSFORMER 460-24
 - TRAN 2 TRANSFORMER 460-230

NOTES:

1. IF ANY OF THE ORIGINAL WIRES FURNISHED ARE REPLACED, IT MUST BE REPLACED WITH TYPE 90 DEGREE C WIRE OR ITS EQUIVALENT.
2. SEE PRICE PAGES FOR THERMOSTAT AND SUBBASES.
3. USE 15 DEGREE COPPER CONDUCTORS FOR FIELD INSTALLATION.
4. FACTORY WIRING FOR SPEED SELECTOR PLUG.
5. RELOCATION OF SPEED TAPS MAY BE REQUIRED WHEN USING FIELD INSTALLED ELECTRIC HEATERS. CONSULT INSTALLATION INSTRUCTIONS TO DETERMINE CORRECT SPEED TAP SETTING.
6. "DO NOT DISCONNECT PLUG UNDER LOAD."
7. DEFROST TIMER TO BE SET AT 60 MIN.

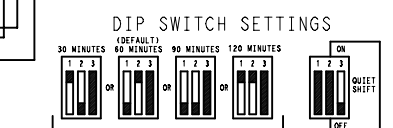
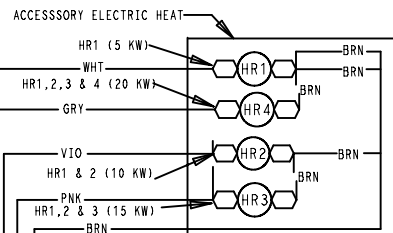
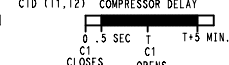
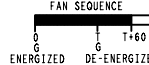

FIELD SELECTABLE OPTIONS FOR TIME PERIOD BETWEEN DEFROST CYCLES (MINUTES):
 1) MOMENTARILY SHORT PINS (USE METAL OBJECT) TO BYPASS COMPRESSOR OFF DELAY.
 2) SHORT FOR 5 SEC. AND RELEASE FOR FORCED DEFROST.
 3) PERMANENT SHORT WILL BE IGNORED.
 DEFROST WILL TERMINATE IN 30 SEC. IF DFT OPEN. DEFROST WILL TERMINATE NORMALLY IF DFT IS CLOSED.

50CU500362 5.0

4 Ton Wiring Diagram - 460 Volt

SCHEMATIC 460-3-60

FIELD SUPPLY POWER

UNIT ONLY
MAXIMUM WIRE
SIZE 2 AWG.

EQUIP_GND

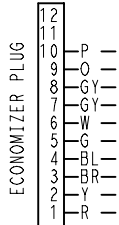
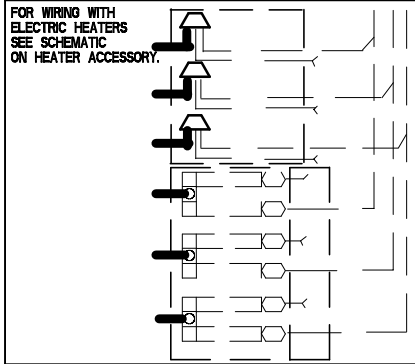

SEE ECONOMIZER ACCESSORY INSTALLATION INSTRUCTIONS FOR PROPER WIRING

- G — GRN
- R — RED
- Y1 — YEL
- O — ORN
- W2 — WHT
- Y2 — PNK
- W3 — VIO
- C — BRN

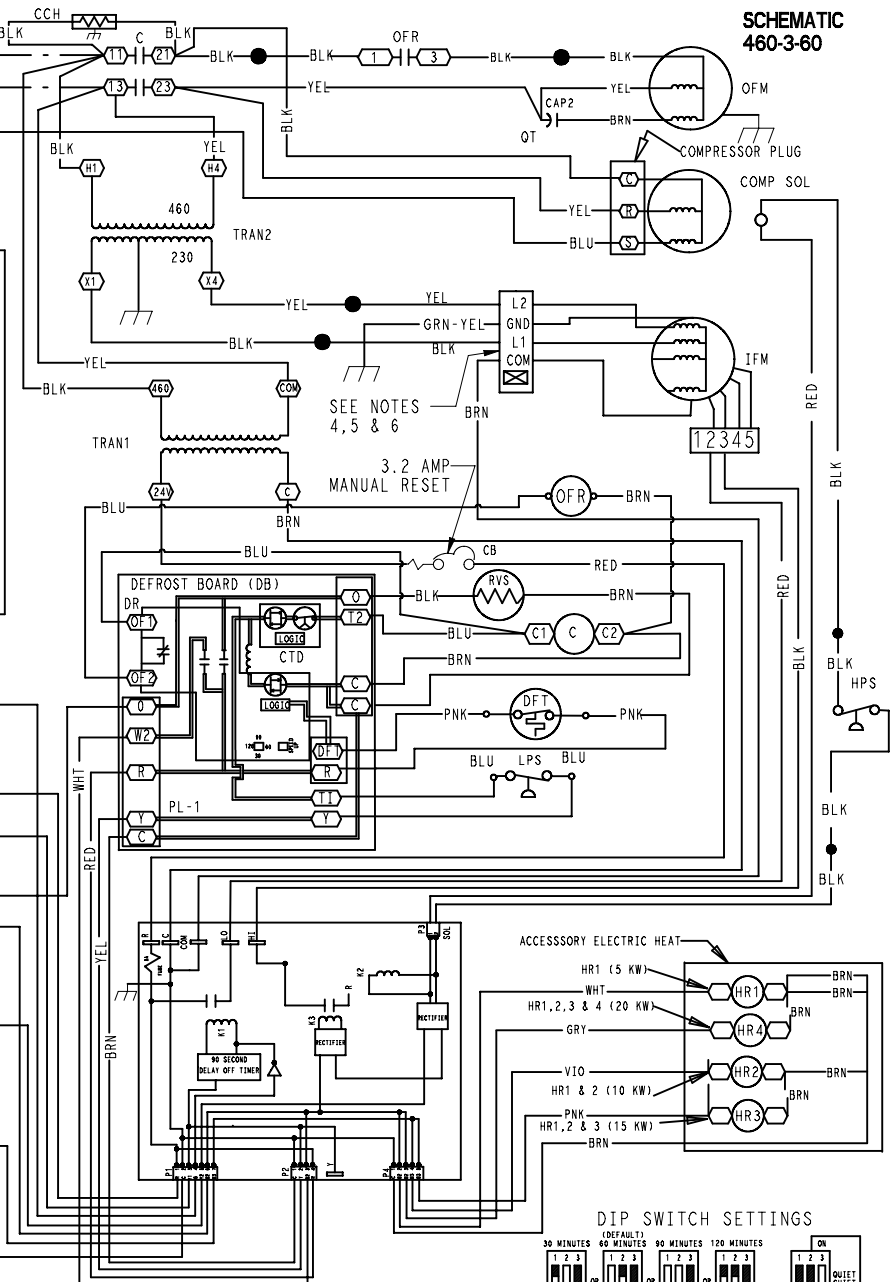

UNIT COMPONENT ARRANGEMENT

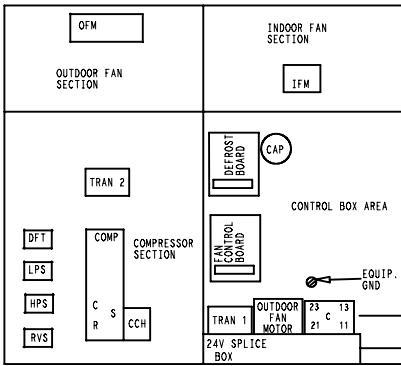

LEGEND

- △ FIELD SPLICE
- TERMINAL
- SPLICE
- FACTORY WIRING
- - - FIELD CONTROL WIRING
- - - FIELD POWER WIRING
- - - ACCESSORY OR OPTIONAL WIRING
- - - TO INDICATE COMMON POTENTIAL ONLY; NOT TO REPRESENT WIRING
- C CONTACTOR
- CAP CAPACITOR
- CB CIRCUIT BREAKER
- CCH CRANK CASE HEATER
- COMP COMPRESSOR MOTOR
- CTD COMPRESSOR TIME DELAY
- DB DEFROST BOARD
- DFT DEFROST THERMOSTAT
- DR DEFROST RELAY
- FCB FAN CONTROL BOARD
- GND GROUND
- HR HEATER RELAY
- IFM INDOOR FAN MOTOR
- LPS LOW PRESSURE SWITCH
- HPS HIGH PRESSURE SWITCH
- OFM OUTDOOR FAN MOTOR
- OFR OUTDOOR FAN RELAY
- RVS REVERSING VALVE SOLENOID
- TRAN TRANSFORMER

NOTES:

- IF ANY OF THE ORIGINAL WIRES FURNISHED ARE REPLACED, IT MUST BE REPLACED WITH TYPE 90 DEGREE C WIRE OR ITS EQUIVALENT.
- SEE PRICE PAGES FOR THERMOSTAT AND SUBBASES.
- USE 75 DEGREE COPPER CONDUCTORS FOR FIELD INSTALLATION.
- DEFROST TIMER TO BE SET AT 60 MIN.
- RELOCATION OF SPEED TAPS MAY BE REQUIRED WHEN USING FIELD INSTALLED ELECTRIC HEATERS. CONSULT INSTALLATION INSTRUCTIONS TO DETERMINE CORRECT SPEED TAP SETTING.
- "DO NOT DISCONNECT PLUG UNDER LOAD."

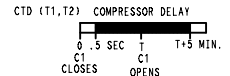
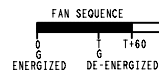

50CU500366 5.0