

USER'S INFORMATION MANUAL

CONDENSING GAS FURNACE

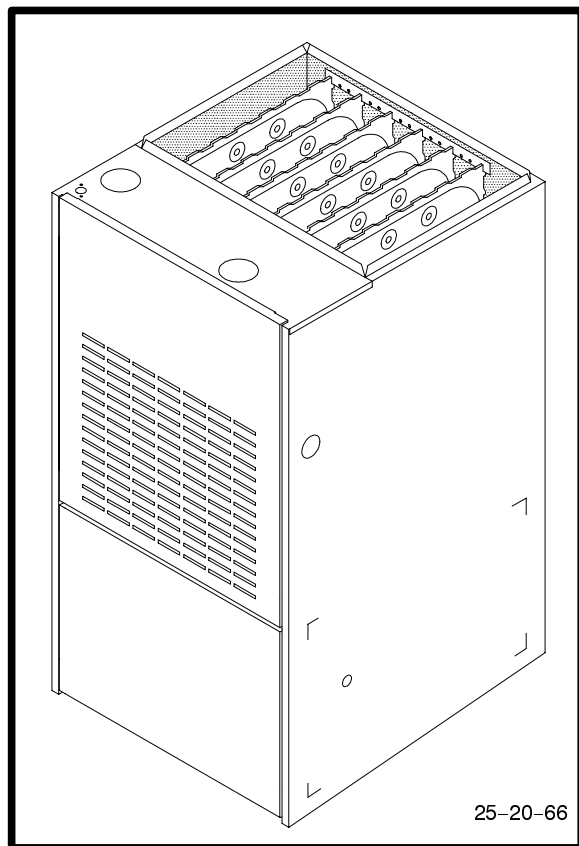

! WARNING

Fire or explosion hazard.

Information in this manual **MUST** be followed exactly.

Failure to follow the information in this manual exactly could result in property damage, bodily injury, or death.

- Do not store or use gasoline or other flammable vapors and liquids in the vicinity of this or any other appliance.
- **WHAT TO DO IF YOU SMELL GAS**
 - Do not try to light any appliance.
 - Do not touch any electrical switch; do not use any phone in your building.
 - Immediately evacuate the building and call your gas supplier from a phone outside the building. Follow the gas supplier's instructions.
 - If you cannot reach your gas supplier, call the fire department.
- Installation and service must be performed by a qualified installer, service agency or the gas supplier.



Printed in U.S.A.

Manufactured by:

International Comfort Products Corporation (USA)
Lewisburg, TN USA 37091

LP2

441 02 1301 01 (8/12/97)
Replaces 441 02 1301 00

Contents

Danger, Warning and Caution 2
Safety Rules 3
Combustion Air (Your safety) 3

Operating Your Unit 5
Unit Maintenance 6

Danger, Warning and Caution

The signal words **DANGER**, **WARNING** and **CAUTION** are used to identify levels of hazard seriousness. The signal word **DANGER** is only used on product labels to signify an immediate hazard. The signal words **WARNING** and **CAUTION** will be used on product labels and throughout this manual and other manuals that may apply to the product.

Signal Words

DANGER – Immediate hazards which **WILL** result in severe personal injury or death.

WARNING – Hazards or unsafe practices which **COULD** result in severe personal injury or death.

CAUTION – Hazards or unsafe practices which **COULD** result in minor personal injury or product or property damage.

Signal Words in Manuals

The signal word **WARNING** is used throughout this manual in the following manner:



The signal word **CAUTION** is used throughout this manual in the following manner:

CAUTION

Product Labeling

Signal words are used in combination with colors and/or pictures on product labels. Following are examples of product labels with explanations of the colors used.

Danger Label

White lettering on a black background except the word **DANGER** which is white with a red background.



Warning Label

White lettering on a black background except the word **WARNING** which is black with an orange background.



Caution Label

White lettering on a black background except the word **CAUTION** which is black with a yellow background.

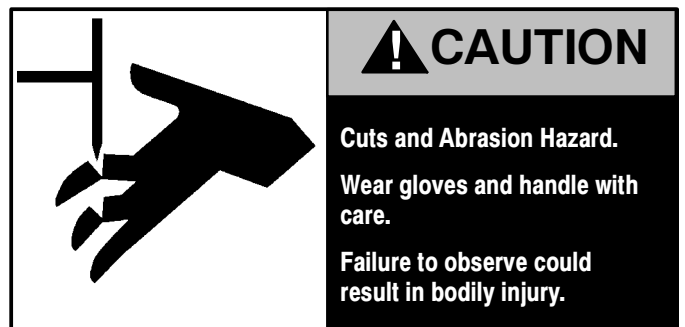

⚠ WARNING

Read this manual and follow its instructions and adhere to all Cautions and Warnings in the manual and on the unit. Consult a qualified service technician for installation, adjustment and maintenance.

Failure to observe and follow Cautions, Warnings and instructions may result in property damage, bodily injury or death.

Safety Rules

Your unit is built to provide many years of safe and dependable service providing it is properly installed and maintained. However, abuse and/or improper use can shorten the life of the unit and create hazards for you, the owner.

- A. The U.S. Consumer Product Safety Commission recommends that users of gas-burning appliances install carbon monoxide detectors. There can be various sources of carbon monoxide in a building or dwelling. The sources could be gas-fired clothes dryers, gas cooking stoves, water heaters, furnaces, gas-fired fireplaces, wood fireplaces, and several other items. Carbon monoxide can cause serious bodily injury and/or death. Therefore, to help alert people of potentially dangerous carbon monoxide levels, you should have carbon monoxide detectors listed by a nationally recognized agency (e.g. Underwriters Laboratories or International Approval Services) installed and maintained in the building or dwelling (see Note below).
- B. There can be numerous sources of fire or smoke in a building or dwelling. Fire or smoke can cause serious bodily injury, death, and/or property damage. Therefore, in order to alert people of potentially dangerous fire or smoke, you should have fire and smoke detectors listed by Underwriters Laboratories installed and maintained in the building or dwelling (see Note below).

Note: The manufacturer of your furnace does not test any detectors and makes no representations regarding any brand or type of detector.

- C. To ensure safe and efficient operation of your unit, you should do the the following:
 1. **Thoroughly read this manual and labels on the unit.** This will help you understand how your unit operates and the hazards involved with gas and electricity.

2. **Do not use this unit if any part has been under water.** Immediately call a qualified service technician to inspect the unit and to replace any part of the control system and any gas control which has been under water.
3. **Never obstruct the vent grilles, or any ducts that provide air to the unit.** Air must be provided for proper combustion and ventilation of flue gases.
4. **Familiarize yourself with the possible air starvation signals.** These are outlined in the Combustion Air section.
5. **Check the combustion air supply.** Some models use air drawn from outside. Other models and other appliances use combustion air from inside the structure. Air starvation signals are listed in section titled "Combustion Air". If any of the signals are noticed, perform a combustion air check as shown in section titled "Combustion Air Checks" or call a service technician. If you add weather stripping, storm windows, insulation, an additional fuel burning appliance, or remodel the structure, a combustion air check **MUST** be accomplished after the addition.
6. **Maintain safety and service clearances from the unit.** These are listed on the Rating Plate on the unit and in the "Installation Manual". Keep the unit area clean and free of combustible materials at all times. Never store gasoline, paint, aerosol cans, waxes, bleaches, dry cleaning fluid or items such as paper or rags near the unit.
7. **Familiarize yourself with all controls.** Make sure you know how to shut off the gas and the electrical power to the unit. If the unit is to be shut down for an extended length of time (example; remodeling project), turn off both the gas and the electrical power. For safety, always turn them off before performing service or maintenance on the unit.
8. **Establish a regular service and maintenance schedule.** This will ensure efficient and safe operation of the unit. It is recommended that you have a qualified service agency perform a complete check on the unit before each heating season. See unit Maintenance "Service Technician Checks".
9. **Inspect insulation. Insulation is combustible.** If your furnace is located in an attic or other space near insulation, periodically inspect to insure space around furnace is free and clear of insulating material. If furnace is newly installed, make a through check around furnace. If adding insulation to a space with a furnace, also check that furnace is free and clear of insulating material.
10. **Keep air openings clear.** Do not block any air openings on the furnace, openings connecting to furnace area, and spaces around the furnace.

Combustion Air (Your Safety)

! WARNING

All fuel-burning appliances must be provided with enough fresh air for proper combustion and ventilation of flue gases.

Some models use air from the space in which they are located, and other appliances in the same space may also be using indoor air for ventilation and/or combustion.

Lack of combustion air will result in carbon monoxide gas which could cause serious bodily injury or death.

New materials and methods are being used in construction and remodeling which result in lower energy costs for heating and cooling. It may also mean your appliances may not be getting enough air for combustion and ventilation of flue gases. The use of exhaust fans, fireplaces, clothes dryers, and other appliances consume air or vent it outside.

If the appliances or heating unit can't get enough air, two conditions may result:

1. The appliance or heating unit may produce carbon monoxide gas.

Carbon monoxide or "CO" is a colorless and odorless gas produced when fuel is not burned completely or when the flame does not receive sufficient oxygen.

2. The appliance may not vent flue gases properly.

The following are signs that your appliances may not be getting enough air for proper combustion.

Be aware of these signals;

1. Headaches–Nausea–Dizziness
2. Excessive humidity–Heavily frosted windows or a moist "clammy" feeling in the structure .
3. Smoke from the fireplace won't draw up the chimney.

! WARNING

If you experience headaches, nausea, or dizziness, carbon monoxide may be present.

Leave the house immediately and call your gas supplier.

Carbon monoxide poisoning can result in serious bodily injury or death from asphyxiation.

Combustion Air Checks

If any of the signals are noticed, perform a combustion air check or call a service technician. If you add weather stripping, storm windows, insulation, an additional fuel burning

appliance, or remodel the structure, a combustion air check **MUST** be accomplished after the addition.

Make the inspection as follows:

1. Close all doors and windows. If you have a fireplace, start a fire and wait until flames are burning vigorously.
2. Turn on all exhausting devices, such as: kitchen and bathroom exhaust fans and dryers (gas or electric).
3. Turn on all vented gas appliances, such as: heating equipment (includes any room heaters) and water heaters.
4. Wait ten (10) minutes for drafts to stabilize.
5. On appliances with a draft hood, check for spillage by holding a lighted match 2 inches from the draft hood opening. Reference **Figure 1** which shows a water heater draft hood.

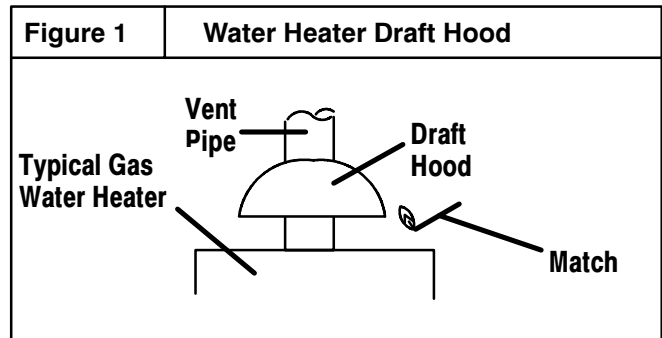

- A. *Match flame pulls toward draft hood.* This indicates no spillage and that appliance is getting enough air for combustion. Return exhausting devices and appliances to the condition you found them .
- B. *Match goes out or flame wavers away from draft hood.* This indicates spillage and that appliance is not getting enough air for combustion.

! WARNING

Draft hood spillage means there is not enough air for proper combustion and carbon monoxide may be present.

Keep a window open (a minimum of 2 ") near the appliance until a permanent air duct is installed. Contact a qualified service agency.

Carbon monoxide poisoning can result in serious bodily injury or death from asphyxiation.

If draft hood spillage is indicated:

1. Check for plugged flue connectors and chimneys. Repair stoppage and test again.
2. If you have a fireplace, open a window or door near the fireplace and then check for spillage. If spillage stops, do not use the fireplace until you can supply fresh air by a permanent duct.

3. If you have kitchen and bathroom exhaust fans, turn them **OFF** and check for spillage. If spillage stops, do not use exhaust fans until you can supply fresh air by a permanent duct. Circuit breakers for fans should be turned off.
4. Spillage means air starvation and a fresh air duct or

air intakes must be installed to provide air directly to the area around the unit. These **MUST** comply with local and state building codes or in their absence with the National Fuel Gas Code NFPA 54/ANSI Z223.1, current edition or in Canada the National Standard CAN/CGA 1-B149.

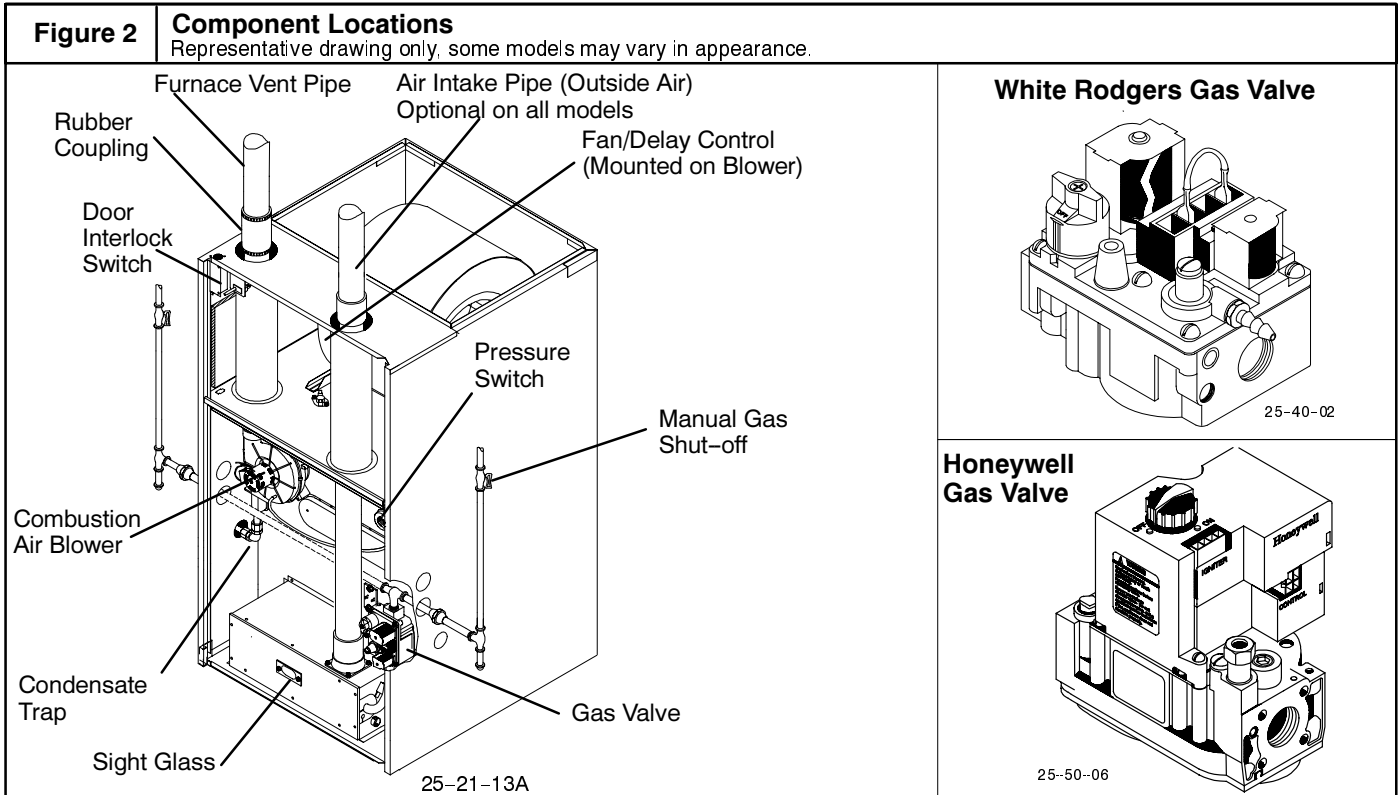

Operating Your Unit

Keep the blower access door and all access panels in place except for inspection or maintenance.

Before starting your unit be sure you read and understand all of the procedures in this manual. Check to make sure the unit filter is clean and correctly installed.

Should overheating occur or the gas supply fail to shut off, shut off the manual gas valve to the unit before shutting off the electrical supply.

⚠ WARNING

Carbon monoxide Poisoning Hazard.
Provisions for combustion and ventilation air must be provided for in accordance with installations instructions supplied with unit.
Failure to provide adequate combustion and ventilation air can result in personal injury and/or death.

Starting Unit

Please refer to “lighting instructions” or “operating instructions” label on furnace for detailed instructions on starting the furnace.

Turning Off The Unit

Set the thermostat to the lowest setting or set System Select Switch to **OFF** if equipped.

If furnace is to be turned off for an extended period of time, electricity and gas should be turned off to furnace.

Please refer to label on unit for detailed instructions to turn off gas to appliance.

L P Model Units

If your L.P. (liquefied petroleum) gas unit is installed in a an excavated or low lying area, we recommend that you contact your L.P. supplier about installing a warning device that would alert you of a gas leak.

⚠ WARNING

Fire or explosion hazard.
L.P. gas is heavier than air. Leaking gas can settle in low areas such as a crawl space. If you suspect the presence of gas, follow the instructions on the cover of this manual.
Failure to observe could result in property damage, bodily injury or death.

Freezing Temperatures And Your Structure

Your unit is equipped with safety devices that may keep it from operating if sensors detect abnormal conditions such as clogged exhaust flues.

If your unit remains shut off during cold weather the water pipes could freeze and burst, resulting in serious water damage.

If the structure will be unattended during cold weather you should take these precautions.

1. Turn off main supply water into the structure and drain the water lines if possible. Open faucets in appropriate areas.
2. Have someone check the structure frequently during cold weather to make sure it is warm enough to prevent pipes from freezing. Suggest they call qualified service agency, if required.

Unit Maintenance

Have your unit inspected and serviced on an annual basis (before the heating season) by a qualified service technician.

! WARNING

Electrical shock hazard.

Turn off electric power to unit before performing any maintenance or removing panels or doors.

Failure to observe could result in bodily injury or death.

Air Filters

The air filter(s) should be inspected at least monthly and cleaned or replaced as required. There are two types of filters that are commonly used. The most widely used is the Fiberglass disposable type which should be **REPLACED** before it becomes clogged. The other type is the washable type constructed of aluminum mesh, foam, or reinforced fibers. Washable filters may be cleaned by soaking in mild detergent and rinsing with water.

! WARNING

Fire hazard from dust and lint buildup on internal unit parts.

Never operate unit without a filter installed.

Failure to observe could result in bodily injury or death.

Remember that dirty filters are the most common cause of inadequate heating or cooling performance.

| Figure 3 | | Recommended Filter Sizes | |
|--|--|--|------------------------|
| Unit Size Heating Input 1000 x Btuh | Nominal Air Flow Cubic Feet per Minute (CFM) | Recommended Filter Sizes Sq. In. Surface Area/Nominal Size (inches) | |
| | | Disposable Filters | Cleanable Filters |
| 40 - 50 | 800-900 | 500 or 20 x 25 | 350 or 14 x 25 |
| 40 - 50, 75, and 100 | 900-1100 | 600 or 20 x 30 | 350 or 14 x 25 |
| 40 - 50, 75, and 100 | 1100-1300 | 350 or 14 x 25 (2Req.) | 350 or 14 x 25 |
| 75,100, and 125 | 1300-1500 | 400 or 16 x 25 (2Req.) | 400 or 16 x 25 (2Req.) |
| 100 and 125 | 1500-1700 | 500 or 20 x 25 (2 Req.) | 500 or 20 x 25 |
| 125 | 1900-2100 | 600 or 20 x 30 (2 Req.) | 500 or 20 x 25 |
| 150 | 2300-2500 | 600 or 20 x 30 (2 Req.) | 720 or 24 x 30 |

Replacement Filters

Figure 3 lists recommended sizes and types of filters that may be used with your unit, based on the input rating and Btuh.

Replacement filters should be of the same type and size as the originals, to ensure adequate air flow and filtering. A disposable low velocity filter though, can be replaced with a washable high velocity type. *Do not replace a high velocity filter with a disposable low velocity filter.*

Filter Replacement - Upflow and Horizontal

These units come with a filter rack and filter. The filter rack may be installed in the bottom of the blower compartment,

or on the outside on either side of the unit. A plastic endcap is inserted in the filter rack after the filter is installed. The endcap keeps air from escaping around the open end of the filter rack. See **Figure 4** for filter rack, filter and endcap locations.

Filter racks attached to the unit are made so the filter simply slides out one side for removal.

1. Remove the endcap from the filter rack.
2. Slide the filter out of the filter rack.
3. Inspect the filter(s) and replace or clean washable types. If filter is aluminum mesh it should be re-coated with filter coating spray.

- Reinstall the filter in the filter rack.
Some filters are marked with an arrow to indicate the proper direction of air flow through the filter. The air flow direction will be towards the blower motor. Make sure filter is installed correctly.

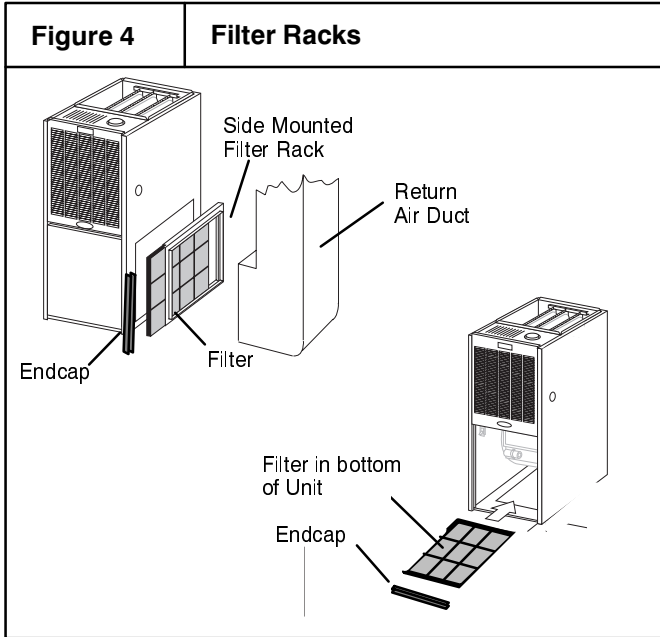

- Reinstall the endcap in the filter rack.

Filter Replacement - Counterflow

These units come with a filter rack and filters. The filter rack should be installed in the top of the unit. To remove filter, refer to **Figure 5** for the following steps.

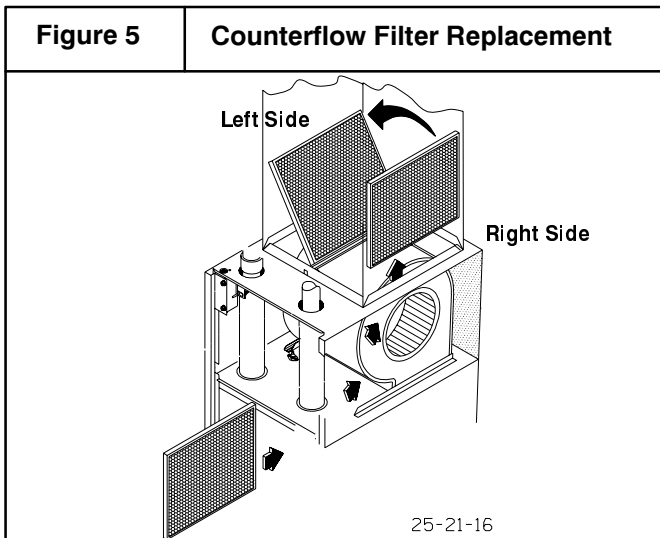

- Turn off the gas and electrical power to the furnace.
- Remove compartment door.
- Reach up above right side of blower and lift dirty filters out of rack at top of furnace.
- Straighten up filters and pull straight down at side of blower. Pull out through right side of door opening.

- Inspect the filter(s) and replace or clean washable types. If filter is aluminum mesh it should be re-coated with filter coating spray.
- Reinstall the filter in the filter rack.
Some filters are marked with an arrow to indicate the proper direction of air flow through the filter. The air flow direction will be towards the blower motor. Make sure filter is installed correctly.
- Reinstall compartment door.
- Turn on the gas and electrical power to the furnace.

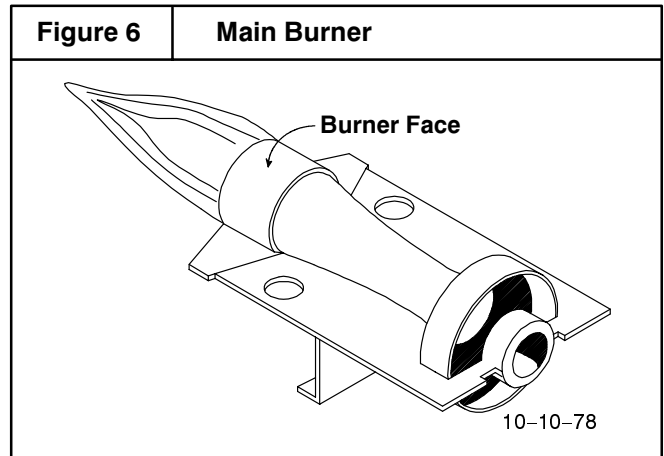

Pilot Flame

While the main burner is **ON**, the flame should envelop the upper part of the Flame Sensor, as shown in **FIGURE 6A**.

Contact a qualified service agency at once if an abnormal flame appearance is identified.

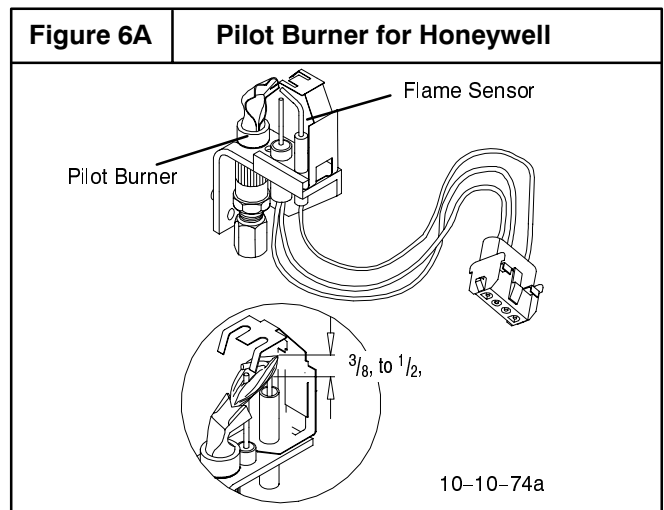

Lubrication

The circulating blower motor and combustion air blower **do not** require lubrication.

Monthly Inspection

A properly adjusted gas unit should not require cleaning at frequent intervals, but it should be inspected regularly to

ensure safe and efficient operation. A brief monthly inspection is recommended that does not require disassembly. In addition you should have the unit inspected, and cleaned if required, by a qualified service technician annually.

Note: Step 7 is only required for furnaces equipped with a pilot. Your unit may or may not have a pilot. Furnaces with a pilot will have a metal tube attached to the gas valve. Follow the metal tube to the pilot. The pilot is located between two of the burners.

1. Check the vents to be sure they are clear and free of obstructions.
2. Check that the vent connector is in place, slopes upward away from furnace, and is physically sound without holes or excessive corrosion.
3. Check return air duct to make sure it is sealed to unit casing, terminates outside the space containing the furnace, and that it is in good physical condition.
4. Inspect the unit base. All supports for furnace should be structurally sound without sags, cracks, gaps, etc. between the furnace and the base.
5. Remove the front panel and use a flashlight to inspect the visible part of the heat exchanger and main burners. Check for loose soot and give particular attention to obvious deterioration from corrosion or other sources. If soot or deterioration is found inside the unit **DO NOT OPERATE UNIT**; call a qualified service technician.
6. Inspect main burner flames for the following:
 - Stable and blue flames. Dust may cause orange tips or wisps of yellow, but flames must not have solid yellow tips.
 - Flames extending directly from burner into heat exchanger.
 - Flames do not touch sides of heat exchanger.

If abnormal flame appearance is identified do not operate unit; call a qualified service technician.

7. Inspect pilot flame (if equipped). While main burner is on, the flame should envelop the upper part of the flame sensor as shown in **Figure 6A**. Contact a qualified service technician if an abnormal flame appearance is identified.
8. Inspect the drain line and overflow line monthly. If a condensate neutralizer cartridge is used and becomes plugged, the condensate will flow through the overflow line. If this happens, clean both cartridge and drain lines. To clean, disconnect and unscrew end cap from cartridge. Pour the neutralizer out and flush neutralizer and inside of cartridge with water. Pour neutralizer back, adding neutralizer if cartridge is less than $\frac{3}{4}$ full. See replacement parts for neutralizer.

Service Technician Checks

When the unit is being inspected for condition and operation have the Service Technician check the following items.

1. Check that adequate combustion air is being supplied to the unit by the air openings into or from the unit.
2. Check all flue gas passages including main and pilot burners, heat exchanger, and vent .
3. Check gas pipe and all connections inside and leading to the unit for leaks.
4. Check electrical wiring and connections.
5. Check supply and return air ducts for leakage, blockage and connections to unit.
6. Check circulating air blower wheel and motor. Clean them if required.
7. Perform an operational checkout on the unit to be sure safety controls function and that unit operates properly.

For additional information the Service Technician can consult the Installation Instructions and applicable Technical Support Manual for the unit.