

User's Information Manual

⚠ WARNING

Fire or explosion hazard.

Information in this manual MUST be followed exactly.

Failure to follow the information in this manual exactly could result in death, bodily injury and/or property damage.

-- Do not store or use gasoline or other flammable vapors and liquids in the vicinity of this or any other appliance.

-- WHAT TO DO IF YOU SMELL GAS

- Do not try to light any appliance.
- Do not touch any electrical switch; do not use any phone in your building.
- Immediately evacuate the building and call your gas supplier from a phone outside the building. Follow the gas supplier's instructions.
- If you cannot reach your gas supplier, call the fire department.

-- Installation and service must be performed by a qualified installer, service agency or the gas supplier.

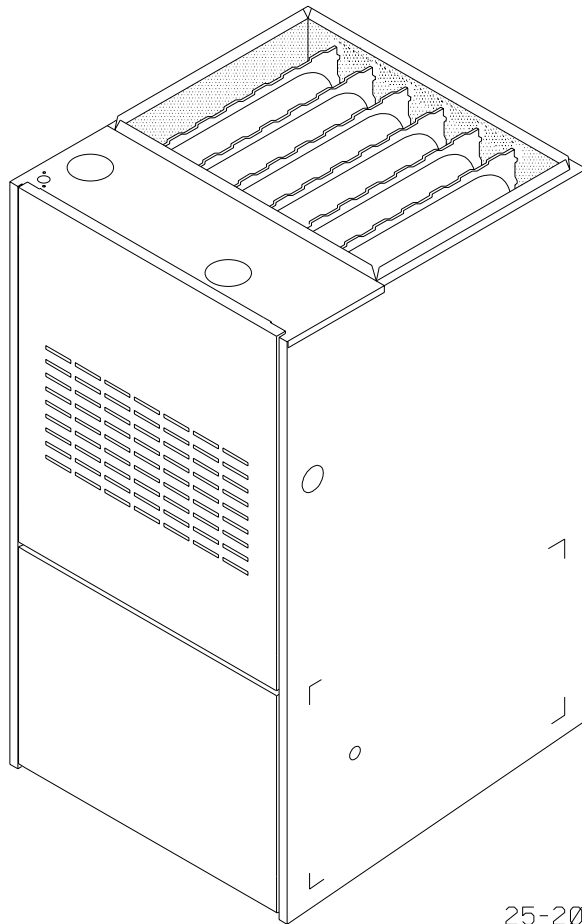

25-20-66



Condensing Gas Furnaces

Manufactured by:

International Comfort Products Corporation (USA)

Lewisburg, TN USA 37091

Contents

Danger, Warning and Caution	2	About Your Unit	4
Safety Rules	3	Operating Your Unit	6
Combustion Air (Your safety)	3	Unit Maintenance	7
Indoor Humidity (Your Comfort)	4		

Danger, Warning and Caution

The signal words **DANGER**, **WARNING** and **CAUTION** are used to identify levels of hazard seriousness. The signal word **DANGER** is only used on product labels to signify an immediate hazard. The signal words **WARNING** and **CAUTION** will be used on product labels and throughout this manual and other manuals that may apply to the product.

Signal Words

DANGER – Immediate hazards which **WILL** result in severe personal injury or death.

WARNING – Hazards or unsafe practices which **COULD** result in severe personal injury or death.

CAUTION – Hazards or unsafe practices which **COULD** result in minor personal injury or product or property damage.

Signal Words in Manuals

The signal word **WARNING** is used throughout this manual in the following manner:



The signal word **CAUTION** is used throughout this manual in the following manner:

CAUTION

Product Labeling

Signal words are used in combination with colors and/or pictures on product labels. Following are examples of product labels with explanations of the colors used.

Danger Label

White lettering on a black background except the word **DANGER** which is white with a red background.



Caution Label

White lettering on a black background except the word **CAUTION** which is black with a yellow background.

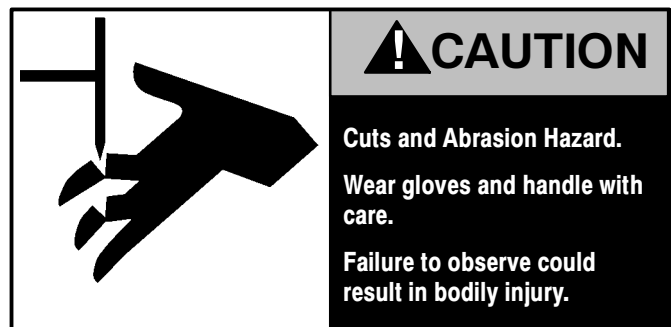

Warning Label

White lettering on a black background except the word **WARNING** which is black with an orange background.

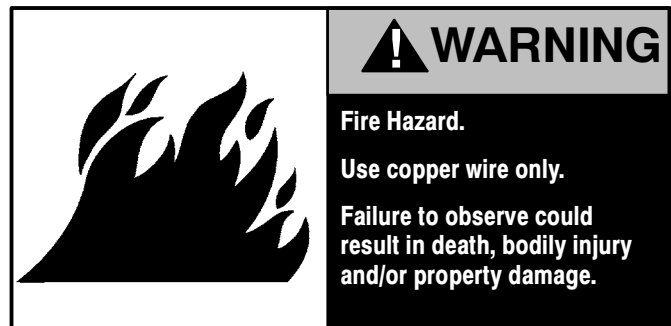

! WARNING

Read this manual and follow its instructions and adhere to all Cautions and Warnings in the manual and on the unit. Consult a qualified service technician for installation, adjustment and maintenance.

Failure to observe and follow Cautions, Warnings and instructions may result in death, bodily injury, or property damage.

Safety Rules

Your unit is built to provide many years of safe and dependable service providing it is properly installed and maintained. However, abuse and/or improper use can shorten the life of the unit and create hazards for you, the owner.

- A. The U.S. Consumer Product Safety Commission recommends that users of gas-burning appliances install carbon monoxide detectors. There can be various sources of carbon monoxide in a building or dwelling. The sources could be gas-fired clothes dryers, gas cooking stoves, water heaters, furnaces, gas-fired fireplaces, wood fireplaces, and several other items. Carbon monoxide can cause serious bodily injury and/or death. Therefore, to help alert people of potentially dangerous carbon monoxide levels, you should have carbon monoxide detectors listed by a nationally recognized agency (e.g. Underwriters Laboratories or International Approval Services) installed and maintained in the building or dwelling (see Note below).

- B. There can be numerous sources of fire or smoke in a building or dwelling. Fire or smoke can cause serious bodily injury, death, and/or property damage. Therefore, in order to alert people of potentially dangerous fire or smoke, you should have fire and smoke detectors listed by Underwriters Laboratories installed and maintained in the building or dwelling (see Note below).

Note: The manufacturer of your furnace does not test any detectors and makes no representations regarding any brand or type of detector.

- C. To ensure safe and efficient operation of your unit, you should do the the following:

1. **Thoroughly read this manual and labels on the unit.** This will help you understand how your unit operates and the hazards involved with gas and electricity.
2. **Do not use this unit if any part has been under water.** Immediately call a qualified service technician to inspect the unit and to replace any part of the control system and any gas control which has been under water.
3. **Never obstruct the vent grilles, or any ducts that provide air to the unit.** Air must be provided for proper combustion and ventilation of flue gases.
4. **Familiarize yourself with the possible air starvation signals.** These are outlined in the Combustion Air section.
5. **Check the combustion air supply.** Some models use air drawn from outside, **See Figure 2.** Other models and other appliances use combustion air from inside the structure. Air starvation signals are given on this page. If any of the signals are noticed, perform a combustion air check as shown on page 4 or call a service technician. If you add weather stripping, storm windows, insulation, an additional fuel burning appliance, or remodel the structure, a combustion air check **MUST** be accomplished after the addition.
6. **Maintain safety and service clearances from the unit.** These are listed on Unit Rating Plate on the cabinet. Keep

the unit area clean and free of combustible materials at all times. Never store gasoline, paint, aerosol cans, waxes, bleaches, dry cleaning fluid or items such as paper or, rags near the unit.

7. **Familiarize yourself with all controls.** Make sure you know how to shut off the gas and the electrical power to the unit. If the unit is to be shut down for an extended length of time (example; remodeling project), turn off both the gas and the electrical power. For safety, always turn them off before performing service or maintenance on the unit.
8. **Establish a regular service and maintenance schedule.** This will ensure efficient and safe operation of the unit. It is recommended that you have a qualified service agency perform a complete check on the unit before each heating season. See unit Maintenance "Service Technician Checks".

Combustion Air (Your Safety)**! WARNING**

All fuel-burning appliances must be provided with enough fresh air for proper combustion and ventilation of flue gases.

Some models use air from the space in which they are located, and other appliances in the same space may also be using indoor air for ventilation and/or combustion.

Lack of combustion air will result in carbon monoxide gas which could cause death or serious bodily injury.

New materials and methods are being used in construction and remodeling which result in lower energy costs for heating and cooling. It may also mean your appliances may not be getting enough air for combustion and ventilation of flue gases. The use of exhaust fans, fireplaces, clothes dryers, and other appliances consume air or vent it outside.

If the appliances or heating unit can't get enough air, two conditions may result:

1. The appliance or heating unit may produce carbon monoxide gas.
Carbon monoxide or "CO" is a colorless and odorless gas produced when fuel is not burned completely or when the flame does not receive sufficient oxygen.
2. The appliance may not vent flue gases properly.

The following are signs that your appliances may not be getting enough air for proper combustion.

Be aware of these signals;

1. **Headaches-Nausea-Dizziness**
2. **Excessive humidity-Heavily frosted windows or a moist "clammy" feeling in the structure .**
3. **Smoke from the fireplace won't draw up the chimney.**

! WARNING

If you experience headaches, nausea, or dizziness, carbon monoxide may be present.

Leave the house immediately and call your gas supplier.

Carbon monoxide poisoning can result in death from asphyxiation or serious bodily injury.

Combustion Air Checks

If any of the signals are noticed, perform a combustion air check or call a service technician. If you add weather stripping, storm windows, insulation, an additional fuel burning appliance, or remodel the structure, a combustion air check **MUST** be accomplished after the addition.

Make the inspection as follows:

1. Close all doors and windows. If you have a fireplace, start a fire and wait until flames are burning vigorously.
2. Turn on all exhausting devices, such as: kitchen and bathroom exhaust fans and dryers (gas or electric).
3. Turn on all vented gas appliances, such as: heating equipment (includes any room heaters) and water heaters.
4. Wait ten (10) minutes for drafts to stabilize.
5. On appliances with a draft hood, check for spillage by holding a lighted match 2 inches from the draft hood opening. Reference **Figure 1** which shows a water heater draft hood.

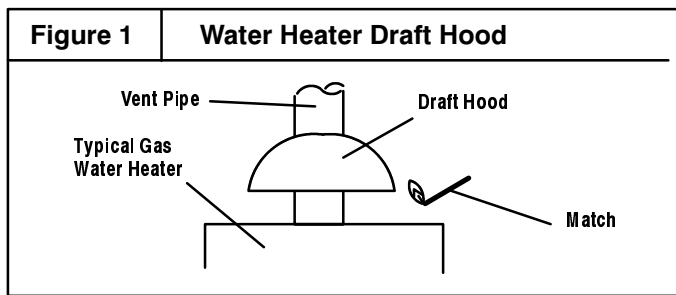

- A. *Match flame pulls toward draft hood.* This indicates no spillage and that appliance is getting enough air for combustion. Return exhausting devices and appliances to the condition you found them.
- B. *Match goes out or flame wavers away from draft hood.* This indicates spillage and that appliance is not getting enough air for combustion.

⚠ WARNING

Draft hood spillage means there is not enough air for proper combustion and carbon monoxide may be present.

Keep a window open (a minimum of 2 inches) near the appliance until a permanent air duct is installed. Contact a qualified service agency.

Carbon monoxide poisoning can result in death from asphyxiation or serious bodily injury.

If draft hood spillage is indicated:

1. Check for plugged flue connectors and chimneys. Check and repair stoppage and test again.
2. If you have a fireplace, open a window or door near the fireplace and then check for spillage. If spillage stops, do not use the fireplace until you can supply fresh air by a permanent duct.
3. If you have kitchen and bathroom exhaust fans, turn them **OFF** and check for spillage. If spillage stops, do not use exhaust fans until you can supply fresh air by a permanent duct. Circuit breakers for fans should be turned off.
4. Spillage means air starvation and a fresh air duct or air intakes must be installed to provide air directly to the area

around the unit. These **MUST** comply with local and state building codes or in their absence with the National Fuel Gas Code NFPA 54 ANSI Z223.1, Current edition or in Canada the National Standard CAN/CGA 1-B149.

Indoor Humidity (Your Comfort)

Relative humidity is important to your health. Proper humidification helps cut down incidences of respiratory illness. Air that is too wet may damage the building structure. Air that is too dry is uncomfortable. A quick way to test for proper humidity is as follows:

1. Look for frequent fogging or excessive condensation on the inside of windows. This indicates the indoor humidity level is too high for outdoor weather conditions.
2. Drop three ice cubes into a glass of water and stir. If, within three minutes, moisture does not form on the glass, the air is too dry and a humidifier would be beneficial. (Do not perform this test in the kitchen, cooking vapors may produce inaccurate results.)

A good relative humidity is one just high enough to barely start condensation along the lower edges or lower corners of the windows, when it is cold outside. More than that can be damaging.

If the humidity is too high, try these suggestions to lower the humidity:

1. Reduce setting or discontinue use of humidifier.
2. Use range and bathroom exhaust fans while cooking and bathing. Open a door or window for a few minutes to bring in cool drier air.
3. Cook with pans covered.
4. Take shorter baths or showers with cooler water.
5. Install a fresh air intake duct. Cold, dry air brought in from outside to the unit area lowers the indoor humidity level.
6. Have appliances checked. A malfunctioning appliance can contribute water vapor to the structure.
7. If the problem continues, consult a heating contractor about adding a heat recovery ventilator or air to air heat exchanger.

About Your Unit

Figure 2 or **Figure 3** shows the location of the components in the unit.

Circulating Air Blower

The blower circulates room air through the unit, air ducts, and into the rooms of the structure. The blower can be set at the thermostat for automatic or manual operation. In manual mode the blower operates continuously. In automatic, the blower does not come on until a preset time after the gas valve is energized. When the structure reaches the temperature set on the thermostat, the unit will shut off. The blower will continue to run until the unit cools down.

Thermostat

There are many types and styles of thermostats. Most thermostats control both heating and cooling functions and have a Fan Switch with **AUTO** and **ON** settings. On **AUTO**, the Circulating Air Blower will cycle on/off with the unit. Blower speed (High or Low) will correspond to the mode of operation of the unit. If the Fan Switch is positioned to **ON** the blower will run continuously.

In addition some thermostats are programmable with multiple set backs. The set backs can be pre-programmed to lower or raise the temperature automatically.

Be sure to become familiar with your thermostat.

Rating Plate

The rating plate contains important information for the service technician and lists the complete model, manufacturing and serial numbers. You should always provide all these numbers when requesting parts or if you need service. See **Figure 2** or **Figure 3** for rating plate location.

Door Interlock Switch

All the electrical power for the unit goes through the door interlock switch. The interlock switch interrupts electrical power to the unit when the blower door is removed. The unit will not operate until the blower door is reinstalled.

Fan Control

The fan/delay control provides power to the circulating air blower to keep it on until the unit cools down.

The fan off setting can be adjusted if the fan remains on long enough that cool drafts are felt in the room after the furnace shuts off.

The delay is set by moving a set of switches on the control. The Fan Control has a printed diagram on it showing the various delay combinations. Refer to **Figure 2** or **Figure 3** for location of the control.

If you are unsure how to set the Fan Control, contact a Qualified Service Technician.

Electronic Ignition Module/Gas Valve

When the thermostat calls for heat it completes a circuit to the electronic ignition module. The module sends an electrical signal which ignites the gas as the gas valve opens to let gas flow to the main burners.

When the flame is firmly established, a sensor detects flame and the module will discontinue the electrical signal. For safety it will automatically restart if the flame is interrupted. If there is a malfunction, the gas valve automatically shuts off the gas.

Pressure Switch

The unit is equipped with a pressure switch to shut down the unit under various flue conditions. The switch is connected to the vent by factory supplied tubing.

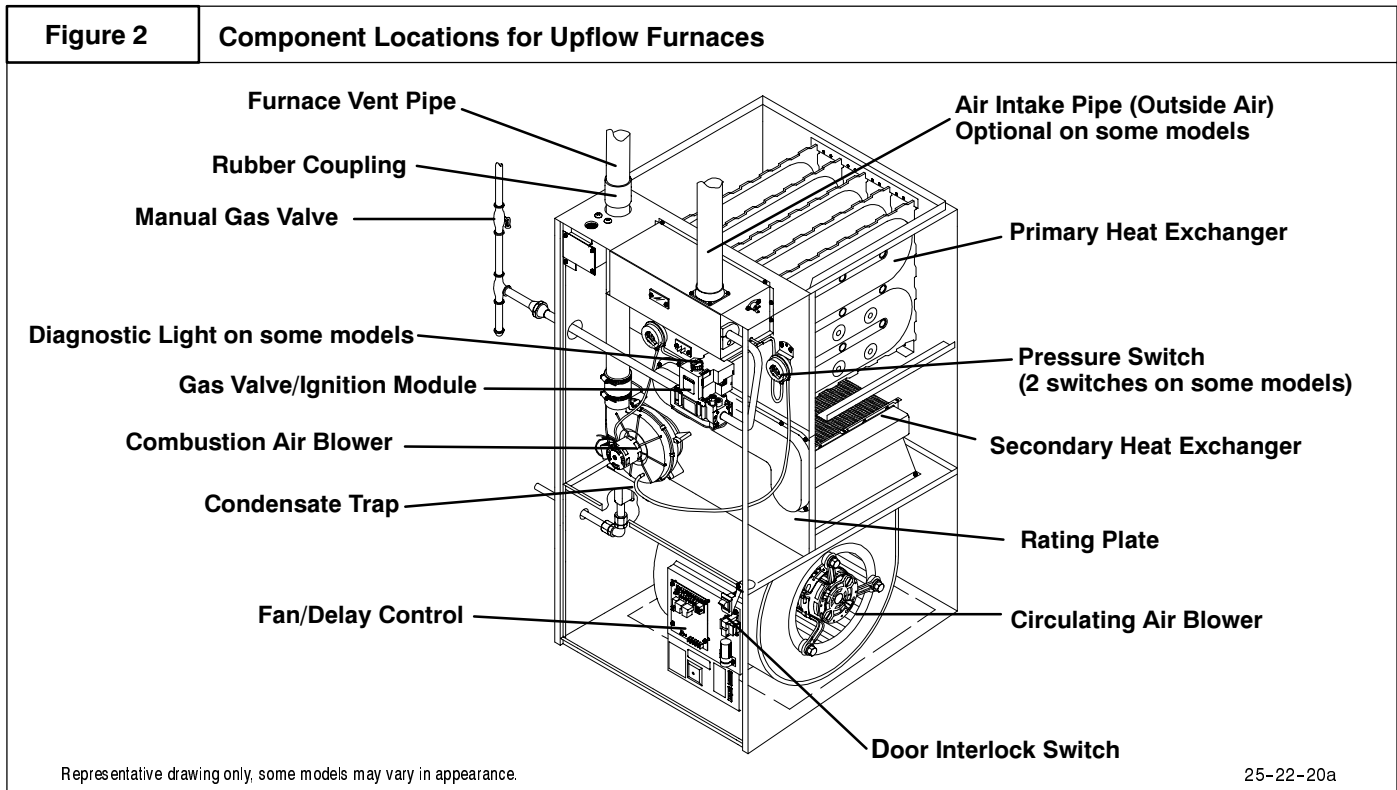

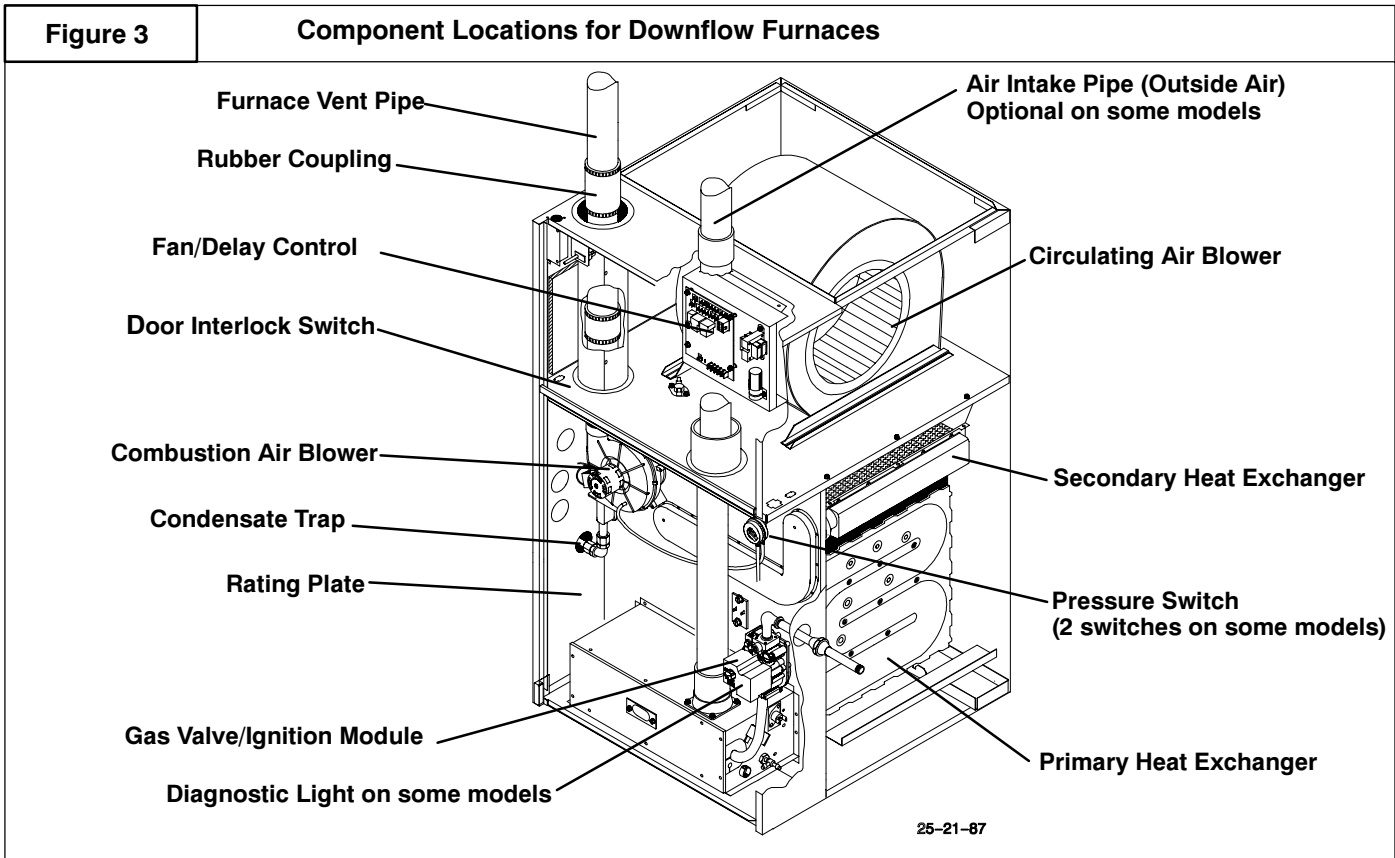

Operating Your Unit

Keep the blower access door and all access panels in place except for inspection or maintenance.

Before starting your unit be sure you read and understand all of the procedures in this manual. Check to make sure the unit filter is clean and correctly installed.

Starting The Unit

See **Figure 4** for an illustration of the gas valve.

1. Turn the thermostat to its lowest temperature setting or to **OFF** if equipped with a System Select Switch.
2. Turn **OFF** all electric power to the unit at the disconnect switch or circuit breaker.
4. Remove the louvered access panel in front of the unit by lifting the panel up and outwards. Removing the panel will expose the gas control switch.
5. Slide the gas control switch to **OFF**. See **Figure 4**.
6. Wait five (5) minutes to clear out any gas. If you then smell gas, **STOP!** Follow the safety information on the cover of this manual. If you do not smell gas, go to the next step.
7. Slide the control switch to **ON**.
8. Reinstall all access panels.
9. Turn **ON** all electrical power to the unit.

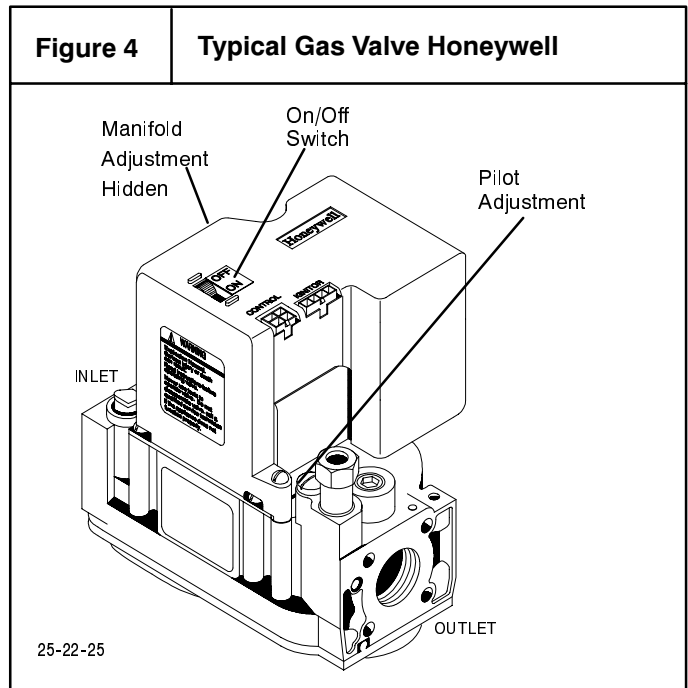

10. Set the thermostat to the desired temperature and the System Select Switch to **HEAT**.

The unit will activate an ignitor which lights the pilot flame. When the pilot lights and verifies a steady flame, the ignition system brings on the main burners.

System Retries

The ignition system tries to relight the burners whenever the built-in flame sensor detects no flame.

Turning Off The unit

Set the thermostat to the lowest setting or set System Select Switch to **OFF** if equipped.

Should overheating occur or the gas supply fail to shut off, shut off the manual gas valve to the unit before shutting off the electrical supply.

Extended Shutdown

1. Set thermostat to lowest setting or set System Select Switch to **OFF** if equipped.
2. Slide the gas valve control switch to **OFF**.
3. Turn Manual Shutoff Valve to **OFF** position, (at right angle or 90° to gas line).
4. Turn electric power off. (May be left **ON** for set-back type thermostat with batteries, provided thermostat has a system select switch to place in the **OFF** position.)

L P Model Units

If your L.P. (liquefied petroleum) gas unit is installed in an excavated or low lying area, we recommend that you contact your L.P. supplier about installing a warning device that would alert you of a gas leak.

! WARNING

Fire or explosion hazard.

L.P. gas is heavier than air. Leaking gas can settle in low areas such as a crawl space. If you suspect the presence of gas, follow the instructions on the cover of this manual.

Failure to observe could result in death, bodily injury or property damage.

Freezing Temperatures And Your Structure

! WARNING

Freeze warning.

Turn off water system.

If your unit remains shut off during cold weather the water pipes could freeze and burst, resulting in serious water damage.

Your unit is equipped with safety devices that may keep it from operating if sensors detect abnormal conditions such as clogged exhaust flues.

If your unit remains shut off during cold weather the water pipes could freeze and burst, resulting in serious water damage.

If the structure will be unattended during cold weather you should take these precautions.

1. Turn off main supply water into the structure and drain the water lines if possible. Open faucets in appropriate areas.
2. Have someone check the structure frequently during cold weather to make sure it is warm enough to prevent pipes from freezing. Suggest they call qualified service agency, if required.

Winter Shutdown

If you go away during the winter months and do not leave the heat on in your home, the furnace blower and condensate trap need to be protected from freeze damage.

1. Disconnect the rubber coupling on top of the furnace for the vent pipe. Pour 8 ounces of sanitary type (RV) antifreeze into the vent pipe connection on the furnace to protect the combustion blower and drain trap. Reconnect the vent pipe with the coupling. When you return home your furnace can be started, as it is not necessary to drain the antifreeze. **See Figure 2 or Figure 3.**

Unit Maintenance

Have your unit inspected and serviced on an annual basis (before the heating season) by a qualified service technician.

Labeling

CAUTION

Label all wires prior to disconnection when servicing controls. Wiring errors can cause improper and dangerous operation.

Verify proper operation after servicing.

Pressure Switches

During regular yearly maintenance check for cracks in any tubes on the pressure switches.

! WARNING

Electrical shock hazard.

Turn off electric power to unit before performing any maintenance or removing panels or doors.

Failure to observe could result in death or bodily injury.

Air Filters/ Monthly

The air filter(s) should be inspected at least monthly and cleaned or replaced as required. There are two types of filters that are commonly used. The most widely used is the Fiberglass disposable type which should be **REPLACED** before it becomes clogged. The other type is the washable type constructed of aluminum mesh, foam, or reinforced fibers. Washable filters may be cleaned by soaking in mild detergent and rinsing with water.

Remember that dirty filters are the most common cause of inadequate heating or cooling performance.

Replacement Filters

Table1 lists recommended sizes and types of filters that may be used with your unit, based on the input rating and Btuh.

Replacement filters should be of the same type and size as the originals, to ensure adequate air flow and filtering. A disposable low velocity filter can be replaced with a washable high velocity type. *Do not replace a high velocity filter with a disposable low velocity filter.*

Filter Replacement - Upflow

Some models come with a filter rack and filter. The filter rack may be installed in the bottom of the blower compartment, or on the outside on either side of the unit. A plastic endcap is inserted in the

filter rack after the filter is installed. The endcap keeps air from escaping around the open end of the filter rack. See **Figure 5** and **Figure 6** for locations.

Filter racks attached to the unit are made so the filter simply slides out one side for removal.

1. Turn off electric power to furnace.
2. Remove the endcap from the filter rack.
3. Slide the filter out of the filter rack.
4. Inspect the filter(s) and replace or clean washable types. If filter is aluminum mesh it should be recoated with filter coating spray.
5. Reinstall the endcap in the filter rack.
6. Turn furnace on.

! WARNING

Fire hazard from dust and lint buildup on internal unit parts.

Never operate unit without a filter installed.

Failure to observe could result in death or bodily injury.

Filter Replacement - Bottom Mounted

1. Turn off power to furnace.
2. Remove blower door.
3. Slide filter straight out toward you.
4. Inspect the filter(s) and replace or clean washable types. If filter is aluminum mesh it should be recoated with filter coating spray.
5. Replace blower door.
6. Turn on electric power to furnace.

NOTE

Some filters are marked with an arrow to indicate the proper direction of air flow through the filter. The air flow direction will be towards the blower motor. Make sure filter is installed correctly.

Figure 6 Bottom Mounted Filter Rack

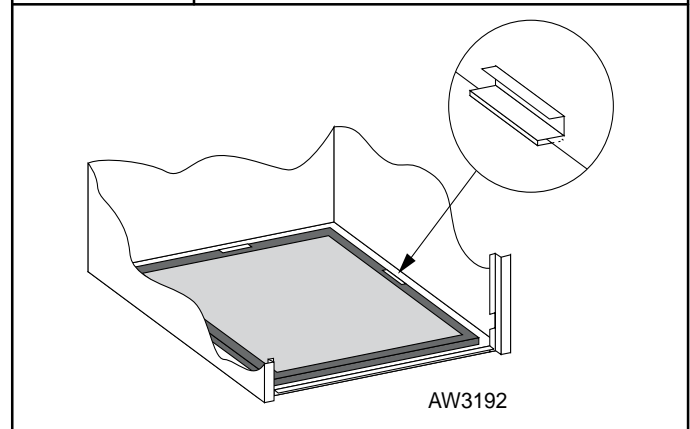

Filter Replacement - Counterflow

These units come with a filter rack and filters. The filter rack is installed in the top of the unit from the right side. To remove filter, refer to **Figure 7** for the following steps.

1. Turn off power to furnace.
2. Remove compartment door.
3. Reach up above right side of blower and lift dirty filters out of rack at top of furnace.
4. Straighten up filters and pull straight down at side of blower. Pull out through right side of door opening.
5. Inspect the filter(s) and replace or clean washable types. If filter is aluminum mesh it should be recoated with filter coating spray.
6. Reinstall the filter in the filter rack.
7. Reinstall compartment door.
8. Turn on electric power to furnace.

Some filters are marked with an arrow to indicate the proper direction of air flow through the filter. The air flow direction will be towards the blower motor. Make sure filter is installed correctly.

Figure 5 Side Mounted Filter Rack

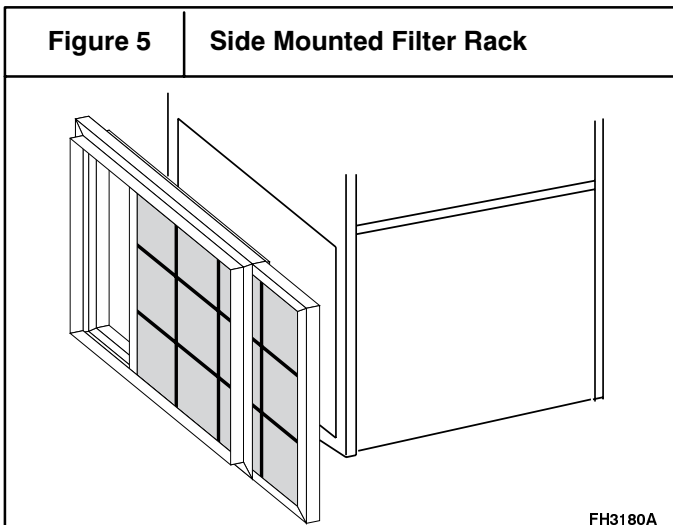

Figure 7 Counterflow Filter Replacement

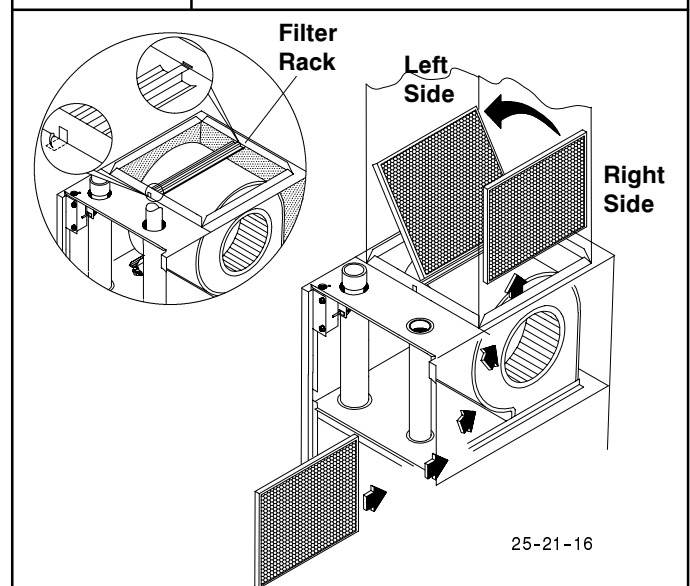

Table1	Recommended Filter Sizes		
Unit Size Heating Input 1000 x Btuh	Nominal Air Flow Cubic Feet per Minute (CFM)	Recommended Filter Sizes Sq. In. Surface Area/Nominal Size (inches)	
		Disposable Filters	Cleanable Filters
40 - 50	800-900	500 or 20 x 25	350 or 14 x 25
40 - 50, 75, and 100	900-1100	600 or 20 x 30	350 or 14 x 25
40 - 50, 75, and 100	1100-1300	350 or 14 x 25 (2Req.)	350 or 14 x 25
75,100, and 125	1300-1500	400 or 16 x 25 (2Req.)	400 or 16 x 25 (2Req.)
100 and 125	1500-1700	500 or 20 x 25 (2 Req.)	500 or 20 x 25
125	1900-2100	600 or 20 x 30 (2 Req.)	500 or 20 x 25

NOTE: Some downflow models use 2 16" X 18" cleanable filters.

Main Burner Flame/Monthly

To inspect the Pilot and Main Burner flame it will be necessary to remove the louvered panel on the front of the unit.

Check for the following through the view port:

- Stable and blue flames
- Flames extending directly from burner into heat exchanger.
- Flames do **NOT** touch sides of heat exchanger.

NOTE: Dust may cause orange tips or wisps of yellow, but flames **MUST NOT** have solid, yellow tips.

- Check main burner flames monthly.

Pilot Flame

While the main burner is **ON**, the flame should envelop the upper part of the Flame Sensor, as shown in **Figure 8**.

Contact a qualified service agency at once if an abnormal flame appearance is identified.

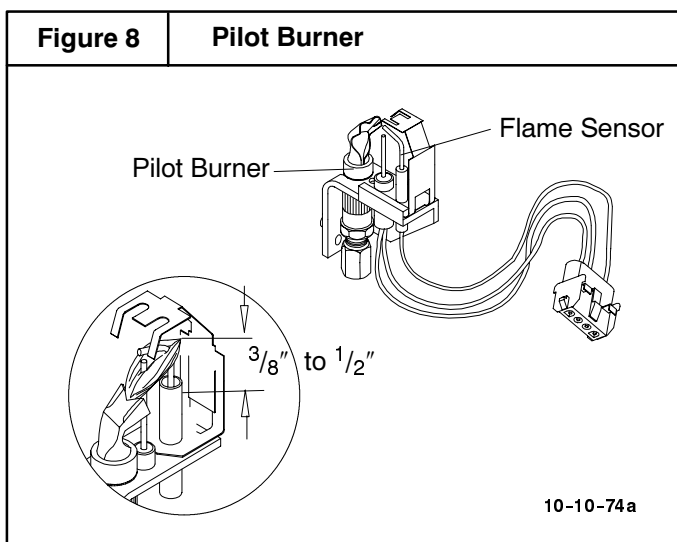

Monthly Inspection

A properly adjusted gas unit should not require cleaning at frequent intervals, but it should be inspected regularly to ensure safe and efficient operation. A brief monthly inspection is recommended that does not require disassembly. In addition you should

have the unit inspected, and cleaned if required, by a qualified service technician annually.

1. Check the vents to be sure they are clear and free of obstructions.
2. Check return air duct to make sure it is sealed to unit casing and that it is in good physical condition.
3. Inspect the unit base. It must be in good physical condition.
4. Inspect the drain line and overflow line monthly. If a condensate neutralizer cartridge is used and becomes plugged, the condensate will flow through the overflow line. If this happens, clean both cartridge and drain lines. To clean, disconnect and unscrew end cap from cartridge. Pour the neutralizer out and flush neutralizer and inside of cartridge with water. Pour neutralizer back, adding neutralizer if cartridge is less than 3/4 full.
5. Remove the front panel and use a flashlight to inspect the visible part of the burners and igniter. Check for loose soot and give particular attention to obvious deterioration from corrosion or other sources. If soot or deterioration is found inside the unit **DO NOT OPERATE UNIT**; call a qualified service technician.

Lubrication

The blower motor and the combustion air blower are prelubricated by the manufacturer and **DO NOT** require oiling.

Service Technician Checks

When the unit is being inspected for condition and operation have the Service Technician check the following items.

1. Check all flue gas passages including main and pilot burners, heat exchanger, and vent .
2. Check gas pipe and all connections inside and leading to the unit for leaks.
3. Check electrical wiring and connections.
4. Check supply and return air ducts for leakage, blockage and connections to unit.
5. Check circulating air blower wheel and motor. Clean them if required.
6. Perform an operational checkout on the unit to be sure safety controls function and that unit operates properly.

For additional information, the Service Technician can consult the installation instructions for the unit.