

TECHNICAL SUPPORT MANUAL

Split System Heat Pump

N4H3

Safety Labeling and Signal Words

DANGER, WARNING, CAUTION, and NOTE

The signal words **DANGER**, **WARNING**, **CAUTION**, and **NOTE** are used to identify levels of hazard seriousness. The signal word **DANGER** is only used on product labels to signify an immediate hazard. The signal words **WARNING**, **CAUTION**, and **NOTE** will be used on product labels and throughout this manual and other manuals that may apply to the product.

DANGER – Immediate hazards which **will** result in severe personal injury or death.

WARNING – Hazards or unsafe practices which **could** result in severe personal injury or death.

CAUTION – Hazards or unsafe practices which **may** result in minor personal injury or product or property damage.

NOTE – Used to highlight suggestions which **will** result in enhanced installation, reliability, or operation.

Signal Words in Manuals

The signal word **WARNING** is used throughout this manual in the following manner:



The signal word **CAUTION** is used throughout this manual in the following manner:



Signal Words on Product Labeling

Signal words are used in combination with colors and/or pictures on product labels.

TABLE OF CONTENTS

Wiring Diagrams	2 – 3
Charging Chart	4
Tech Labels (Expanded Data) – Cooling	5 – 11
Tech Labels (Expanded Data) – Heating	12 – 18
Cooling Multiplying Factors	19 – 24
Heating Multiplying Factors	25 – 30
Condenser Only Data	15 – 18
Exploded Drawings	31 – 33
Parts List	34 – 36
Model Number Identification	37 – 38



DEATH, PERSONAL INJURY, AND/OR PROPERTY DAMAGE HAZARD

Failure to carefully read and follow this warning could result in equipment malfunction, property damage, personal injury and/or death.

Installation or repairs made by unqualified persons could result in equipment malfunction, property damage, personal injury and/or death.

The information contained in this manual is intended for use by a qualified service technician familiar with safety procedures and equipped with the proper tools and test instruments.

Installation must conform with local building codes and with the National Electrical Code NFPA70 current edition or Canadian Electrical Code Part 1 CSA C.22.1.

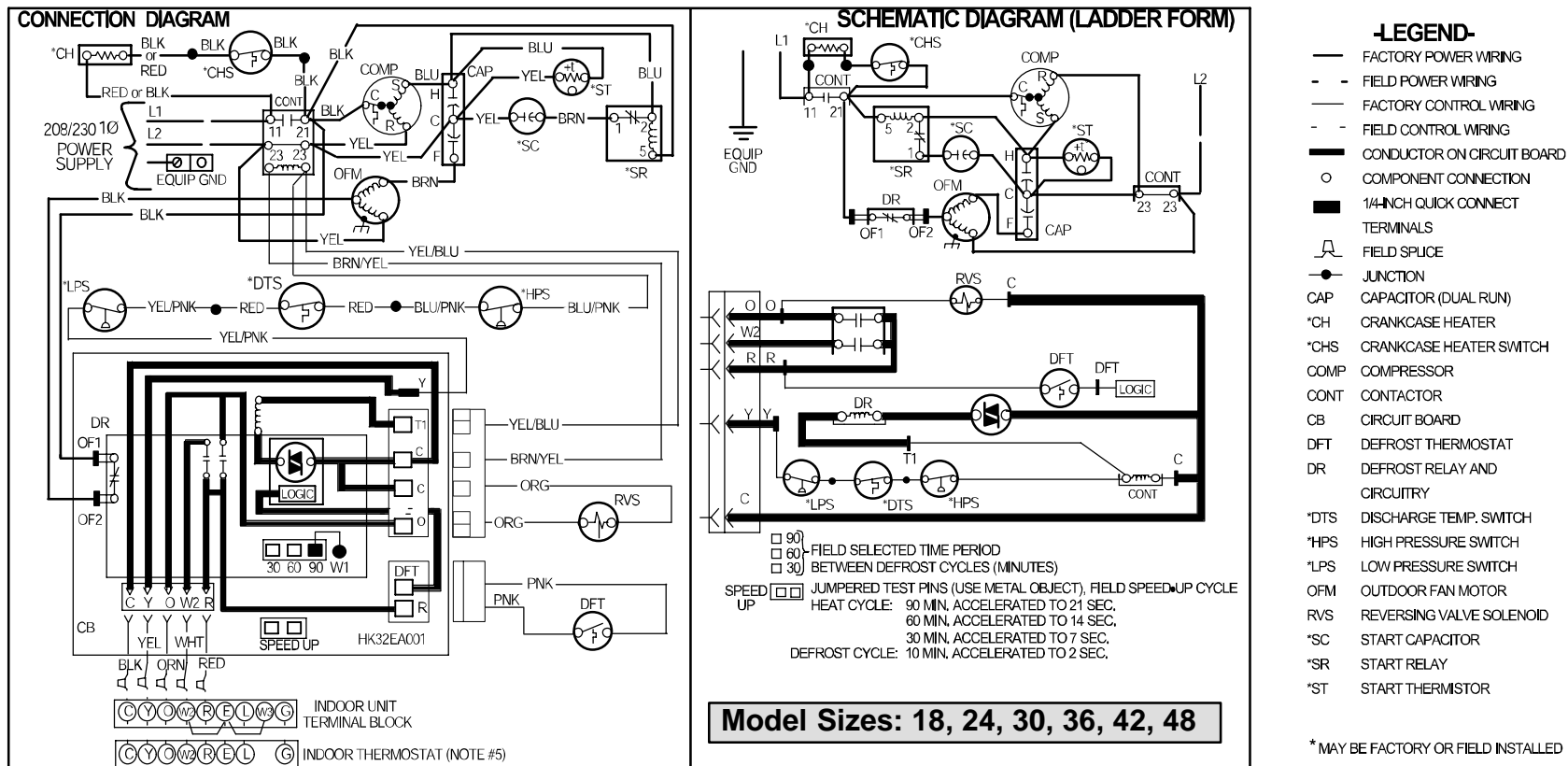

1. Symbols are electrical representation only.
2. Compressor and fan motor furnished with inherent thermal protection.
3. To be wired in accordance with National Electric N.E.C. and local codes.
4. N.E.C. class 2, 24 V circuit, min. 40 VA required, 60 VA on units installed with LLS.
5. Connection for typical heat pump thermostat. For other arrangements see installation instructions.
6. Use copper conductors only. Use conductors suitable for at least 75°C (167°F).
7. If indoor section has a transformer with a grounded secondary, connect the grounded side to "C" on the circuit board.
8. When start capacitor and relay are installed, start thermistor (PTC) is not used.
9. CH not used on all units.
10. If any of the original wire, as supplied, must be replaced, use the same or equivalent wire.
11. Check all electrical connections inside control box for tightness.
12. Do not attempt to operate unit until service valves have been opened.
13. Do not rapid cycle compressor. Compressor must be off 3 minutes to allow pressures to equalize between high and low side before starting.

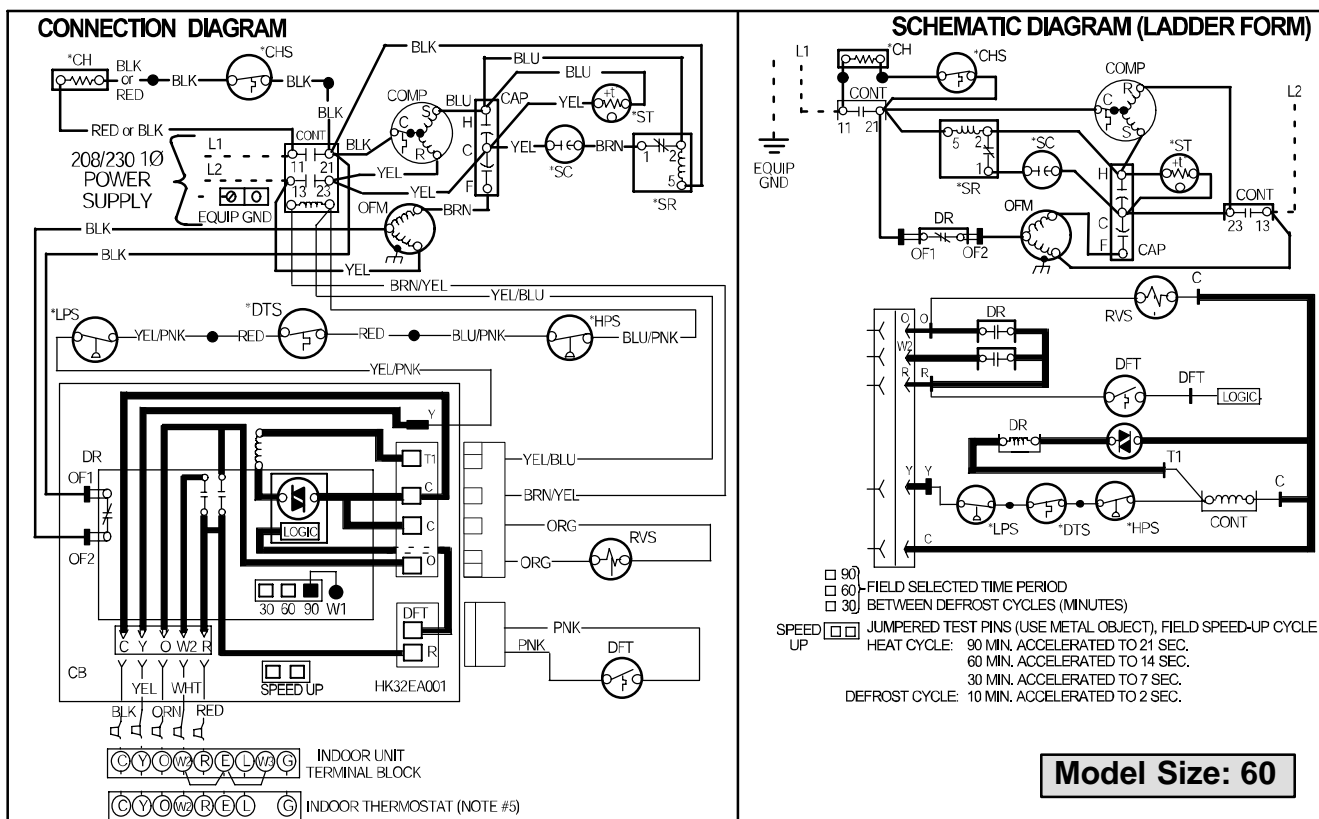

* MAY BE FACTORY OR FIELD INSTALLED

1. Symbols are electrical representation only.
2. Compressor and fan motor furnished with inherent thermal protection.
3. To be wired in accordance with National Electric N.E.C. and local codes.
4. N.E.C. class 2, 24 V circuit, min. 40 VA required, 60 VA on units installed with LLS.
5. Connection for typical heat pump thermostat. For other arrangements see installation instructions.
6. Use copper conductors only. Use conductors suitable for at least 75°C (167°F).
7. If indoor section has a transformer with a grounded secondary, connect the grounded side to "C" on the circuit board.
8. When start capacitor and relay are installed, start thermistor (PTC) is not used.
9. CH not used on all units.
10. If any of the original wire, as supplied, must be replaced, use the same or equivalent wire.
11. Check all electrical connections inside control box for tightness.
12. Do not attempt to operate unit until service valves have been opened.
13. Do not rapid cycle compressor. Compressor must be off 3 minutes to allow pressures to equalize between high and low side before starting.

R-410A CHARGING CHART

- Find the required Subcooling Temperature on the unit Rating Plate. Use the closest column on the chart below (6, 8, 10, 12, 14 or 16) .
- Add or remove refrigerant until both the Liquid Line Temperature and Liquid Pressure agree with chart data.

Measured Liquid Pressure (psig)	Rating Plate (required) Subcooling Temperature (° F)					
	6	8	10	12	14	16
	Required Liquid Line Temperature (° F)					
189	60	58	56	54	52	50
195	62	60	58	56	54	52
202	64	62	60	58	56	54
208	66	64	62	60	58	56
215	68	66	64	62	60	58
222	70	68	66	64	62	60
229	72	70	68	66	64	62
236	74	72	70	68	66	64
243	76	74	72	70	68	66
251	78	76	74	72	70	68
259	80	78	76	74	72	70
266	82	80	78	76	74	72
274	84	82	80	78	76	74
283	86	84	82	80	78	76
291	88	86	84	82	80	78
299	90	88	86	84	82	80
308	92	90	88	86	84	82
317	94	92	90	88	86	84
326	96	94	92	90	88	86
335	98	96	94	92	90	88
345	100	98	96	94	92	90
354	102	100	98	96	94	92
364	104	102	100	98	96	94
374	106	104	102	100	98	96
384	108	106	104	102	100	98
395	110	108	106	104	102	100
406	112	110	108	106	104	102
416	114	112	110	108	106	104
427	116	114	112	110	108	106
439	118	116	114	112	110	108
450	120	118	116	114	112	110
462	122	120	118	116	114	112
474	124	122	120	118	116	114
486	126	124	122	120	118	116
499	128	126	124	122	120	118
511	130	128	126	124	122	120

N4H318AKA N4H318GKA		N4H318*KA Outdoor With FS(M,U)4X18**** Indoor Cooling																								
		Outdoor Ambient Temperature – °F, Dry Bulb																								
		75					85					95					105					115				
		Entering Indoor Temperature – °F, Wet Bulb																								
CFM		72	67	63††	62	57	72	67	63††	62	57	72	67	63††	62	57	72	67	63††	62	57	72	67	63††	62	57
525	MBh †	20.63	18.78	17.40	17.05	16.48	19.61	17.82	16.51	16.18	15.79	18.54	16.83	15.58	15.29	15.07	17.46	15.82	14.63	14.39	14.32	16.45	14.88	13.74	13.61	13.61
	S/T ‡	0.51	0.70	0.73	0.91	1.00	0.52	0.71	0.74	0.94	1.00	0.52	0.73	0.76	0.96	1.00	0.53	0.75	0.78	0.99	1.00	0.54	0.77	0.80	1.00	1.00
	AMPS^	5.34	5.42	5.49	5.50	5.52	6.03	6.11	6.17	6.18	6.19	6.78	6.86	6.92	6.93	6.94	7.63	7.71	7.78	7.79	7.79	8.48	8.57	8.63	8.64	8.64
	HI PR	269	266	265	264	263	311	308	306	305	305	356	353	351	351	350	407	404	402	402	401	457	454	452	452	452
	LO PR	155	142	132	130	126	157	144	134	132	129	160	146	137	135	133	162	149	139	137	137	164	151	141	140	140
600	MBh †	21.01	19.12	17.74	17.42	17.14	19.93	18.12	16.80	16.53	16.40	18.83	17.10	15.84	15.64	15.64	17.70	16.05	14.86	14.84	14.84	16.66	15.08	13.93	14.09	14.09
	S/T ‡	0.52	0.73	0.75	0.96	1.00	0.53	0.74	0.77	0.98	1.00	0.54	0.76	0.79	1.00	1.00	0.55	0.79	0.81	1.00	1.00	0.56	0.81	0.84	1.00	1.00
	AMPS^	5.45	5.53	5.60	5.61	5.62	6.14	6.22	6.28	6.29	6.29	6.89	6.97	7.04	7.04	7.04	7.74	7.82	7.89	7.88	7.88	8.59	8.68	8.75	8.73	8.73
	HI PR	269	267	265	265	264	312	309	307	306	306	357	354	352	352	352	408	405	402	402	402	457	455	453	453	453
	LO PR	158	145	135	133	131	160	147	137	136	135	163	149	139	138	138	165	152	142	142	142	167	154	144	145	145
675	MBh †	21.28	19.38	17.99	17.74	17.69	20.17	18.34	17.02	16.91	16.91	19.03	17.29	16.03	16.10	16.10	17.88	16.22	15.02	15.27	15.27	16.80	15.22	14.07	14.48	14.48
	S/T ‡	0.54	0.76	0.78	0.99	1.00	0.55	0.78	0.80	1.00	1.00	0.56	0.80	0.83	1.00	1.00	0.57	0.82	0.85	1.00	1.00	0.59	0.85	0.88	1.00	1.00
	AMPS^	5.56	5.65	5.71	5.72	5.72	6.25	6.33	6.39	6.39	6.39	7.01	7.09	7.15	7.14	7.14	7.85	7.94	8.01	7.99	7.99	8.70	8.79	8.86	8.83	8.83
	HI PR	270	267	266	265	265	312	309	307	307	307	358	355	352	353	353	408	405	403	403	403	458	455	453	454	454
	LO PR	161	148	138	136	136	163	150	140	139	139	165	152	142	143	143	167	154	144	146	146	169	156	146	150	150

† Total capacities are net (I.D. blower heat subtracted) system capacities based on 25' line set.

If additional tubing length and/or indoor unit is located above outdoor unit, a slight variation in capacity may occur.

†† At TVA rating indoor condition (75 °F db, 63 °F wb), all other indoor air temperatures are at 80 °F db

If additional tubing length and/or indoor unit is located above outdoor unit, a slight variation in capacity may occur.

^ System amps are total of indoor and outdoor amps.

‡ Chart data is for 80° F indoor dry bulb. For indoor db temperatures other than 80° F, measure Indoor db and Indoor CFM, and plug these into the formula below. Measure outdoor db and indoor wet bulb, apply these to the chart above, find MBh and S/T, and plug these into the formula below. (Note: if indoor db is the only thing changing, total capacity, MBh, stays the same.)

$$\text{Sensible Capacity at Indoor db LOWER than } 80^\circ \text{ F} = (\text{MBh} \times \text{S/T}) - \left(\frac{(80 - \text{Indoor db}) \times 835 \times \text{Indoor CFM}}{1000} \right)$$

$$\text{Sensible Capacity at Indoor db HIGHER than } 80^\circ \text{ F} = (\text{MBh} \times \text{S/T}) + \left(\frac{(\text{Indoor db} - 80) \times 835 \times \text{Indoor CFM}}{1000} \right)$$

N4H324AKA N4H324GKA		N4H324*KA Outdoor With FS(M,U)4X24**** Indoor Cooling																								
		Outdoor Ambient Temperature – °F, Dry Bulb																								
		75					85					95					105					115				
		Entering Indoor Temperature – °F, Wet Bulb																								
CFM		72	67	63††	62	57	72	67	63††	62	57	72	67	63††	62	57	72	67	63††	62	57	72	67	63††	62	57
700	MBh †	26.97	24.65	22.94	22.50	21.73	25.72	23.49	21.84	21.42	20.87	24.41	22.26	20.68	20.30	19.96	23.03	20.97	19.46	19.14	19.00	21.54	19.59	18.16	17.96	17.96
	S/T ‡	0.51	0.70	0.72	0.91	1.00	0.52	0.71	0.74	0.93	1.00	0.52	0.72	0.75	0.95	1.00	0.53	0.74	0.77	0.98	1.00	0.54	0.77	0.79	1.00	1.00
	AMPS^	7.21	7.21	7.22	7.21	7.22	8.09	8.10	8.10	8.10	8.11	9.07	9.08	9.09	9.09	9.09	10.16	10.17	10.18	10.18	10.18	11.36	11.37	11.39	11.39	11.39
	HI PR	281	278	275	275	274	324	320	318	317	316	371	367	365	364	363	422	418	416	415	415	479	475	473	472	473
	LO PR	154	141	131	129	125	156	143	133	131	128	158	145	135	133	131	161	148	138	136	135	164	150	140	139	139
800	MBh †	27.42	25.09	23.37	22.96	22.57	26.13	23.88	22.22	21.86	21.66	24.76	22.60	21.02	20.72	20.70	24.27	21.27	19.76	19.67	19.67	21.80	19.84	18.41	18.57	18.57
	S/T ‡	0.53	0.73	0.75	0.95	1.00	0.53	0.74	0.77	0.97	1.00	0.54	0.76	0.79	1.00	1.00	0.55	0.78	0.81	1.00	1.00	0.57	0.81	0.83	1.00	1.00
	AMPS^	7.36	7.36	7.37	7.37	7.37	8.25	8.25	8.26	8.26	8.26	9.22	9.23	9.24	9.24	9.24	8.95	10.32	10.34	10.33	10.33	11.50	11.52	11.53	11.54	11.54
	HI PR	282	279	276	276	275	325	321	319	318	318	371	368	365	365	365	357	419	417	417	417	479	476	473	474	474
	LO PR	157	144	134	132	130	159	146	136	134	133	162	148	138	137	137	162	150	140	140	140	166	153	143	144	144
900	MBh †	27.75	25.40	23.68	23.36	23.27	26.42	24.16	22.50	22.32	22.31	26.10	22.85	21.26	21.30	21.30	24.55	21.48	19.97	20.23	20.23	22.87	20.02	18.59	19.07	19.07
	S/T ‡	0.54	0.76	0.78	0.99	1.00	0.55	0.77	0.80	1.00	1.00	0.55	0.79	0.82	1.00	1.00	0.56	0.82	0.84	1.00	1.00	0.58	0.85	0.87	1.00	1.00
	AMPS^	7.52	7.52	7.52	7.52	7.52	8.40	8.40	8.41	8.41	8.41	8.08	9.39	9.39	9.39	9.39	9.11	10.47	10.49	10.48	10.48	10.26	11.68	11.69	11.68	11.68
	HI PR	282	279	277	276	276	325	322	319	319	319	308	369	366	366	366	358	420	417	418	418	413	476	474	475	475
	LO PR	160	147	137	135	135	162	149	139	138	138	163	151	140	141	141	165	153	142	145	145	167	155	145	149	149

† Total capacities are net (I.D. blower heat subtracted) system capacities based on 25' line set.

If additional tubing length and/or indoor unit is located above outdoor unit, a slight variation in capacity may occur.

†† At TVA rating indoor condition (75 °F db, 63 °F wb), all other indoor air temperatures are at 80 °F db

If additional tubing length and/or indoor unit is located above outdoor unit, a slight variation in capacity may occur.

^ System amps are total of indoor and outdoor amps.

‡ Chart data is for 80° F indoor dry bulb. For indoor db temperatures other than 80° F, measure Indoor db and Indoor CFM, and plug these into the formula below. Measure outdoor db and indoor wet bulb, apply these to the chart above, find MBh and S/T, and plug these into the formula below. (Note: if indoor db is the only thing changing, total capacity, MBh, stays the same.)

$$\text{Sensible Capacity at Indoor db LOWER than } 80^\circ \text{ F} = (\text{MBh} \times \text{S/T}) - \left(\frac{(80 - \text{Indoor db}) \times 835 \times \text{Indoor CFM}}{1000} \right)$$

$$\text{Sensible Capacity at Indoor db HIGHER than } 80^\circ \text{ F} = (\text{MBh} \times \text{S/T}) + \left(\frac{(\text{Indoor db} - 80) \times 835 \times \text{Indoor CFM}}{1000} \right)$$

N4H330AKA N4H330GKA		N4H330*KA Outdoor With FS(M,U)4X30**** Indoor Cooling																								
		Outdoor Ambient Temperature – °F, Dry Bulb																								
		75					85					95					105					115				
		Entering Indoor Temperature – °F, Wet Bulb																								
CFM		72	67	63††	62	57	72	67	63††	62	57	72	67	63††	62	57	72	67	63††	62	57	72	67	63††	62	57
875	MBh †	34.73	31.78	29.62	29.07	27.79	33.11	30.31	28.24	27.72	26.72	31.41	28.75	26.78	26.29	25.58	29.62	27.09	25.22	24.80	24.36	27.66	25.29	23.55	23.20	23.03
	S/T ‡	0.51	0.68	0.71	0.89	1.00	0.51	0.69	0.72	0.90	1.00	0.52	0.71	0.74	0.93	1.00	0.53	0.72	0.75	0.95	1.00	0.54	0.75	0.77	0.98	1.00
	AMPS^	9.70	9.67	9.66	9.65	9.64	10.85	10.82	10.81	10.80	10.79	12.12	12.09	12.07	12.06	12.06	13.51	13.48	13.46	13.45	13.45	15.02	14.99	14.97	14.96	14.96
	HI PR	287	283	280	279	277	330	325	322	321	319	376	372	368	367	366	427	422	419	418	417	482	477	473	473	472
	LO PR	149	136	127	124	119	151	138	129	127	122	154	141	131	129	126	156	143	133	132	130	159	146	136	135	134
1000	MBh †	35.33	32.36	30.19	29.66	28.86	33.65	30.83	28.75	28.27	27.72	31.88	29.20	27.22	26.81	26.50	30.02	27.47	25.60	25.31	25.21	27.99	25.61	23.86	23.78	23.79
	S/T ‡	0.52	0.71	0.73	0.92	1.00	0.52	0.72	0.75	0.95	1.00	0.53	0.74	0.77	0.97	1.00	0.54	0.76	0.79	0.99	1.00	0.56	0.78	0.81	1.00	1.00
	AMPS^	9.90	9.87	9.85	9.85	9.84	11.05	11.02	11.00	11.00	10.99	12.32	12.29	12.27	12.26	12.26	13.71	13.68	13.66	13.65	13.65	15.21	15.19	15.17	15.16	15.17
	HI PR	288	284	281	280	279	331	326	323	322	321	378	373	369	368	368	429	423	420	419	419	483	478	474	474	474
	LO PR	152	139	130	128	124	154	141	132	130	127	157	144	134	132	131	159	146	136	135	135	162	149	139	139	139
1125	MBh †	35.80	32.81	30.63	30.16	29.74	34.05	31.22	29.13	28.75	28.54	32.23	29.53	27.56	27.28	27.26	30.31	27.75	25.89	25.89	25.89	28.22	25.84	24.10	24.40	24.40
	S/T ‡	0.53	0.74	0.76	0.96	1.00	0.54	0.75	0.78	0.98	1.00	0.55	0.77	0.80	1.00	1.00	0.56	0.79	0.82	1.00	1.00	0.57	0.82	0.85	1.00	1.00
	AMPS^	10.10	10.07	10.05	10.05	10.04	11.25	11.22	11.20	11.20	11.19	12.51	12.49	12.47	12.46	12.46	13.90	13.87	13.86	13.85	13.86	15.41	15.39	15.36	15.37	15.37
	HI PR	289	285	281	281	280	332	327	324	323	323	379	374	370	370	370	429	424	420	421	421	484	479	475	476	476
	LO PR	155	142	132	131	129	157	144	134	133	132	159	146	136	135	135	162	149	138	139	139	165	151	141	143	143

† Total capacities are net (I.D. blower heat subtracted) system capacities based on 25' line set.

If additional tubing length and/or indoor unit is located above outdoor unit, a slight variation in capacity may occur.

†† At TVA rating indoor condition (75 °F db, 63 °F wb), all other indoor air temperatures are at 80 °F db

If additional tubing length and/or indoor unit is located above outdoor unit, a slight variation in capacity may occur.

^ System amps are total of indoor and outdoor amps.

‡ Chart data is for 80° F indoor dry bulb. For indoor db temperatures other than 80° F, measure Indoor db and Indoor CFM, and plug these into the formula below. Measure outdoor db and indoor wet bulb, apply these to the chart above, find MBh and S/T, and plug these into the formula below. (Note: if indoor db is the only thing changing, total capacity, MBh, stays the same.)

$$\text{Sensible Capacity at Indoor db LOWER than } 80^\circ \text{ F} = (\text{MBh} \times \text{S/T}) - \left(\frac{(80 - \text{Indoor db}) \times 835 \times \text{Indoor CFM}}{1000} \right)$$

$$\text{Sensible Capacity at Indoor db HIGHER than } 80^\circ \text{ F} = (\text{MBh} \times \text{S/T}) + \left(\frac{(\text{Indoor db} - 80) \times 835 \times \text{Indoor CFM}}{1000} \right)$$

N4H336AKA N4H336GKA		N4H336*KA Outdoor With FS(M,U)4X42**** Indoor Cooling																								
		Outdoor Ambient Temperature – °F, Dry Bulb																								
		75					85					95					105					115				
		Entering Indoor Temperature – °F, Wet Bulb																								
CFM		72	67	63††	62	57	72	67	63††	62	57	72	67	63††	62	57	72	67	63††	62	57	72	67	63††	62	57
1050	MBh †	40.73	37.22	34.65	34.00	33.18	38.83	35.44	32.97	32.37	31.86	36.79	33.56	31.20	30.68	30.45	34.66	31.57	29.33	28.95	28.95	32.34	29.44	27.32	27.33	27.33
	S/T ‡	0.52	0.71	0.74	0.93	1.00	0.52	0.73	0.75	0.96	1.00	0.53	0.74	0.77	0.98	1.00	0.54	0.76	0.79	1.00	1.00	0.55	0.79	0.82	1.00	1.00
	AMPS^	10.90	10.90	10.90	10.90	10.90	12.10	12.09	12.09	12.09	12.09	13.41	13.41	13.40	13.40	13.40	14.86	14.85	14.84	14.84	14.84	16.43	16.42	16.42	16.41	16.41
	HI PR	277	274	271	271	270	319	316	313	312	312	366	362	359	358	358	416	412	409	409	409	471	467	464	464	464
	LO PR	149	137	127	125	122	151	139	129	127	125	154	141	131	130	129	156	143	133	132	132	159	146	136	136	136
1200	MBh †	41.35	37.80	35.22	34.66	34.40	39.36	35.95	33.47	33.01	32.99	37.27	34.00	31.63	31.50	31.50	35.06	31.95	29.70	29.91	29.91	32.66	29.75	27.64	28.19	28.19
	S/T ‡	0.53	0.74	0.77	0.98	1.00	0.54	0.76	0.79	1.00	1.00	0.55	0.78	0.81	1.00	1.00	0.56	0.80	0.83	1.00	1.00	0.58	0.83	0.86	1.00	1.00
	AMPS^	11.16	11.16	11.16	11.15	11.15	12.35	12.34	12.34	12.34	12.34	13.66	13.66	13.66	13.65	13.65	15.11	15.10	15.10	15.09	15.09	16.68	16.67	16.67	16.67	16.67
	HI PR	278	274	272	271	271	320	317	314	313	313	367	363	360	360	360	417	413	410	410	410	472	468	465	466	466
	LO PR	152	140	130	128	127	154	141	132	131	130	157	144	134	134	134	159	146	136	137	137	161	148	138	141	141
1350	MBh †	41.78	38.22	35.62	35.39	35.39	39.74	36.32	33.83	33.91	33.92	37.58	34.31	31.94	32.35	32.35	35.32	32.21	29.96	30.68	30.69	32.87	29.96	27.86	28.88	28.88
	S/T ‡	0.55	0.78	0.80	1.00	1.00	0.56	0.80	0.82	1.00	1.00	0.57	0.82	0.84	1.00	1.00	0.58	0.84	0.87	1.00	1.00	0.60	0.88	0.90	1.00	1.00
	AMPS^	11.41	11.41	11.41	11.41	11.41	12.60	12.60	12.60	12.59	12.59	13.91	13.91	13.91	13.90	13.91	15.36	15.35	15.35	15.35	15.35	16.93	16.92	16.92	16.92	16.92
	HI PR	278	275	273	272	272	321	317	314	315	315	367	363	360	361	361	418	414	411	412	412	473	469	465	467	467
	LO PR	155	142	132	132	132	157	144	134	135	135	159	146	136	138	138	161	148	138	142	142	163	150	140	145	145

† Total capacities are net (I.D. blower heat subtracted) system capacities based on 25' line set.

If additional tubing length and/or indoor unit is located above outdoor unit, a slight variation in capacity may occur.

†† At TVA rating indoor condition (75 °F db, 63 °F wb), all other indoor air temperatures are at 80 °F db

If additional tubing length and/or indoor unit is located above outdoor unit, a slight variation in capacity may occur.

^ System amps are total of indoor and outdoor amps.

‡ Chart data is for 80° F indoor dry bulb. For indoor db temperatures other than 80° F, measure Indoor db and Indoor CFM, and plug these into the formula below. Measure outdoor db and indoor wet bulb, apply these to the chart above, find MBh and S/T, and plug these into the formula below. (Note: if indoor db is the only thing changing, total capacity, MBh, stays the same.)

$$\text{Sensible Capacity at Indoor db LOWER than } 80^\circ \text{ F} = (\text{MBh} \times \text{S/T}) - \left(\frac{(80 - \text{Indoor db}) \times 835 \times \text{Indoor CFM}}{1000} \right)$$

$$\text{Sensible Capacity at Indoor db HIGHER than } 80^\circ \text{ F} = (\text{MBh} \times \text{S/T}) + \left(\frac{(\text{Indoor db} - 80) \times 835 \times \text{Indoor CFM}}{1000} \right)$$

N4H342AKA N4H342GKA		N4H342*KA Outdoor With FS(M,U)4X42**** Indoor Cooling																								
		Outdoor Ambient Temperature – °F, Dry Bulb																								
		75					85					95					105					115				
		Entering Indoor Temperature – °F, Wet Bulb																								
CFM		72	67	63††	62	57	72	67	63††	62	57	72	67	63††	62	57	72	67	63††	62	57	72	67	63††	62	57
1225	MBh †	48.26	44.21	41.23	40.45	39.05	46.00	42.14	39.29	38.56	37.54	43.63	39.96	37.24	36.58	35.93	41.15	37.67	35.09	34.53	34.22	38.47	35.20	32.79	32.38	32.37
	S/T ‡	0.51	0.69	0.72	0.91	1.00	0.52	0.71	0.73	0.93	1.00	0.52	0.72	0.75	0.95	1.00	0.53	0.74	0.77	0.97	1.00	0.54	0.76	0.79	1.00	1.00
	AMPS^	13.40	13.31	13.26	13.25	13.22	14.81	14.74	14.69	14.68	14.67	16.39	16.33	16.29	16.28	16.27	18.14	18.08	18.05	18.04	18.03	20.05	20.01	19.99	19.98	19.98
	HI PR	284	281	279	278	277	327	324	321	321	320	374	371	368	367	367	426	422	419	419	418	482	478	475	475	475
	LO PR	154	141	131	129	125	156	143	133	131	128	159	145	135	133	131	161	148	137	136	135	164	150	140	139	139
1400	MBh †	48.98	44.93	41.93	41.22	40.48	46.64	42.77	39.91	39.28	38.87	44.18	40.50	37.78	37.28	37.16	41.64	38.12	35.55	35.34	35.34	38.84	35.57	33.17	33.37	33.38
	S/T ‡	0.52	0.72	0.75	0.95	1.00	0.53	0.74	0.77	0.97	1.00	0.54	0.76	0.78	0.99	1.00	0.55	0.78	0.80	1.00	1.00	0.56	0.80	0.83	1.00	1.00
	AMPS^	13.72	13.64	13.59	13.58	13.57	15.14	15.07	15.02	15.01	15.01	16.72	16.65	16.61	16.60	16.60	18.47	18.41	18.37	18.37	18.37	20.36	20.33	20.31	20.31	20.31
	HI PR	285	282	279	279	278	328	325	322	321	321	375	372	369	368	368	427	423	420	420	420	482	478	476	476	476
	LO PR	158	144	134	132	130	160	146	136	134	133	162	148	138	137	136	164	150	140	140	140	167	153	142	144	144
1575	MBh †	49.51	45.43	42.44	41.88	41.65	47.10	43.21	40.35	39.96	39.96	44.56	40.87	38.16	38.15	38.15	41.96	38.43	35.87	36.24	36.24	39.08	35.82	33.43	34.17	34.18
	S/T ‡	0.54	0.75	0.78	0.99	1.00	0.55	0.77	0.80	1.00	1.00	0.56	0.79	0.82	1.00	1.00	0.57	0.82	0.84	1.00	1.00	0.58	0.84	0.87	1.00	1.00
	AMPS^	14.05	13.97	13.91	13.91	13.90	15.47	15.40	15.34	15.34	15.34	17.04	16.97	16.93	16.93	16.93	18.79	18.73	18.69	18.69	18.69	20.68	20.65	20.62	20.63	20.63
	HI PR	286	282	280	280	279	329	325	323	322	322	376	372	369	369	369	428	423	421	421	421	483	479	476	477	477
	LO PR	160	147	137	135	135	162	149	138	138	138	164	151	140	141	141	166	153	142	144	144	169	155	145	148	148

- † Total capacities are net (I.D. blower heat subtracted) system capacities based on 25' line set.
If additional tubing length and/or indoor unit is located above outdoor unit, a slight variation in capacity may occur.
- †† At TVA rating indoor condition (75 °F db, 63 °F wb), all other indoor air temperatures are at 80 °F db
If additional tubing length and/or indoor unit is located above outdoor unit, a slight variation in capacity may occur.
- ^ System amps are total of indoor and outdoor amps.
- ‡ Chart data is for 80° F indoor dry bulb. For indoor db temperatures other than 80° F, measure Indoor db and Indoor CFM, and plug these into the formula below. Measure outdoor db and indoor wet bulb, apply these to the chart above, find MBh and S/T, and plug these into the formula below. (Note: if indoor db is the only thing changing, total capacity, MBh, stays the same.)

$$\text{Sensible Capacity at Indoor db LOWER than } 80^\circ\text{F} = (\text{MBh} \times \text{S/T}) - \left(\frac{(80 - \text{Indoor db}) \times 835 \times \text{Indoor CFM}}{1000} \right)$$

$$\text{Sensible Capacity at Indoor db HIGHER than } 80^\circ\text{F} = (\text{MBh} \times \text{S/T}) + \left(\frac{(\text{Indoor db} - 80) \times 835 \times \text{Indoor CFM}}{1000} \right)$$

N4H348AKA N4H348GKA		N4H348*KA Outdoor With FS(M,U)4X48**** Indoor Cooling																								
		Outdoor Ambient Temperature – °F, Dry Bulb																								
		75					85					95					105					115				
		Entering Indoor Temperature – °F, Wet Bulb																								
CFM		72	67	63††	62	57	72	67	63††	62	57	72	67	63††	62	57	72	67	63††	62	57	72	67	63††	62	57
1400	MBh †	55.40	50.66	47.16	46.25	44.75	52.85	48.32	44.97	44.12	43.04	50.16	45.85	42.65	41.87	41.21	47.32	43.23	40.18	39.52	39.26	44.24	40.39	37.54	37.13	37.13
	S/T ‡	0.51	0.70	0.72	0.91	1.00	0.52	0.71	0.74	0.93	1.00	0.52	0.72	0.75	0.96	1.00	0.53	0.74	0.77	0.98	1.00	0.54	0.77	0.79	1.00	1.00
	AMPS^	14.26	14.24	14.22	14.21	14.21	15.82	15.80	15.78	15.78	15.77	17.55	17.54	17.52	17.51	17.51	19.46	19.45	19.43	19.42	19.42	21.55	21.54	21.52	21.52	21.52
	HI PR	277	273	270	269	268	320	315	312	311	310	366	361	358	357	356	417	412	407	407	406	471	466	462	461	461
	LO PR	156	143	133	131	126	158	145	135	133	129	160	147	137	135	133	163	149	139	137	136	165	151	141	140	140
1600	MBh †	56.26	51.50	47.98	47.16	46.44	53.63	49.07	45.70	44.97	44.61	50.81	46.50	43.28	42.69	42.67	47.87	43.77	40.73	40.59	40.59	44.68	40.83	37.99	38.33	38.34
	S/T ‡	0.53	0.73	0.75	0.96	1.00	0.53	0.74	0.77	0.98	1.00	0.54	0.76	0.79	1.00	1.00	0.55	0.78	0.81	1.00	1.00	0.57	0.81	0.84	1.00	1.00
	AMPS^	14.63	14.60	14.58	14.58	14.58	16.19	16.16	16.15	16.14	16.14	17.92	17.90	17.88	17.88	17.88	19.82	19.81	19.79	19.79	19.79	21.91	21.90	21.89	21.89	21.89
	HI PR	278	274	271	271	270	321	317	313	312	312	367	363	359	358	358	418	413	409	409	409	472	467	463	464	464
	LO PR	159	146	136	134	132	161	148	138	136	135	163	150	139	138	138	166	152	142	142	142	168	154	144	145	145
1800	MBh †	56.87	52.10	48.58	47.96	47.82	54.16	49.59	46.22	45.90	45.90	51.25	46.94	43.74	43.85	43.86	48.26	44.13	41.11	41.66	41.67	44.97	41.13	38.30	39.30	39.30
	S/T ‡	0.54	0.76	0.78	0.99	1.00	0.55	0.78	0.80	1.00	1.00	0.56	0.80	0.82	1.00	1.00	0.57	0.82	0.85	1.00	1.00	0.59	0.85	0.88	1.00	1.00
	AMPS^	14.99	14.97	14.95	14.95	14.94	16.55	16.53	16.51	16.51	16.51	18.28	18.26	18.25	18.25	18.25	20.19	20.17	20.16	20.16	20.16	22.27	22.26	22.25	22.26	22.26
	HI PR	279	275	272	272	271	322	317	314	314	314	368	363	360	360	360	419	414	409	410	410	473	468	464	465	465
	LO PR	162	148	138	137	137	164	150	140	140	140	166	152	142	143	143	168	154	144	146	146	170	156	146	150	150

† Total capacities are net (I.D. blower heat subtracted) system capacities based on 25' line set.

If additional tubing length and/or indoor unit is located above outdoor unit, a slight variation in capacity may occur.

†† At TVA rating indoor condition (75 °F db, 63 °F wb), all other indoor air temperatures are at 80 °F db

If additional tubing length and/or indoor unit is located above outdoor unit, a slight variation in capacity may occur.

^ System amps are total of indoor and outdoor amps.

‡ Chart data is for 80° F indoor dry bulb. For indoor db temperatures other than 80° F, measure Indoor db and Indoor CFM, and plug these into the formula below. Measure outdoor db and indoor wet bulb, apply these to the chart above, find MBh and S/T, and plug these into the formula below. (Note: if indoor db is the only thing changing, total capacity, MBh, stays the same.)

$$\text{Sensible Capacity at Indoor db LOWER than } 80^\circ \text{ F} = (\text{MBh} \times \text{S/T}) - \left(\frac{(80 - \text{Indoor db}) \times 835 \times \text{Indoor CFM}}{1000} \right)$$

$$\text{Sensible Capacity at Indoor db HIGHER than } 80^\circ \text{ F} = (\text{MBh} \times \text{S/T}) + \left(\frac{(\text{Indoor db} - 80) \times 835 \times \text{Indoor CFM}}{1000} \right)$$

N4H360AKA N4H360GKA		N4H360°KA Outdoor With FS(M,U)4X60**** Indoor Cooling																								
		Outdoor Ambient Temperature – °F, Dry Bulb																								
		75					85					95					105					115				
		Entering Indoor Temperature – °F, Wet Bulb																								
CFM		72	67	63††	62	57	72	67	63††	62	57	72	67	63††	62	57	72	67	63††	62	57	72	67	63††	62	57
1750	MBh †	71.08	65.19	60.79	59.61	57.48	67.69	62.05	57.85	56.75	55.20	64.09	58.73	54.78	53.77	52.79	60.33	55.30	51.57	50.69	50.24	56.30	51.61	48.15	47.50	47.49
	S/T ‡	0.51	0.69	0.72	0.90	1.00	0.51	0.70	0.73	0.92	1.00	0.52	0.72	0.75	0.95	1.00	0.53	0.74	0.76	0.97	1.00	0.54	0.76	0.79	1.00	1.00
	AMPS^	19.19	18.94	18.76	18.71	18.63	21.14	20.90	20.71	20.67	20.60	23.29	23.05	22.87	22.83	22.78	25.66	25.43	25.24	25.21	25.19	28.24	28.02	27.84	27.82	27.82
	HI PR	292	287	283	282	280	336	330	326	325	323	383	377	373	372	371	435	429	424	423	422	490	484	479	478	478
	LO PR	154	141	131	129	125	157	143	133	131	128	159	146	135	133	131	162	148	138	136	135	164	150	140	139	139
2000	MBh †	72.12	66.24	61.83	60.73	59.63	68.55	62.96	58.77	57.79	57.18	64.87	59.50	55.56	54.77	54.60	60.98	55.93	52.22	51.88	51.89	56.80	52.11	48.67	48.94	48.94
	S/T ‡	0.52	0.72	0.75	0.95	1.00	0.53	0.74	0.76	0.97	1.00	0.54	0.75	0.78	0.99	1.00	0.55	0.78	0.80	1.00	1.00	0.56	0.80	0.83	1.00	1.00
	AMPS^	19.74	19.50	19.31	19.27	19.22	21.69	21.44	21.26	21.22	21.19	23.84	23.60	23.41	23.38	23.37	26.20	25.97	25.78	25.78	25.78	28.78	28.56	28.38	28.40	28.40
	HI PR	293	288	284	283	282	337	332	327	326	326	385	379	374	373	373	436	430	425	425	425	492	485	480	481	481
	LO PR	158	145	134	133	130	160	147	136	135	133	162	149	138	137	137	165	151	140	140	140	167	153	143	144	144
2250	MBh †	72.83	66.96	62.58	61.68	61.37	69.16	63.58	59.40	58.79	58.79	65.40	60.01	56.09	56.05	56.06	61.39	56.35	52.66	53.19	53.19	57.10	52.43	49.01	50.08	50.08
	S/T ‡	0.54	0.75	0.78	0.99	1.00	0.54	0.77	0.79	1.00	1.00	0.56	0.79	0.81	1.00	1.00	0.57	0.81	0.84	1.00	1.00	0.58	0.84	0.87	1.00	1.00
	AMPS^	20.28	20.03	19.84	19.81	19.80	22.22	21.98	21.79	21.77	21.77	24.37	24.13	23.94	23.95	23.95	26.73	26.50	26.32	26.35	26.35	29.30	29.08	28.91	28.97	28.97
	HI PR	294	289	285	284	284	338	333	328	328	328	386	380	375	375	375	437	431	426	427	427	493	486	482	483	483
	LO PR	161	147	137	136	135	163	149	139	138	138	165	151	141	141	141	167	153	143	145	145	169	156	145	149	149

† Total capacities are net (I.D. blower heat subtracted) system capacities based on 25' line set.

If additional tubing length and/or indoor unit is located above outdoor unit, a slight variation in capacity may occur.

†† At TVA rating indoor condition (75 °F db, 63 °F wb), all other indoor air temperatures are at 80 °F db

If additional tubing length and/or indoor unit is located above outdoor unit, a slight variation in capacity may occur.

^ System amps are total of indoor and outdoor amps.

‡ Chart data is for 80° F indoor dry bulb. For indoor db temperatures other than 80° F, measure Indoor db and Indoor CFM, and plug these into the formula below. Measure outdoor db and indoor wet bulb, apply these to the chart above, find MBh and S/T, and plug these into the formula below. (Note: if indoor db is the only thing changing, total capacity, MBh, stays the same.)

$$\text{Sensible Capacity at Indoor db LOWER than } 80^\circ \text{ F} = (\text{MBh} \times \text{S/T}) - \left(\frac{(80 - \text{Indoor db}) \times 835 \times \text{Indoor CFM}}{1000} \right)$$

$$\text{Sensible Capacity at Indoor db HIGHER than } 80^\circ \text{ F} = (\text{MBh} \times \text{S/T}) + \left(\frac{(\text{Indoor db} - 80) \times 835 \times \text{Indoor CFM}}{1000} \right)$$

N4H318AKA N4H318GKA		N4H318*KA Outdoor With FS(M,U)4X18**** Indoor Heating																																							
		Outdoor Ambient Temperature – °F, Dry Bulb																																							
		– 3					7					17					27					37					47					57					67				
		Entering Indoor Temperature – °F, Wet Bulb																																							
CFM		65	70	75	65	70	75	65	70	75	65	70	75	65	70	75	65	70	75	65	70	75	65	70	75																
525	MBh †	6.44	6.10	5.74	8.40	8.11	7.80	10.48	10.21	9.92	12.70	12.43	12.16	15.22	14.90	14.59	18.03	17.68	17.35	20.70	20.48	20.22	23.24	23.00	22.73																
	T/R	12.70	12.10	11.50	16.60	16.20	15.70	20.90	20.50	20.10	25.60	25.20	24.90	30.90	30.50	30.10	37.00	36.60	36.20	43.00	42.90	42.70	48.70	48.60	48.50																
	AMPS^	5.40	5.60	5.81	5.63	5.87	6.11	5.84	6.11	6.38	6.06	6.35	6.65	6.34	6.65	6.97	6.70	7.03	7.37	6.98	7.35	7.72	7.34	7.71	8.10																
	HI PR	225	240	256	241	257	273	258	275	293	278	296	315	304	322	342	335	354	375	361	384	407	392	415	439																
	LO PR	40	40	40	51	52	52	64	65	65	79	79	80	96	96	96	114	114	115	131	133	134	147	149	150																
600	MBh †	6.60	6.26	5.90	8.58	8.29	7.98	10.67	10.38	10.12	12.94	12.66	12.38	15.54	15.18	14.86	18.34	18.00	17.67	20.75	20.54	20.39	23.24	23.06	22.84																
	T/R	11.30	10.80	10.30	14.80	14.40	14.00	18.60	18.20	17.90	22.70	22.40	22.10	27.50	27.00	26.70	32.70	32.40	32.00	37.30	37.30	37.30	42.20	42.20	42.20																
	AMPS^	5.48	5.69	5.89	5.68	5.92	6.17	5.86	6.13	6.40	6.05	6.33	6.63	6.30	6.59	6.91	6.58	6.91	7.25	6.80	7.15	7.53	7.10	7.47	7.85																
	HI PR	222	237	253	236	252	269	251	268	286	269	287	306	293	311	330	320	340	360	342	363	387	369	392	415																
	LO PR	40	40	40	51	51	52	64	65	65	79	79	80	95	96	96	113	114	114	128	130	132	144	146	148																
675	MBh †	6.75	6.41	6.05	8.74	8.45	8.12	10.83	10.56	10.29	13.15	12.84	12.57	0.00	15.42	15.10	18.54	18.26	17.94	20.79	20.60	20.42	23.11	23.00	22.84																
	T/R	10.30	9.80	9.40	13.40	13.00	12.60	16.70	16.40	16.10	20.40	20.10	19.80	24.50	24.30	24.00	29.20	29.00	28.70	33.00	33.00	33.00	36.90	37.10	37.20																
	AMPS^	5.57	5.78	5.99	5.74	5.99	6.24	5.90	6.17	6.45	6.06	6.35	6.64	0.00	6.58	6.89	6.50	6.84	7.19	6.71	7.05	7.41	6.96	7.32	7.70																
	HI PR	219	234	250	232	248	265	246	263	281	263	280	299	–15	302	321	307	328	349	328	349	371	351	374	397																
	LO PR	40	40	40	51	51	52	64	64	65	79	79	79	–15	95	96	112	113	114	126	128	130	140	143	145																

† Total capacities are net (I.D. blower heat subtracted) system capacities based on 25' line set.
If additional tubing length and/or indoor unit is located above outdoor unit, a slight variation in capacity may occur.

^ System amps are total of indoor and outdoor amps.

N4H324AKA N4H324GKA		N4H324*KA Outdoor With FS(M,U)4X24**** Indoor Heating																																							
		Outdoor Ambient Temperature – °F, Dry Bulb																																							
		– 3					7					17					27					37					47					57					67				
		Entering Indoor Temperature – °F, Wet Bulb																																							
CFM		65	70	75	65	70	75	65	70	75	65	70	75	65	70	75	65	70	75	65	70	75	65	70	75																
700	MBh †	9.58	9.29	8.96	11.98	11.70	11.40	14.58	14.30	14.02	17.51	17.18	16.85	20.82	20.47	20.14	24.20	23.95	23.63	27.14	26.95	26.71	30.15	30.01	29.80																
	T/R	14.30	14.00	13.60	18.00	17.70	17.40	22.10	21.90	21.60	26.80	26.50	26.20	32.10	31.80	31.60	37.70	37.60	37.40	42.70	42.70	42.70	47.80	48.00	48.10																
	AMPS^	6.62	6.93	7.24	6.91	7.24	7.59	7.21	7.58	7.96	7.60	7.98	8.37	8.08	8.48	8.90	8.51	8.97	9.44	8.95	9.42	9.91	9.44	9.95	10.46																
	HI PR	233	250	267	248	265	283	265	283	301	286	305	324	312	331	352	336	358	381	361	384	408	389	414	438																
	LO PR	39	39	39	50	50	50	62	63	63	77	77	77	92	93	93	108	110	111	122	124	125	136	138	140																
800	MBh †	9.77	9.48	9.15	12.19	11.91	11.61	14.81	14.53	14.25	17.80	17.46	17.13	21.14	20.79	20.44	24.17	24.00	23.84	26.94	26.83	26.68	29.60	29.61	29.54																
	T/R	12.70	12.50	12.10	16.00	15.70	15.50	19.50	19.30	19.10	23.70	23.40	23.20	28.30	28.10	27.90	32.70	32.70	32.80	36.70	36.80	37.00	40.60	41.00	41.20																
	AMPS^	6.68	7.00	7.31	6.94	7.28	7.63	7.21	7.57	7.95	7.56	7.93	8.32	8.00	8.39	8.80	8.32	8.76	9.23	8.70	9.16	9.64	9.08	9.58	10.09																
	HI PR	229	245	262	242	259	277	257	275	293	277	295	314	300	319	339	319	341	363	341	364	387	363	388	413																
	LO PR	38	39	39	50	50	50	62	62	63	76	77	77	92	92	93	106	108	109	119	121	123	131	133	136																
900	MBh †	9.94	9.65	9.33	12.37	12.09	11.80	15.03	14.73	14.45	18.06	17.71	17.37	21.40	21.06	20.71	24.07	23.97	23.82	26.59	26.60	26.53	28.87	29.03	29.10																
	T/R	11.50	11.20	11.00	14.40	14.20	13.90	17.60	17.40	17.20	21.20	21.00	20.80	25.40	25.20	25.00	28.70	28.90	28.90	31.90	32.20	32.40	34.80	35.40	35.80																
	AMPS^	6.77	7.08	7.40	7.00	7.34	7.69	7.25	7.60	7.98	7.57	7.94	8.32	7.95	8.37	8.77	8.22	8.66	9.10	8.55	9.00	9.48	8.84	9.34	9.85																
	HI PR	226	242	259	237	254	272	251	269	287	270	288	306	290	310	330	307	328	350	326	348	371	343	368	393																
	LO PR	38	39	39	49	50	50	62	62	63	76	77	77	92	92	93	104	106	107	115	118	120	125	129	132																

† Total capacities are net (I.D. blower heat subtracted) system capacities based on 25' line set.
If additional tubing length and/or indoor unit is located above outdoor unit, a slight variation in capacity may occur.

^ System amps are total of indoor and outdoor amps.

N4H330AKA N4H330GKA		N4H330*KA Outdoor With FS(M,U)4X30**** Indoor Heating																																							
		Outdoor Ambient Temperature – °F, Dry Bulb																																							
		– 3					7					17					27					37					47					57					67				
		Entering Indoor Temperature – °F, Wet Bulb																																							
CFM		65	70	75	65	70	75	65	70	75	65	70	75	65	70	75	65	70	75	65	70	75	65	70	75																
875	MBh †	12.79	12.32	11.81	16.02	15.60	15.15	19.46	19.06	18.63	23.12	22.74	22.33	27.25	26.76	26.29	31.79	31.27	30.78	37.07	36.43	35.80	42.79	42.19	41.54																
	T/R	15.00	14.60	14.10	18.90	18.60	18.20	23.20	22.90	22.60	27.80	27.60	27.30	33.10	32.70	32.40	39.00	38.60	38.40	46.00	45.60	45.10	53.80	53.50	53.10																
	AMPS^	9.06	9.45	9.84	9.53	9.96	10.41	10.00	10.49	10.98	10.54	11.06	11.60	11.18	11.72	12.29	11.96	12.54	13.15	12.96	13.57	14.20	13.91	14.59	15.28																
	HI PR	239	255	271	255	272	290	274	292	311	296	315	335	323	342	363	355	376	398	395	416	439	435	459	483																
	LO PR	37	38	38	48	48	49	60	61	61	74	74	75	89	90	90	106	106	107	125	126	126	146	147	148																
1000	MBh †	13.05	12.59	12.08	16.31	15.89	15.43	19.78	19.38	18.96	23.49	23.09	22.69	27.71	27.20	26.72	32.34	31.80	31.28	37.78	37.12	36.49	43.34	42.77	42.21																
	T/R	13.40	13.00	12.60	16.80	16.50	16.20	20.50	20.30	20.00	24.50	24.30	24.10	29.20	28.90	28.60	34.40	34.10	33.80	40.60	40.30	39.90	47.20	46.90	46.70																
	AMPS^	9.14	9.54	9.93	9.56	10.00	10.45	9.98	10.46	10.96	10.45	10.97	11.50	11.03	11.56	12.12	11.72	12.29	12.89	12.61	13.23	13.85	13.40	14.06	14.75																
	HI PR	234	250	267	249	266	284	266	284	302	285	304	324	310	329	350	339	360	381	375	397	419	409	433	457																
	LO PR	37	38	38	48	48	49	60	60	61	74	74	75	89	89	90	105	106	107	125	125	126	144	145	146																
1125	MBh †	13.29	12.83	12.32	16.56	16.15	15.70	20.05	19.66	19.24	23.81	23.39	23.00	28.06	27.64	27.10	32.80	32.25	31.71	38.30	37.70	37.04	43.65	43.16	42.60																
	T/R	12.10	11.70	11.40	15.10	14.90	14.60	18.40	18.20	18.00	22.00	21.80	21.60	26.20	26.00	25.70	30.80	30.60	30.30	36.40	36.10	35.70	41.80	41.70	41.50																
	AMPS^	9.25	9.65	10.04	9.62	10.07	10.52	10.00	10.48	10.98	10.42	10.94	11.47	10.95	11.49	12.03	11.59	12.15	12.73	12.34	12.97	13.63	13.09	13.73	14.39																
	HI PR	230	247	263	244	261	279	259	277	296	278	296	316	300	320	339	327	348	369	359	381	404	391	414	437																
	LO PR	37	37	38	48	48	49	60	60	61	74	74	74	88	89	90	105	106	106	124	125	126	143	144	145																

† Total capacities are net (I.D. blower heat subtracted) system capacities based on 25' line set.
If additional tubing length and/or indoor unit is located above outdoor unit, a slight variation in capacity may occur.

^ System amps are total of indoor and outdoor amps.

N4H336AKA N4H336GKA		N4H336*KA Outdoor With FS(M,U)4X42**** Indoor Heating																																							
		Outdoor Ambient Temperature – °F, Dry Bulb																																							
		– 3					7					17					27					37					47					57					67				
		Entering Indoor Temperature – °F, Wet Bulb																																							
CFM		65	70	75	65	70	75	65	70	75	65	70	75	65	70	75	65	70	75	65	70	75	65	70	75																
1050	MBh †	14.42	13.90	13.33	18.07	17.58	17.07	21.93	21.48	21.00	26.06	25.62	25.17	30.80	30.21	29.67	35.94	35.42	34.85	40.65	40.20	39.73	45.56	45.16	44.72																
	T/R	13.90	13.60	13.10	17.60	17.20	16.90	21.50	21.20	20.90	25.70	25.50	25.30	30.70	30.40	30.10	36.20	35.90	35.70	41.30	41.20	41.00	46.70	46.70	46.60																
	AMPS^	10.04	10.43	10.82	10.44	10.88	11.33	10.86	11.33	11.82	11.32	11.83	12.36	11.90	12.41	12.96	12.44	13.05	13.67	13.00	13.61	14.24	13.68	14.33	14.99																
	HI PR	230	245	262	244	261	278	260	278	296	280	298	317	304	322	342	327	349	371	352	374	396	381	404	428																
	LO PR	37	38	38	48	49	49	60	61	61	74	75	75	90	90	91	106	107	108	121	122	124	137	138	140																
1200	MBh †	14.73	14.21	13.65	18.39	17.92	17.42	22.28	21.84	21.37	26.48	26.00	25.56	31.28	30.77	30.16	36.09	35.80	35.37	40.59	40.30	39.94	45.17	45.00	44.67																
	T/R	12.40	12.10	11.70	15.60	15.30	15.00	19.00	18.80	18.60	22.80	22.50	22.40	27.10	26.90	26.60	31.50	31.50	31.40	35.70	35.80	35.80	40.10	40.30	40.30																
	AMPS^	10.19	10.59	10.98	10.55	10.99	11.44	10.91	11.39	11.88	11.33	11.83	12.35	11.85	12.37	12.90	12.25	12.84	13.46	12.75	13.36	13.98	13.30	13.95	14.61																
	HI PR	226	242	258	238	255	273	253	270	289	271	289	308	293	312	331	312	333	355	334	355	378	358	381	405																
	LO PR	37	38	38	48	48	49	60	61	61	74	75	75	89	90	90	105	106	107	119	120	122	133	135	137																
1350	MBh †	15.01	14.50	13.93	18.68	18.22	17.72	22.60	22.16	21.71	26.84	26.37	25.92	31.71	31.18	30.58	36.12	35.83	35.60	40.35	40.17	39.93	44.12	44.49	44.35																
	T/R	11.20	10.90	10.60	14.10	13.80	13.60	17.10	16.90	16.70	20.40	20.20	20.10	24.30	24.10	23.80	27.90	27.90	27.90	31.30	31.50	31.50	34.40	35.10	35.30																
	AMPS^	10.36	10.76	11.16	10.68	11.13	11.58	11.01	11.48	11.97	11.39	11.88	12.40	11.85	12.39	12.91	12.19	12.75	13.36	12.62	13.22	13.84	13.03	13.72	14.37																
	HI PR	222	238	255	234	251	268	248	265	283	264	282	301	284	303	322	300	321	342	320	341	363	338	363	387																
	LO PR	37	38	38	48	48	49	60	61	61	74	74	75	89	90	90	103	104	106	116	118	120	127	131	133																

† Total capacities are net (I.D. blower heat subtracted) system capacities based on 25' line set.
If additional tubing length and/or indoor unit is located above outdoor unit, a slight variation in capacity may occur.

^ System amps are total of indoor and outdoor amps.

N4H342AKA N4H342GKA		N4H342*KA Outdoor With FS(M,U)4X42**** Indoor Heating																																							
		Outdoor Ambient Temperature – °F, Dry Bulb																																							
		– 3					7					17					27					37					47					57					67				
		Entering Indoor Temperature – °F, Wet Bulb																																							
CFM		65	70	75	65	70	75	65	70	75	65	70	75	65	70	75	65	70	75	65	70	75	65	70	75																
1225	MBh †	17.53	17.06	16.54	21.61	21.17	20.69	26.00	25.58	25.13	30.74	30.29	29.85	36.21	35.68	35.03	42.09	41.58	41.04	47.60	47.11	46.60	53.07	52.62	52.13																
	T/R	14.50	14.30	13.90	18.00	17.80	17.60	21.80	21.70	21.50	26.00	25.90	25.70	30.90	30.70	30.40	36.30	36.10	36.00	41.40	41.30	41.20	46.60	46.60	46.50																
	AMPS^	11.81	12.34	12.88	12.28	12.86	13.45	12.81	13.42	14.05	13.41	14.06	14.73	14.17	14.85	15.52	14.92	15.67	16.45	15.64	16.40	17.19	16.49	17.29	18.12																
	HI PR	234	251	268	249	266	284	265	283	302	285	304	324	310	330	349	334	356	378	359	381	404	387	410	434																
	LO PR	36	36	36	46	47	47	58	59	59	72	72	73	87	87	88	103	104	105	118	119	120	132	134	135																
1400	MBh †	17.88	17.40	16.89	21.99	21.52	21.08	26.39	25.97	25.53	31.20	30.69	30.29	36.75	36.21	35.58	42.44	42.00	41.57	47.57	47.24	46.84	52.73	52.50	52.10																
	T/R	12.90	12.70	12.40	16.00	15.80	15.60	19.30	19.20	19.00	23.00	22.80	22.70	27.30	27.10	26.90	31.80	31.70	31.60	35.90	35.90	35.90	40.00	40.20	40.30																
	AMPS^	11.97	12.51	13.05	12.40	12.98	13.57	12.87	13.47	14.10	13.41	14.04	14.71	14.11	14.77	15.43	14.69	15.42	16.18	15.33	16.08	16.86	16.04	16.84	17.65																
	HI PR	230	246	263	243	260	278	258	276	295	276	294	314	298	318	338	318	339	362	340	362	385	364	387	411																
	LO PR	36	36	36	46	47	47	58	59	59	72	72	73	87	87	88	102	103	104	115	117	118	129	131	132																
1575	MBh †	18.21	17.74	17.21	22.32	21.88	21.41	26.75	26.32	25.90	31.61	31.11	30.67	37.22	36.68	36.15	42.50	42.19	41.81	47.37	47.15	46.84	52.15	52.04	51.83																
	T/R	11.70	11.50	11.20	14.40	14.20	14.00	17.30	17.20	17.10	20.60	20.50	20.30	24.40	24.30	24.10	28.10	28.10	28.10	31.50	31.60	31.70	34.90	35.10	35.30																
	AMPS^	12.17	12.71	13.25	12.55	13.13	13.72	12.98	13.59	14.21	13.48	14.10	14.76	14.14	14.79	15.48	14.60	15.31	16.05	15.17	15.91	16.68	15.78	16.56	17.36																
	HI PR	227	243	260	238	256	273	252	270	289	269	287	307	290	309	329	307	327	349	326	348	370	347	370	393																
	LO PR	36	36	36	46	47	47	58	59	59	72	72	72	87	87	87	100	102	103	113	115	116	125	127	129																

† Total capacities are net (I.D. blower heat subtracted) system capacities based on 25' line set.
If additional tubing length and/or indoor unit is located above outdoor unit, a slight variation in capacity may occur.

^ System amps are total of indoor and outdoor amps.

N4H348AKA N4H348GKA		N4H348*KA Outdoor With FS(M,U)4X48**** Indoor Heating																																							
		Outdoor Ambient Temperature – °F, Dry Bulb																																							
		– 3					7					17					27					37					47					57					67				
		Entering Indoor Temperature – °F, Wet Bulb																																							
CFM		65	70	75	65	70	75	65	70	75	65	70	75	65	70	75	65	70	75	65	70	75	65	70	75																
1400	MBh †	21.02	20.52	19.98	25.66	25.21	24.76	30.63	30.19	29.75	36.31	35.74	35.19	42.60	41.99	41.42	48.84	48.41	48.00	54.32	54.98	54.51	56.50	57.35	58.18																
	T/R	15.20	15.00	14.70	18.70	18.50	18.30	22.40	22.30	22.20	26.80	26.60	26.40	31.70	31.60	31.40	36.70	36.70	36.70	41.20	42.10	42.10	42.90	44.10	45.20																
	AMPS^	13.71	14.29	14.88	14.21	14.85	15.51	14.76	15.45	16.16	15.43	16.13	16.87	16.10	16.94	17.76	16.84	17.65	18.50	17.60	18.63	19.51	17.81	18.88	20.02																
	HI PR	234	251	268	248	265	284	264	283	302	286	304	324	309	330	351	333	354	376	358	386	408	365	394	425																
	LO PR	37	37	37	47	47	48	59	60	60	73	73	74	88	89	89	103	104	105	115	119	120	120	124	128																
1600	MBh †	21.41	20.92	20.37	26.07	25.62	25.14	31.08	30.62	30.19	36.82	36.31	35.69	43.01	42.58	42.01	48.80	48.50	48.14	51.13	52.26	53.06	52.63	53.93	54.85																
	T/R	13.50	13.30	13.10	16.50	16.40	16.20	19.80	19.70	19.60	23.70	23.50	23.30	27.80	27.80	27.70	31.80	31.90	32.00	33.40	34.50	35.40	34.50	35.70	36.70																
	AMPS^	13.91	14.49	15.09	14.36	14.99	15.65	14.84	15.53	16.24	15.45	16.16	16.87	15.99	16.76	17.59	16.69	17.48	18.30	16.91	17.93	18.97	17.01	18.05	19.11																
	HI PR	229	246	263	242	259	277	257	275	294	277	296	314	296	316	337	320	340	362	327	355	383	331	360	388																
	LO PR	36	37	37	47	47	48	59	60	60	73	73	74	87	88	89	101	102	103	106	110	115	109	114	118																
1800	MBh †	21.77	21.28	20.76	26.44	26.01	25.53	31.50	31.03	30.60	37.27	36.75	36.15	43.11	42.83	42.46	47.24	48.16	48.15	48.26	49.40	50.73	49.37	50.74	52.17																
	T/R	12.20	12.00	11.80	14.90	14.70	14.60	17.80	17.70	17.60	21.20	21.10	20.90	24.70	24.70	24.70	27.20	28.00	28.20	27.80	28.70	29.80	28.40	29.50	30.70																
	AMPS^	14.14	14.73	15.33	14.55	15.18	15.84	15.00	15.67	16.38	15.57	16.27	16.97	16.04	16.78	17.57	16.49	17.42	18.26	16.53	17.49	18.53	16.57	17.56	18.62																
	HI PR	226	243	260	237	254	273	252	269	288	271	289	307	288	307	328	303	329	351	305	331	360	307	334	363																
	LO PR	36	37	37	47	47	48	59	59	60	73	73	73	86	87	88	96	100	102	98	102	107	100	105	110																

† Total capacities are net (I.D. blower heat subtracted) system capacities based on 25' line set.
If additional tubing length and/or indoor unit is located above outdoor unit, a slight variation in capacity may occur.

^ System amps are total of indoor and outdoor amps.

N4H360AKA N4H360GKA		N4H360*KA Outdoor With FS(M,U)4X60**** Indoor Heating																																							
		Outdoor Ambient Temperature – °F, Dry Bulb																																							
		– 3					7					17					27					37					47					57					67				
		Entering Indoor Temperature – °F, Wet Bulb																																							
CFM		65	70	75	65	70	75	65	70	75	65	70	75	65	70	75	65	70	75	65	70	75	65	70	75																
1750	MBh †	25.07	24.34	23.57	30.90	30.22	29.50	37.17	36.54	35.86	43.81	43.21	42.56	51.11	50.41	49.72	59.85	58.98	57.81	68.95	68.13	67.28	78.00	77.06	76.15																
	T/R	14.10	13.90	13.50	17.50	17.30	17.00	21.20	21.10	20.90	25.20	25.10	24.90	29.70	29.50	29.40	35.10	34.90	34.40	40.80	40.70	40.50	46.70	46.50	46.30																
	AMPS^	16.76	17.53	18.33	17.39	18.21	19.05	18.10	18.96	19.87	18.87	19.79	20.74	19.75	20.71	21.71	20.83	21.88	22.89	21.82	22.87	23.95	23.10	24.18	25.31																
	HI PR	230	246	263	243	260	278	257	275	294	275	294	313	295	315	335	318	339	360	342	363	385	371	393	416																
	LO PR	34	34	34	44	44	44	55	55	56	68	68	68	82	82	83	98	98	99	115	115	116	131	132	133																
2000	MBh †	25.62	24.89	24.12	31.49	30.80	30.09	37.79	37.17	36.50	44.47	43.87	43.24	51.96	51.17	50.48	60.88	60.00	58.94	69.47	68.71	67.93	78.33	77.50	76.69																
	T/R	12.60	12.40	12.10	15.60	15.40	15.20	18.80	18.70	18.50	22.30	22.20	22.00	26.20	26.00	25.90	31.00	30.80	30.50	35.70	35.60	35.50	40.60	40.50	40.40																
	AMPS^	17.07	17.84	18.64	17.64	18.45	19.29	18.26	19.12	20.02	18.94	19.85	20.79	19.74	20.67	21.66	20.59	21.60	22.67	21.51	22.54	23.60	22.61	23.67	24.78																
	HI PR	226	242	259	237	255	272	250	268	286	266	285	304	284	303	323	303	324	345	325	346	368	350	372	395																
	LO PR	33	34	34	43	44	44	55	55	55	67	68	68	82	82	82	98	98	98	113	114	115	129	130	131																
2250	MBh †	26.13	25.40	24.63	32.03	31.34	30.63	38.34	37.72	37.07	45.07	44.46	43.83	52.72	51.85	51.15	61.49	60.72	59.80	69.75	69.06	68.35	77.76	77.77	76.95																
	T/R	11.40	11.20	10.90	14.10	13.90	13.70	16.90	16.80	16.60	20.00	19.90	19.80	23.50	23.40	23.20	27.70	27.60	27.40	31.60	31.60	31.50	35.50	35.80	35.70																
	AMPS^	17.42	18.20	18.99	17.94	18.74	19.59	18.50	19.36	20.25	19.12	20.01	20.95	19.86	20.76	21.73	20.56	21.54	22.57	21.41	22.41	23.46	22.29	23.43	24.51																
	HI PR	223	239	256	233	250	268	245	262	281	259	278	297	276	295	315	293	312	333	312	333	354	333	357	379																
	LO PR	33	34	34	43	44	44	55	55	55	67	68	68	82	82	82	97	98	98	112	113	114	126	128	129																

† Total capacities are net (I.D. blower heat subtracted) system capacities based on 25' line set.
If additional tubing length and/or indoor unit is located above outdoor unit, a slight variation in capacity may occur.

^ System amps are total of indoor and outdoor amps.

COOLING Multiplying Factors for other Indoor Combinations

Indoor Model	Furnace Model	Capac. (MBh)	Power (AMPS)	Indoor Model	Furnace Model	Capac. (MBh)	Power (AMPS)	Indoor Model	Furnace Model	Capac. (MBh)	Power (AMPS)
N4H318											
> FS(M,U)4X18****		1.00	1.00	EL*24B****		0.96	1.00	EXX*24F****	MV12F19****	1.02	0.90
ED*4X18B**		0.99	0.99	EL*24B****	MV08B15****	0.98	0.90	FS(M,U)4X24****		1.01	1.01
ED*4X18B**	MV08B15****	1.01	0.91	EMH24F****		0.96	1.00	FEM4X18****		1.02	0.92
ED*4X24B**		1.02	1.00	EP*18B****		0.92	1.00	FEM4X24****		1.04	0.91
ED*4X24B**	MV08B15****	1.04	0.91	EP*18B****	MV08B15****	0.94	0.90	EBP18****		0.96	0.99
ED*4X24F**		1.02	1.00	EP*24B****		0.96	1.00	EBP24****		1.00	0.98
ED*4X24F**	MV12F19****	1.04	0.91	EP*24B****	MV08B15****	0.98	0.90	FWM18****		0.96	0.96
EMA4X24D**		1.02	1.00	EP*24F****		0.96	1.00	FWM24****		1.00	1.00
EHD4X24A**		1.02	0.99	EP*24F****	MV12F19****	0.98	0.90	EBXX18****		1.00	0.98
EHD4X24A**	MV08B15****	1.04	0.91	EPP024****		0.91	1.00	EBXX24****		1.01	0.98
EHD4X24A**	MV12F19****	1.04	0.91	EXX*24B****		1.01	0.99	EBV24****		1.04	0.93
EL*18B****		0.92	1.00	EXX*24B****	MV08B15****	1.03	0.90	EBV36****		1.03	0.99
EL*18B****	MV08B15****	0.94	0.90	EXX*24F****		1.01	0.99	FSA2X24****		1.01	1.01
N4H324											
> FS(M,U)4X24****		1.00	1.00	EHD4X24A**	MV20N26****	1.03	0.95	EP*30F****	MV12F19****	0.98	0.92
ED*4X24B**		1.01	1.01	EHD4X30A**		1.02	1.02	EXX*24B****		1.01	1.04
ED*4X24B**	*8MPV050	1.02	0.98	EHD4X30A**	*8MPV050	1.04	0.97	EXX*24B****	*8MPV050	1.02	0.98
ED*4X24B**	MV08B15****	1.04	0.96	EHD4X30A**	*9MPV050	1.04	0.97	EXX*24B****	MV08B15****	1.03	0.96
ED*4X24F**		1.01	1.01	EHD4X30A**	*9MPV075	1.04	0.97	EXX*24F****		1.01	1.04
ED*4X24F**	*9MPV050	1.02	0.96	EHD4X30A**	*9MPV100	1.04	0.97	EXX*24F****	*9MPV050	1.02	0.98
ED*4X24F**	*9MPV075	1.03	0.96	EHD4X30A**	MV08B15****	1.04	0.96	EXX*24F****	*9MPV075	1.02	0.98
ED*4X24F**	MV12F19****	1.04	0.96	EHD4X30A**	MV12F19****	1.04	0.93	EXX*24F****	MV12F19****	1.02	0.94
ED*4X30B**		1.02	1.02	EHD4X30A**	MV16J22****	1.05	0.95	FS(M,U)4X30****		1.02	1.02
ED*4X30B**	*8MPV050	1.04	0.97	EHD4X30A**	MV20N26****	1.05	0.95	FEM4X24****		1.02	0.96
ED*4X30B**	MV08B15****	1.04	0.96	EL*24B****	*8MPV050	0.96	0.98	FEM4X30****		1.04	0.96
ED*4X30F**		1.02	1.02	EL*24B****	MV08B15****	0.96	0.92	EBP24****		0.99	1.02
ED*4X30F**	*9MPV050	1.04	0.97	EL*30B****		0.96	1.03	EBP30****		1.00	1.00
ED*4X30F**	*9MPV075	1.04	0.97	EL*30B****	*8MPV050	0.96	0.96	FWM24****		0.99	1.07
ED*4X30F**	MV12F19****	1.05	0.95	EL*30B****	MV08B15****	0.97	0.94	FWM30****		1.00	1.03
EMA4X24D**		1.01	1.01	EMH30F****		0.96	1.03	EBXX18****		0.99	1.02
EHD4X24A**		1.01	1.01	EP*24B****	*8MPV050	0.96	0.98	EBXX24****		1.00	1.00
EHD4X24A**	*8MPV050	1.02	0.98	EP*24B****	MV08B15****	0.96	0.92	EL*24B****		0.94	1.03
EHD4X24A**	*8MPV075	1.02	0.96	EP*24F****	*9MPV050	0.95	0.95	EMH24F****		0.94	1.03
EHD4X24A**	*8MPV100	1.03	0.96	EP*24F****	*9MPV075	0.95	0.95	EP*24B****		0.94	1.03
EHD4X24A**	*8MPV125	1.03	0.96	EP*24F****	MV12F19****	0.96	0.93	EP*24F****		0.94	1.03

> Indicates Tested Indoor Model

- continued on next page -

COOLING Multiplying Factors for other Indoor Combinations (continued)

Indoor Model	Furnace Model	Capac. (MBh)	Power (AMPS)	Indoor Model	Furnace Model	Capac. (MBh)	Power (AMPS)	Indoor Model	Furnace Model	Capac. (MBh)	Power (AMPS)
EHD4X24A**	*9MPV050	1.02	0.98	EP*30B****		0.96	1.03	EPP024****		0.87	1.03
EHD4X24A**	*9MPV075	1.02	0.98	EP*30B****	*8MPV050	0.96	0.96	EPP030****		0.92	1.04
EHD4X24A**	*9MPV100	1.03	0.96	EP*30B****	MV08B15****	0.97	0.94	EXX*24F****	*8MPV075	1.03	0.99
EHD4X24A**	MV08B15****	1.04	0.96	EP*30F****		0.96	1.03	EBV24****		1.02	0.96
EHD4X24A**	MV12F19****	1.04	0.96	EP*30F****	*9MPV050	0.96	0.95	EBV36****		1.04	0.97
EHD4X24A**	MV16J22****	1.04	0.96	EP*30F****	*9MPV075	0.96	0.95	FSA2X24****		0.99	1.03
N4H330											
> FS(M,U)4X30****		1.00	1.00	EHD4X36A**	*8MPV075	1.02	0.95	EP*36F****	*9MPV050	0.97	0.99
ED*4X30B**		1.01	1.01	EHD4X36A**	*8MPV100	1.03	0.94	EP*36F****	*9MPV075	0.97	0.99
ED*4X30B**	*8MPV050	1.01	0.98	EHD4X36A**	*8MPV125	1.03	0.94	EP*36F****	MV12F19****	0.99	0.94
ED*4X30B**	MV08B15****	1.02	0.95	EHD4X36A**	*9MPV050	1.02	0.96	EP*36J****		0.97	1.04
ED*4X30F**		1.01	1.01	EHD4X36A**	*9MPV075	1.02	0.96	EP*36J****	*8MPV100	0.97	0.92
ED*4X30F**	*8MPV075	1.02	0.96	EHD4X36A**	*9MPV100	1.03	0.95	EP*36J****	*8MPV125	0.97	0.92
ED*4X30F**	*9MPV050	1.01	0.98	EHD4X36A**	*9MPV125	1.03	0.95	EP*36J****	*9MPV100	0.97	0.94
ED*4X30F**	*9MPV075	1.02	0.96	EHD4X36A**	MV08B15****	1.03	0.94	EP*36J****	MV16J22****	0.99	0.93
ED*4X30F**	MV12F19****	1.02	0.95	EHD4X36A**	MV12F19****	1.03	0.94	EPP036****		0.92	1.04
ED*4X36B**		1.01	1.01	EHD4X36A**	MV16J22****	1.03	0.94	EXX*36B****		1.01	1.01
ED*4X36B**	*8MPV050	1.02	0.99	EHD4X36A**	MV20N26****	1.03	0.92	EXX*36B****	*8MPV050	1.02	0.99
ED*4X36B**	MV08B15****	1.03	0.95	EL*30B****		0.93	1.00	EXX*36B****	MV08B15****	1.03	0.95
ED*4X36F**		1.01	1.01	EL*30B****	*8MPV050	0.93	1.00	EXX*36F****		1.01	1.01
ED*4X36F**	*8MPV075	1.02	0.95	EL*30B****	MV08B15****	0.94	0.96	EXX*36F****	*8MPV075	1.02	0.96
ED*4X36F**	*9MPV050	1.02	0.99	EL*36B****		0.97	1.04	EXX*36F****	*9MPV050	1.01	0.98
ED*4X36F**	*9MPV075	1.02	0.96	EL*36B****	*8MPV050	0.97	0.99	EXX*36F****	*9MPV075	1.01	0.98
ED*4X36F**	MV12F19****	1.03	0.94	EL*36B****	MV08B15****	0.98	0.95	EXX*36F****	MV12F19****	1.03	0.96
ED*4X36J**		1.01	1.01	EL*36F****		0.97	1.04	EXX*36J****		1.01	1.01
ED*4X36J**	*8MPV100	1.03	0.96	EL*36F****	*8MPV075	0.98	0.95	EXX*36J****	*8MPV100	1.02	0.95
ED*4X36J**	*8MPV125	1.03	0.94	EL*36F****	*9MPV050	0.97	0.99	EXX*36J****	*8MPV125	1.02	0.95
ED*4X36J**	*9MPV100	1.03	0.95	EL*36F****	*9MPV075	0.97	0.99	EXX*36J****	*9MPV100	1.02	0.96
ED*4X36J**	MV16J22****	1.03	0.94	EL*36F****	MV12F19****	0.99	0.94	EXX*36J****	MV16J22****	1.03	0.94
EMA4X36D**		1.01	1.01	EMH30F****		0.93	1.00	EHD4X30A**	MV16J22****	1.03	0.94
EHD4X30A**		1.01	1.01	EMH36F****		0.97	1.04	EPP030****		0.90	1.02
EHD4X30A**	*8MPV050	1.01	0.96	EP*30B****		0.93	1.00	FSA2X30****		0.99	1.00
EHD4X30A**	*8MPV075	1.02	0.96	EP*30B****	*8MPV050	0.93	1.00	FSA2X36****		1.01	1.02
EHD4X30A**	*8MPV100	1.03	0.97	EP*30B****	MV08B15****	0.94	0.96	FSU4X36****		1.01	1.01
EHD4X30A**	*8MPV125	1.03	0.95	EP*30F****		0.93	1.00	FEM4X30****		1.01	0.96
EHD4X30A**	*9MPV050	1.01	1.01	EP*30F****	*8MPV075	0.94	0.96	FEM4X36****		1.05	0.97
EHD4X30A**	*9MPV075	1.02	0.99	EP*30F****	*9MPV050	0.93	1.00	EBP30****		0.99	1.01
EHD4X30A**	*9MPV100	1.03	0.97	EP*30F****	*9MPV075	0.93	1.00	EBP36****		1.00	1.02

> Indicates Tested Indoor Model

COOLING Multiplying Factors for other Indoor Combinations (continued)

Indoor Model	Furnace Model	Capac. (MBh)	Power (AMPS)	Indoor Model	Furnace Model	Capac. (MBh)	Power (AMPS)	Indoor Model	Furnace Model	Capac. (MBh)	Power (AMPS)
EHD4X30A**	*9MPV125	1.03	0.95	EP*30F****	MV12F19****	0.95	0.92	FWM30****		0.99	1.01
EHD4X30A**	MV08B15****	1.02	0.95	EP*36B****		0.97	1.04	EBX36****		1.01	1.03
EHD4X30A**	MV12F19****	1.02	0.95	EP*36B****	*8MPV050	0.97	0.99	EBV36****		1.01	0.96
EHD4X30A**	MV20N26****	1.02	0.93	EP*36B****	MV08B15****	0.98	0.95	EBV48****		1.05	0.97
EHD4X36A**		1.01	1.01	EP*36F****		0.97	1.04	FSM4X36****		1.03	0.99
EHD4X36A**	*8MPV050	1.02	0.96	EP*36F****	*8MPV075	0.99	0.99				
N4H336											
> FS(M,U)4X42****		1.00	1.00	EHD4X42A**	*9MPV100	1.00	0.94	EP*36J****		0.94	1.01
ED*4X36B**		0.95	0.95	EHD4X42A**	*9MPV125	1.00	0.94	EP*36J****	*8MPV100	0.94	0.94
ED*4X36B**	MV08B15****	0.97	0.95	EHD4X42A**	MV08B15****	1.00	0.94	EXX*36B****		0.98	1.00
ED*4X36F**		0.98	0.98	EHD4X42A**	MV12F19****	1.01	0.94	EXX*36B****	*8MPV050	0.97	1.00
ED*4X36F**	*8MPV075	0.99	0.95	EHD4X42A**	MV16J22****	1.02	0.94	EXX*36F****	*8MPV075	0.99	0.99
ED*4X36F**	*9MPV075	0.98	0.98	EHD4X42A**	MV20N26****	1.02	0.94	EXX*36F****	*9MPV050	0.97	1.05
ED*4X36F**	MV12F19****	1.00	0.96	EL*36B****		0.92	0.99	EXX*36F****	*9MPV075	0.98	1.00
ED*4X36J**		0.98	0.98	EL*36B****	MV08B15****	0.94	0.97	EXX*36F****	MV12F19****	1.00	0.96
ED*4X36J**	*8MPV100	0.99	0.93	EL*36F****	*8MPV075	0.94	0.97	EXX*36J****		0.98	1.01
ED*4X36J**	*8MPV125	1.00	0.94	EL*42F****		0.96	0.99	EXX*36J****	*8MPV100	1.00	0.96
ED*4X36J**	*9MPV100	0.99	0.96	EL*42F****	*8MPV075	0.97	1.00	EXX*36J****	*8MPV125	1.00	0.96
ED*4X36J**	MV16J22****	1.01	0.95	EL*42F****	MV12F19****	0.98	0.95	EXX*36J****	*9MPV100	0.99	0.95
ED*4X42J**		0.99	0.99	EMH42F****		0.96	0.99	EXX*36J****	MV16J22****	1.01	0.94
ED*4X42J**	*8MPV100	1.01	0.94	EP*36B****		0.92	0.99	EXX*42F****		1.00	1.03
ED*4X42J**	*8MPV125	1.01	0.94	EP*36B****	MV08B15****	0.94	0.97	EXX*42F****	*8MPV075	1.01	0.99
ED*4X42J**	*9MPV100	1.00	0.96	EP*36F****	*8MPV075	0.94	0.97	EXX*42F****	*9MPV050	0.99	0.97
ED*4X42J**	MV16J22****	1.02	0.94	EP*36J****	*8MPV125	0.95	0.95	EXX*42F****	*9MPV075	0.99	0.98
ED*4X42L**		0.99	0.99	EP*36J****	*9MPV100	0.94	0.97	EXX*42F****	MV12F19****	1.01	0.94
ED*4X42L**	*9MPV125	1.01	0.97	EP*36J****	MV16J22****	0.96	0.92	EXX*42J****		1.00	1.03
EMA4X36D**		0.98	0.98	EP*42F****		0.96	0.99	EXX*42J****	*8MPV100	1.01	0.98
EHD4X36A**		0.98	0.98	EP*42F****	*8MPV075	0.97	1.00	EXX*42J****	*8MPV125	1.01	0.98
EHD4X36A**	*8MPV075	0.99	0.95	EP*42F****	MV12F19****	0.98	0.95	EXX*42J****	*9MPV100	1.01	0.99
EHD4X36A**	*8MPV100	0.99	0.96	EP*42J****		0.97	1.00	EXX*42J****	MV16J22****	1.02	0.96
EHD4X36A**	*8MPV125	1.00	0.94	EP*42J****	*8MPV125	0.96	0.99	FSU4X36****		0.98	1.01
EHD4X36A**	*9MPV075	0.98	0.96	EP*42J****	MV16J22****	0.98	0.98	FSM4X36****		1.01	1.01
EHD4X36A**	*9MPV100	0.99	0.96	EPP036****		0.87	0.99	FEM4X36****		1.02	0.96
EHD4X36A**	*9MPV125	0.99	0.93	EB*4X36B**	MV08B15****	0.99	0.98	FEM4X42****		1.02	0.96
EHD4X36A**	MV08B15****	1.00	0.96	EL*36F****		0.94	1.01	EBP36****		0.96	1.04
EHD4X36A**	MV12F19****	1.00	0.94	EL*36F****	*9MPV050	0.92	0.99	EBP42****		0.98	1.01
EHD4X36A**	MV16J22****	1.01	0.93	EL*36F****	*9MPV075	0.94	0.99	EBX36****		0.98	1.01

> Indicates Tested Indoor Model

COOLING Multiplying Factors for other Indoor Combinations (continued)

Indoor Model	Furnace Model	Capac. (MBh)	Power (AMPS)	Indoor Model	Furnace Model	Capac. (MBh)	Power (AMPS)	Indoor Model	Furnace Model	Capac. (MBh)	Power (AMPS)
EHD4X36A**	MV20N26****	1.01	0.93	EL*36F****	MV12F19****	0.95	0.95	EXX*36B****	MV08B15****	0.99	0.98
EHD4X42A**		0.99	0.99	EMH36F****		0.94	1.01	EXX*36F****		0.98	1.00
EHD4X42A**	*8MPV075	1.01	0.97	EP*36F****		0.94	1.01	EBV36****		0.99	0.96
EHD4X42A**	*8MPV100	1.01	0.94	EP*36F****	*9MPV050	0.92	0.99	EBV48****		1.02	0.96
EHD4X42A**	*8MPV125	1.01	0.94	EP*36F****	*9MPV075	0.94	0.99	FSA2X36****		0.98	1.00
EHD4X42A**	*9MPV075	0.99	0.96	EP*36F****	MV12F19****	0.95	0.94				
N4H342											
> FS(M,U)4X42****		1.00	1.00	EHD4X42A**	MV16J22****	1.01	0.91	EP*48L****	*9MPV125	1.00	0.97
ED*4X42J**		0.99	0.99	EHD4X42A**	MV20N26****	1.01	0.91	EP*48N****		0.99	1.04
ED*4X42J**	*8MPV100	1.01	0.95	EHD4X48A**		1.01	0.98	EXX*42F****		0.99	0.96
ED*4X42J**	*8MPV125	1.01	0.95	EHD4X48A**	*8MPV075	1.02	0.96	EXX*42F****	*8MPV075	1.00	0.97
ED*4X42J**	*9MPV100	1.00	0.95	EHD4X48A**	*8MPV100	1.02	0.96	EXX*42J****		0.99	0.96
ED*4X42J**	MV16J22****	1.01	0.92	EHD4X48A**	*8MPV125	1.02	0.94	EXX*42J****	*8MPV100	1.01	0.97
ED*4X42L**		0.99	0.99	EHD4X48A**	*9MPV075	1.01	0.97	EXX*42J****	*8MPV125	1.00	0.94
ED*4X42L**	*9MPV125	1.00	0.94	EHD4X48A**	*9MPV100	1.01	0.95	EXX*42J****	*9MPV100	1.00	0.95
ED*4X48F**		1.02	1.00	EHD4X48A**	*9MPV125	1.02	0.94	EXX*42J****	MV16J22****	1.01	0.92
ED*4X48F**	*8MPV075	1.02	0.98	EHD4X48A**	MV16J22****	1.04	0.93	EXX*48J****		1.00	0.97
ED*4X48F**	*9MPV075	1.01	0.97	EHD4X48A**	MV20N26****	1.02	0.92	EXX*48J****	*9MPV125	1.00	0.94
ED*4X48J**		1.01	0.98	EL*42F****		0.94	0.99	EXX*48L****		1.00	0.97
ED*4X48J**	*8MPV100	1.02	0.96	EL*48F****		0.98	1.02	EXX*48L****	*9MPV125	1.00	0.94
ED*4X48J**	*8MPV125	1.02	0.96	EMH42F****		0.94	0.99	EXX*48N****		1.00	0.97
ED*4X48J**	*9MPV100	1.01	0.95	EMH48F****		0.98	0.98	EXX*48N****	MV20N26****	1.01	0.91
ED*4X48J**	MV16J22****	1.04	0.93	EP*42F****		0.94	0.99	FS(M,U)4X48****		1.02	1.00
ED*4X48L**		1.01	0.98	EP*42J****		0.95	1.00	FSM4X36****		1.01	0.98
ED*4X48L**	*9MPV125	1.02	0.96	EP*42J****	*8MPV125	0.95	1.00	FEM4X42****		1.02	0.96
EMA4X48D**		1.00	0.97	EP*42J****	MV16J22****	0.96	0.96	FEM4X48****		1.05	0.94
EHD4X42A**		0.99	0.96	EP*48F****		0.98	1.02	EBP42****		0.99	1.04
EHD4X42A**	*8MPV075	1.01	0.97	EP*48F****	*8MPV075	0.98	1.02	EBP48****		1.00	1.05
EHD4X42A**	*8MPV100	1.01	0.95	EP*48J****		0.99	1.04	EBXX48****		1.02	1.00
EHD4X42A**	*8MPV125	1.01	0.92	EP*48J****	*8MPV100	1.00	0.95	EP*48N****	MV20N26****	0.99	0.90
EHD4X42A**	*9MPV075	1.00	0.95	EP*48J****	*8MPV125	1.00	0.95	EP*48J****	MV16J22****	0.99	0.90
EHD4X42A**	*9MPV100	1.00	0.94	EP*48J****	*9MPV100	0.99	0.96	EBV48****		1.02	0.96
EHD4X42A**	*9MPV125	1.00	0.94	EP*48L****		0.99	1.04	EBV60****		1.05	0.94
N4H348											
> FS(M,U)4X48****		1.00	1.00	EHD4X60A**	*8MPV125	1.02	0.96	EP*60L****		0.98	0.98
ED*4X48F**		0.97	0.97	EHD4X60A**	*9MPV100	1.01	0.97	EP*60L****	*9MPV125	0.98	0.96

> Indicates Tested Indoor Model

- continued on next page -

COOLING Multiplying Factors for other Indoor Combinations (continued)

Indoor Model	Furnace Model	Capac. (MBh)	Power (AMPS)	Indoor Model	Furnace Model	Capac. (MBh)	Power (AMPS)	Indoor Model	Furnace Model	Capac. (MBh)	Power (AMPS)
ED*4X48J**		0.99	0.99	EHD4X60A**	*9MPV125	1.01	0.97	EP*60N****		0.98	0.98
ED*4X48J**	*8MPV100	0.99	0.97	EHD4X60A**	MV16J22****	1.03	0.95	EP*60N****	MV20N26****	0.99	0.95
ED*4X48J**	*8MPV125	0.99	0.95	EHD4X60A**	MV20N26****	1.03	0.95	EXX*48J****		0.97	0.97
ED*4X48J**	MV16J22****	1.00	0.94	EL*48F****		0.92	0.92	EXX*48J****	*9MPV125	0.97	0.95
ED*4X48L**		0.99	0.99	EL*60J****		0.98	0.98	EXX*48L****		0.97	0.97
ED*4X48L**	*9MPV125	0.99	0.97	EL*60J****	*8MPV100	0.98	0.96	EXX*48L****	*9MPV125	0.97	0.95
ED*4X60J**		1.01	1.01	EL*60J****	*8MPV125	0.98	0.96	EXX*48N****		0.97	0.97
ED*4X60J**	*8MPV100	1.02	0.98	EL*60J****	MV16J22****	0.99	0.95	EXX*48N****	MV20N26****	0.99	0.95
ED*4X60J**	*8MPV125	1.02	0.96	EMH48F****		0.94	0.94				
ED*4X60J**	*9MPV100	1.01	0.97	EP*48F****		0.92	0.92				
ED*4X60J**	MV16J22****	1.03	0.95	EP*48J****		0.95	0.95				
ED*4X60L**		1.01	1.01	EP*48J****	*8MPV100	0.96	0.96				
ED*4X60L**	*9MPV125	1.01	0.97	EP*48J****	*8MPV125	0.96	0.94	FS(M,U)4X60****		1.02	1.00
EMA4X48D**		0.97	0.97	EP*48J****	MV16J22****	0.97	0.95	FEM4X48****		1.02	0.98
EHD4X48A**		0.99	0.99	EP*48L****		0.95	0.95	FEM4X60****		1.03	0.95
EHD4X48A**	*8MPV100	0.99	0.97	EP*48L****	*9MPV125	0.96	0.94	EBP48****		0.98	0.98
EHD4X48A**	*8MPV125	0.99	0.95	EP*48N****		0.95	0.95	EBP60****		1.00	1.00
EHD4X48A**	*9MPV125	0.99	0.95	EP*48N****	MV20N26****	0.97	0.93	EBXX48****		1.00	0.98
EHD4X48A**	MV16J22****	1.00	0.94	EP*60J****		0.98	0.98	EBXX60****		1.02	1.00
EHD4X48A**	MV20N26****	1.00	0.94	EP*60J****	*8MPV100	0.98	0.96	EBV48****		1.02	0.98
EHD4X60A**		1.01	1.01	EP*60J****	*8MPV125	0.98	0.96	EBV60****		1.03	0.95
EHD4X60A**	*8MPV100	1.02	0.98	EP*60J****	MV16J22****	0.99	0.95				
N4H360											
> FS(M,U)4X60****		1.00	1.00	EL*60J****	MV16J22****	0.96	0.94	EXX*60L****		0.99	0.99
ED*4X60J**		0.99	0.99	EP*60J****		0.94	0.94	EXX*60N****		0.99	0.99
ED*4X60J**	MV16J22****	1.01	0.97	EP*60J****	*8MPV125	0.94	0.94	EXX*60N****	MV20N26****	1.01	0.95
ED*4X60L**		1.01	1.01	EP*60J****	MV16J22****	0.96	0.94	FEM4X60****		1.01	0.91
EHD4X60A**		1.01	1.01	EP*60L****		0.94	0.94	EBP60****		0.98	1.01
EHD4X60A**	MV16J22****	1.01	0.95	EP*60N****		0.94	0.94	EBXX60****		1.01	0.99
EHD4X60A**	MV20N26****	1.02	0.98	EP*60N****	MV20N26****	0.97	0.99	EBV60****		1.01	0.99
EL*60J****		0.94	0.94								

> Indicates Tested Indoor Model

HEATING Multiplying Factors for other Indoor Combinations

Indoor Model	Furnace Model	Capac. (MBh)	Power (AMPS)	Indoor Model	Furnace Model	Capac. (MBh)	Power (AMPS)	Indoor Model	Furnace Model	Capac. (MBh)	Power (AMPS)
N4H318											
> FS(M,U)4X18****		1.00	1.00	EL*24B****		0.98	1.02	EXX*24F****	MV12F19****	0.93	0.89
ED*4X18B**		0.99	1.01	EL*24B****	MV08B15****	0.96	0.94	FS(M,U)4X24****		1.00	0.99
ED*4X18B**	MV08B15****	0.96	0.92	EMH24F****		0.98	1.02	FEM4X18****		0.98	0.92
ED*4X24B**		1.00	0.97	EP*18B****		0.97	1.08	FEM4X24****		0.97	0.89
ED*4X24B**	MV08B15****	0.97	0.88	EP*18B****	MV08B15****	0.93	1.00	EBP18****		0.98	1.04
ED*4X24F**		1.00	0.97	EP*24B****		0.98	1.02	EBP24****		1.00	0.99
ED*4X24F**	MV12F19****	0.97	0.87	EP*24B****	MV08B15****	0.96	0.94	FWM18****		0.97	1.01
EMA4X24D**		1.00	0.95	EP*24F****		0.98	1.02	FWM24****		1.00	1.00
EHD4X24A**		0.99	0.95	EP*24F****	MV12F19****	0.96	0.94	EBX18****		1.00	0.99
EHD4X24A**	MV08B15****	0.96	0.88	EPP024****		0.96	1.11	EBX24****		0.99	0.97
EHD4X24A**	MV12F19****	0.97	0.85	EXX*24B****		0.96	0.96	EBV24****		0.96	0.87
EL*18B****		0.97	1.08	EXX*24B****	MV08B15****	0.93	0.88	EBV36****		0.95	0.94
EL*18B****	MV08B15****	0.93	1.00	EXX*24F****		0.96	0.96	FSA2X24****		0.99	0.97
N4H324											
> FS(M,U)4X24****		1.00	1.00	EHD4X24A**	MV20N26****	0.98	0.89	EP*30F****	MV12F19****	0.98	0.95
ED*4X24B**		1.02	1.00	EHD4X30A**		0.97	0.96	EXX*24B****		0.98	0.99
ED*4X24B**	*8MPV050	1.00	0.95	EHD4X30A**	*8MPV050	0.95	0.91	EXX*24B****	*8MPV050	0.96	0.94
ED*4X24B**	MV08B15****	0.99	0.91	EHD4X30A**	*9MPV050	0.96	0.92	EXX*24B****	MV08B15****	0.95	0.91
ED*4X24F**		1.02	1.00	EHD4X30A**	*9MPV075	0.96	0.92	EXX*24F****		0.98	0.99
ED*4X24F**	*9MPV050	1.00	0.94	EHD4X30A**	*9MPV100	0.94	0.88	EXX*24F****	*9MPV050	0.96	0.94
ED*4X24F**	*9MPV075	1.00	0.93	EHD4X30A**	MV08B15****	0.95	0.89	EXX*24F****	*9MPV075	0.96	0.94
ED*4X24F**	MV12F19****	0.99	0.91	EHD4X30A**	MV12F19****	0.94	0.87	EXX*24F****	MV12F19****	0.95	0.91
ED*4X30B**		0.98	0.97	EHD4X30A**	MV16J22****	0.93	0.85	FS(M,U)4X30****		1.00	0.97
ED*4X30B**	*8MPV050	0.97	0.92	EHD4X30A**	MV20N26****	0.94	0.87	FEM4X24****		0.99	0.94
ED*4X30B**	MV08B15****	0.96	0.90	EL*24B****	*8MPV050	0.98	1.02	FEM4X30****		0.98	0.91
ED*4X30F**		0.98	0.97	EL*24B****	MV08B15****	0.97	0.99	EBP24****		1.01	1.02
ED*4X30F**	*9MPV050	0.96	0.91	EL*30B****		1.00	1.04	EBP30****		1.01	1.00
ED*4X30F**	*9MPV075	0.96	0.91	EL*30B****	*8MPV050	0.99	1.00	FWM24****		1.02	1.04
ED*4X30F**	MV12F19****	0.95	0.87	EL*30B****	MV08B15****	0.98	0.98	FWM30****		1.01	1.01
EMA4X24D**		1.02	0.98	EMH30F****		1.00	1.04	EBX18****		1.01	1.02
EHD4X24A**		1.00	0.96	EP*24B****	*8MPV050	0.98	1.02	EBX24****		1.01	1.00
EHD4X24A**	*8MPV050	0.99	0.92	EP*24B****	MV08B15****	0.97	0.99	EL*24B****		0.99	1.08
EHD4X24A**	*8MPV075	0.99	0.91	EP*24F****	*9MPV050	0.98	1.02	EMH24F****		0.99	1.08
EHD4X24A**	*8MPV100	0.98	0.89	EP*24F****	*9MPV075	0.98	1.03	EP*24B****		0.99	1.08
EHD4X24A**	*8MPV125	0.98	0.89	EP*24F****	MV12F19****	0.97	0.98	EP*24F****		0.99	1.08

> Indicates Tested Indoor Model

- continued on next page -

HEATING Multiplying Factors for other Indoor Combinations (continued)

Indoor Model	Furnace Model	Capac. (MBh)	Power (AMPS)	Indoor Model	Furnace Model	Capac. (MBh)	Power (AMPS)	Indoor Model	Furnace Model	Capac. (MBh)	Power (AMPS)
EHD4X24A**	*9MPV050	0.99	0.92	EP*30B****		1.00	1.04	EPP024****		0.95	1.18
EHD4X24A**	*9MPV075	0.99	0.93	EP*30B****	*8MPV050	0.99	1.00	EPP030****		0.98	1.09
EHD4X24A**	*9MPV100	0.98	0.90	EP*30B****	MV08B15****	0.98	0.98	EXX*24F****	*8MPV075	0.96	0.92
EHD4X24A**	MV08B15****	0.98	0.89	EP*30F****		1.00	1.04	EBV24****		0.96	0.89
EHD4X24A**	MV12F19****	0.98	0.88	EP*30F****	*9MPV050	0.98	0.99	EBV36****		0.92	0.88
EHD4X24A**	MV16J22****	0.98	0.88	EP*30F****	*9MPV075	0.98	1.00	FSA2X24****		0.98	1.00
N4H330											
> FS(M,U)4X30****		1.00	1.00	EHD4X36A**	*8MPV075	0.99	0.92	EP*36F****	*9MPV050	0.99	1.01
ED*4X30B**		1.01	1.00	EHD4X36A**	*8MPV100	0.99	0.90	EP*36F****	*9MPV075	0.99	1.00
ED*4X30B**	*8MPV050	1.00	0.98	EHD4X36A**	*8MPV125	0.99	0.91	EP*36F****	MV12F19****	0.98	0.95
ED*4X30B**	MV08B15****	0.99	0.95	EHD4X36A**	*9MPV050	1.00	0.95	EP*36J****		1.00	1.03
ED*4X30F**		1.01	1.00	EHD4X36A**	*9MPV075	1.00	0.93	EP*36J****	*8MPV100	0.97	0.98
ED*4X30F**	*8MPV075	0.99	0.96	EHD4X36A**	*9MPV100	0.99	0.92	EP*36J****	*8MPV125	0.97	0.97
ED*4X30F**	*9MPV050	0.99	0.98	EHD4X36A**	*9MPV125	0.99	0.91	EP*36J****	*9MPV100	0.97	0.98
ED*4X30F**	*9MPV075	1.00	0.98	EHD4X36A**	MV08B15****	0.99	0.90	EP*36****	MV16J22****	0.97	0.95
ED*4X30F**	MV12F19****	0.97	0.94	EHD4X36A**	MV12F19****	0.98	0.90	EPP036****		0.97	1.08
ED*4X36B**		1.01	1.00	EHD4X36A**	MV16J22****	0.98	0.87	EXX*36B****		1.01	0.98
ED*4X36B**	*8MPV050	1.00	0.97	EHD4X36A**	MV20N26****	0.98	0.87	EXX*36B****	*8MPV050	1.01	0.96
ED*4X36B**	MV08B15****	0.99	0.95	EL*30B****		0.98	1.06	EXX*36B****	MV08B15****	1.00	0.94
ED*4X36F**		1.01	1.00	EL*30B****	*8MPV050	0.97	1.05	EXX*36F****		1.01	0.98
ED*4X36F**	*8MPV075	0.99	0.95	EL*30B****	MV08B15****	0.96	1.02	EXX*36F****	*8MPV075	1.00	0.95
ED*4X36F**	*9MPV050	1.00	0.98	EL*36B****		1.00	1.03	EXX*36F****	*9MPV050	1.00	0.98
ED*4X36F**	*9MPV075	1.00	0.97	EL*36B****	*8MPV050	0.99	1.00	EXX*36F****	*9MPV075	1.00	0.97
ED*4X36F**	MV12F19****	0.98	0.93	EL*36B****	MV08B15****	0.98	0.98	EXX*36F****	MV12F19****	1.00	0.92
ED*4X36J**		1.01	1.00	EL*36F****		1.00	1.03	EXX*36J****		1.01	0.98
ED*4X36J**	*8MPV100	0.99	0.93	EL*36F****	*8MPV075	0.98	0.98	EXX*36J****	*8MPV100	0.99	0.93
ED*4X36J**	*8MPV125	0.99	0.93	EL*36F****	*9MPV050	0.99	1.01	EXX*36J****	*8MPV125	0.99	0.94
ED*4X36J**	*9MPV100	0.99	0.94	EL*36F****	*9MPV075	0.99	1.00	EXX*36J****	*9MPV100	0.99	0.94
ED*4X36J**	MV16J22****	0.98	0.92	EL*36F****	MV12F19****	0.98	0.95	EXX*36J****	MV16J22****	0.99	0.90
EMA4X36D**		1.01	1.00	EMH30F****		0.98	1.06	EHD4X30A**	MV16J22****	1.04	0.98
EHD4X30A**		1.01	0.99	EMH36F****		1.00	1.03	EPP030****		1.02	1.18
EHD4X30A**	*8MPV050	1.00	0.97	EP*30B****		0.98	1.06	FSA2X30****		1.05	1.06
EHD4X30A**	*8MPV075	0.99	0.96	EP*30B****	*8MPV050	0.97	1.05	FSA2X36****		1.06	1.05
EHD4X30A**	*8MPV100	0.99	0.94	EP*30B****	MV08B15****	0.96	1.02	FSU4X36****		1.01	1.01
EHD4X30A**	*8MPV125	0.99	0.93	EP*30F****		0.98	1.06	FEM4X30****		0.99	0.95
EHD4X30A**	*9MPV050	0.99	0.97	EP*30F****	*8MPV075	0.97	1.02	FEM4X36****		1.01	0.93
EHD4X30A**	*9MPV075	1.00	0.97	EP*30F****	*9MPV050	0.97	1.05	EBP30****		0.99	1.02
EHD4X30A**	*9MPV100	1.00	0.95	EP*30F****	*9MPV075	0.97	1.04	EBP36****		1.01	1.03

> Indicates Tested Indoor Model

HEATING Multiplying Factors for other Indoor Combinations (continued)

Indoor Model	Furnace Model	Capac. (MBh)	Power (AMPS)	Indoor Model	Furnace Model	Capac. (MBh)	Power (AMPS)	Indoor Model	Furnace Model	Capac. (MBh)	Power (AMPS)
EHD4X30A**	*9MPV125	0.99	0.95	EP*30F****	MV12F19****	0.97	1.00	FWM30****		1.00	1.02
EHD4X30A**	MV08B15****	0.99	0.94	EP*36B****		1.00	1.03	EBXX36****		1.01	1.01
EHD4X30A**	MV12F19****	0.99	0.92	EP*36B****	*8MPV050	0.99	1.00	EBV36****		0.99	0.95
EHD4X30A**	MV20N26****	0.98	0.92	EP*36B****	MV08B15****	0.98	0.98	EBV48****		1.01	0.91
EHD4X36A**		1.01	0.97	EP*36F****		1.00	1.03	FSM4X36****		0.94	0.90
EHD4X36A**	*8MPV050	0.99	0.95	EP*36F****	*8MPV075	0.99	0.98				
N4H336											
> FS(M,U)4X42****		1.00	1.00	EHD4X42A**	*9MPV100	0.98	0.95	EP*36J****		0.98	1.00
ED*4X36B**		0.97	1.01	EHD4X42A**	*9MPV125	0.98	1.01	EP*36J****	*8MPV100	0.96	1.00
ED*4X36B**	MV08B15****	0.94	0.97	EHD4X42A**	MV08B15****	0.98	0.97	EXX*36B****		0.99	1.01
ED*4X36F**		0.99	1.00	EHD4X42A**	MV12F19****	0.98	0.95	EXX*36B****	*8MPV050	0.98	1.02
ED*4X36F**	*8MPV075	0.98	1.03	EHD4X42A**	MV16J22****	0.98	0.92	EXX*36F****	*8MPV075	0.99	0.99
ED*4X36F**	*9MPV075	0.99	1.02	EHD4X42A**	MV20N26****	0.98	0.92	EXX*36F****	*9MPV050	1.01	1.04
ED*4X36F**	MV12F19****	0.97	0.96	EL*36B****		0.97	0.95	EXX*36F****	*9MPV075	0.99	1.01
ED*4X36J**		0.99	1.02	EL*36B****	MV08B15****	0.97	0.94	EXX*36F****	MV12F19****	0.99	0.96
ED*4X36J**	*8MPV100	0.97	0.96	EL*36F****	*8MPV075	0.97	0.92	EXX*36J****		1.00	1.01
ED*4X36J**	*8MPV125	0.97	0.96	EL*42F****		0.99	0.94	EXX*36J****	*8MPV100	0.99	0.96
ED*4X36J**	*9MPV100	0.98	0.98	EL*42F****	*8MPV075	0.99	0.93	EXX*36J****	*8MPV125	0.99	0.95
ED*4X36J**	MV16J22****	0.98	0.93	EL*42F****	MV12F19****	0.98	0.90	EXX*36J****	*9MPV100	0.98	0.97
ED*4X42J**		1.00	1.01	EMH42F****		0.99	0.91	EXX*36J****	MV16J22****	0.98	0.92
ED*4X42J**	*8MPV100	0.98	0.95	EP*36B****		0.96	0.94	EXX*42F****		0.99	0.98
ED*4X42J**	*8MPV125	0.98	0.95	EP*36B****	MV08B15****	0.97	0.92	EXX*42F****	*8MPV075	0.99	0.96
ED*4X42J**	*9MPV100	0.98	0.97	EP*36F****	*8MPV075	0.97	0.90	EXX*42F****	*9MPV050	0.98	0.99
ED*4X42J**	MV16J22****	0.98	0.92	EP*36J****	*8MPV125	0.97	0.90	EXX*42F****	*9MPV075	0.98	0.97
ED*4X42L**		0.94	0.95	EP*36J****	*9MPV100	0.97	0.93	EXX*42F****	MV12F19****	0.97	0.93
ED*4X42L**	*9MPV125	0.98	0.95	EP*36J****	MV16J22****	0.97	0.92	EXX*42J****		0.99	0.97
EMA4X36D**		0.99	1.04	EP*42F****		0.99	0.93	EXX*42J****	*8MPV100	0.98	0.93
EHD4X36A**		0.99	1.00	EP*42F****	*8MPV075	0.99	0.93	EXX*42J****	*8MPV125	0.98	0.93
EHD4X36A**	*8MPV075	0.98	1.01	EP*42F****	MV12F19****	0.98	0.91	EXX*42J****	*9MPV100	0.99	0.96
EHD4X36A**	*8MPV100	0.98	0.99	EP*42J****		0.99	0.90	EXX*42J****	MV16J22****	0.97	0.90
EHD4X36A**	*8MPV125	0.98	1.01	EP*42J****	*8MPV125	0.97	0.88	FSU4X36****		1.00	1.04
EHD4X36A**	*9MPV075	0.99	0.98	EP*42J****	MV16J22****	0.99	1.10	FSM4X36****		1.00	0.99
EHD4X36A**	*9MPV100	0.98	1.01	EPP036****		0.94	1.00	FEM4X36****		0.98	0.94
EHD4X36A**	*9MPV125	0.98	0.97	EB*4X36B**	MV08B15****	0.98	1.04	FEM4X42****		0.98	0.93
EHD4X36A**	MV08B15****	0.98	0.97	EL*36F****		0.98	1.02	EBP36****		0.99	1.07
EHD4X36A**	MV12F19****	0.97	0.97	EL*36F****	*9MPV050	0.97	0.98	EBP42****		0.99	1.04
EHD4X36A**	MV16J22****	0.97	0.93	EL*36F****	*9MPV075	0.97	0.96	EBXX36****		0.99	1.04

> Indicates Tested Indoor Model

HEATING Multiplying Factors for other Indoor Combinations (continued)

Indoor Model	Furnace Model	Capac. (MBh)	Power (AMPS)	Indoor Model	Furnace Model	Capac. (MBh)	Power (AMPS)	Indoor Model	Furnace Model	Capac. (MBh)	Power (AMPS)
EHD4X36A**	MV20N26****	0.97	0.98	EL*36F****	MV12F19****	0.96	1.00	EXX*36B****	MV08B15****	0.99	0.97
EHD4X42A**		1.00	0.98	EMH36F****		0.98	1.09	EXX*36F****		0.99	1.01
EHD4X42A**	*8MPV075	0.98	0.95	EP*36F****		0.98	1.04	EBV36****		0.97	0.97
EHD4X42A**	*8MPV100	0.98	0.96	EP*36F****	*9MPV050	0.97	1.02	EBV48****		0.94	0.89
EHD4X42A**	*8MPV125	0.98	0.91	EP*36F****	*9MPV075	0.97	1.00	FSA2X36****		0.97	0.99
EHD4X42A**	*9MPV075	0.98	0.95	EP*36F****	MV12F19****	0.96	1.02				
N4H342											
> FS(M,U)4X42****		1.00	1.00	EHD4X42A**	MV16J22****	1.00	0.91	EP*48L****	*9MPV125	1.00	0.98
ED*4X42J**		1.01	1.02	EHD4X42A**	MV20N26****	0.99	0.92	EP*48N****		1.00	0.99
ED*4X42J**	*8MPV100	1.01	0.99	EHD4X48A**		1.00	0.97	EXX*42F****		1.00	1.01
ED*4X42J**	*8MPV125	1.00	0.97	EHD4X48A**	*8MPV075	0.99	0.95	EXX*42F****	*8MPV075	1.00	0.99
ED*4X42J**	*9MPV100	1.00	1.00	EHD4X48A**	*8MPV100	0.99	0.92	EXX*42J****		1.00	1.01
ED*4X42J**	MV16J22****	1.00	0.95	EHD4X48A**	*8MPV125	0.99	0.92	EXX*42J****	*8MPV100	1.00	0.97
ED*4X42L**		1.01	1.02	EHD4X48A**	*9MPV075	0.99	0.97	EXX*42J****	*8MPV125	1.00	0.96
ED*4X42L**	*9MPV125	1.00	0.99	EHD4X48A**	*9MPV100	0.99	0.94	EXX*42J****	*9MPV100	1.00	0.98
ED*4X48F**		0.98	0.95	EHD4X48A**	*9MPV125	0.99	0.93	EXX*42J****	MV16J22****	0.99	0.93
ED*4X48F**	*8MPV075	0.98	0.95	EHD4X48A**	MV16J22****	0.98	0.89	EXX*48J****		0.99	0.97
ED*4X48F**	*9MPV075	0.98	0.96	EHD4X48A**	MV20N26****	0.98	0.90	EXX*48J****	*9MPV125	0.98	0.94
ED*4X48J**		1.00	0.98	EL*42F****		0.99	1.07	EXX*48L****		0.99	0.97
ED*4X48J**	*8MPV100	0.99	0.94	EL*48F****		1.00	1.02	EXX*48L****	*9MPV125	0.98	0.94
ED*4X48J**	*8MPV125	0.99	0.93	EMH42F****		0.98	1.06	EXX*48N****		0.99	0.97
ED*4X48J**	*9MPV100	0.99	0.95	EMH48F****		1.00	1.02	EXX*48N****	MV20N26****	0.96	0.91
ED*4X48J**	MV16J22****	0.98	0.90	EP*42F****		0.98	1.06	FS(M,U)4X48****		0.98	0.97
ED*4X48L**		1.00	0.98	EP*42J****		0.99	1.05	FSM4X36****		1.01	1.01
ED*4X48L**	*9MPV125	0.99	0.94	EP*42J****	*8MPV125	0.99	1.05	FEM4X42****		1.00	0.96
EMA4X48D**		1.00	0.99	EP*42J****	MV16J22****	0.99	1.03	FEM4X48****		0.95	0.89
EHD4X42A**		1.01	0.98	EP*48F****		1.00	1.02	EBP42****		1.01	1.07
EHD4X42A**	*8MPV075	1.01	0.98	EP*48F****	*8MPV075	1.00	1.02	EBP48****		1.01	1.01
EHD4X42A**	*8MPV100	1.01	0.95	EP*48J****		1.00	1.00	EBX48****		0.98	0.98
EHD4X42A**	*8MPV125	1.00	0.94	EP*48J****	*8MPV100	0.99	0.96	EP*48N****	MV20N26****	0.98	0.94
EHD4X42A**	*9MPV075	1.00	0.99	EP*48J****	*8MPV125	0.99	0.96	EP*48J****	MV16J22****	0.98	0.94
EHD4X42A**	*9MPV100	1.00	0.96	EP*48J****	*9MPV100	0.99	1.35	EBV48****		0.96	0.94
EHD4X42A**	*9MPV125	1.00	0.95	EP*48L****		1.00	1.00	EBV60****		0.93	0.90
N4H348											
> FS(M,U)4X48****		1.00	1.00	EHD4X60A**	*8MPV125	0.91	0.87	EP*60L****		1.01	0.99
ED*4X48F**		0.99	0.97	EHD4X60A**	*9MPV100	0.93	0.90	EP*60L****	*9MPV125	1.00	0.97

> Indicates Tested Indoor Model

- continued on next page -

HEATING Multiplying Factors for other Indoor Combinations (continued)

Indoor Model	Furnace Model	Capac. (MBh)	Power (AMPS)	Indoor Model	Furnace Model	Capac. (MBh)	Power (AMPS)	Indoor Model	Furnace Model	Capac. (MBh)	Power (AMPS)
ED*4X48J**		1.01	0.99	EHD4X60A**	*9MPV125	0.93	0.89	EP*60N****		1.01	0.99
ED*4X48J**	*8MPV100	1.01	0.98	EHD4X60A**	MV16J22****	0.89	0.84	EP*60N****	MV20N26****	0.99	0.93
ED*4X48J**	*8MPV125	1.00	0.96	EHD4X60A**	MV20N26****	0.89	0.84	EXX*48J****		1.00	0.99
ED*4X48J**	MV16J22****	1.00	0.94	EL*48F****		0.99	1.06	EXX*48J****	*9MPV125	1.00	0.98
ED*4X48L**		1.01	0.99	EL*60J****		1.00	0.98	EXX*48L****		1.00	0.99
ED*4X48L**	*9MPV125	1.00	0.97	EL*60J****	*8MPV100	1.00	0.97	EXX*48L****	*9MPV125	1.00	0.98
ED*4X60J**		0.92	0.94	EL*60J****	*8MPV125	1.00	0.96	EXX*48N****		1.00	0.99
ED*4X60J**	*8MPV100	0.91	0.93	EL*60J****	MV16J22****	0.99	0.93	EXX*48N****	MV20N26****	0.99	0.94
ED*4X60J**	*8MPV125	0.91	0.91	EMH48F****		0.99	1.06				
ED*4X60J**	*9MPV100	0.93	0.95	EP*48F****		0.99	1.06				
ED*4X60J**	MV16J22****	0.89	0.88	EP*48J****		1.00	1.03				
ED*4X60L**		0.92	0.94	EP*48J****	*8MPV100	1.01	1.01				
ED*4X60L**	*9MPV125	0.93	0.93	EP*48J****	*8MPV125	1.00	1.00	FS(M,U)4X60****		0.94	0.95
EMA4X48D**		0.99	1.02	EP*48J****	MV16J22****	1.00	0.97	FEM4X48****		0.99	0.94
EHD4X48A**		1.00	0.97	EP*48L****		1.00	1.03	FEM4X60****		0.92	0.88
EHD4X48A**	*8MPV100	1.01	0.97	EP*48L****	*9MPV125	1.00	1.01	EBP48****		1.02	1.04
EHD4X48A**	*8MPV125	1.00	0.95	EP*48N****		1.00	1.03	EBP60****		1.01	1.02
EHD4X48A**	*9MPV125	1.00	0.97	EP*48N****	MV20N26****	1.00	0.97	EBX48****		1.00	0.99
EHD4X48A**	MV16J22****	1.00	0.93	EP*60J****		1.01	0.99	EBX60****		0.94	0.95
EHD4X48A**	MV20N26****	1.00	0.93	EP*60J****	*8MPV100	1.00	0.97	EBV48****		0.99	0.95
EHD4X60A**		0.92	0.90	EP*60J****	*8MPV125	1.00	0.96	EBV60****		0.92	0.89
EHD4X60A**	*8MPV100	0.91	0.88	EP*60J****	MV16J22****	0.99	0.93				
N4H360											
> FS(M,U)4X60****		1.00	1.00	EL*60J****	MV16J22****	0.98	0.99	EXX*60L****		0.98	0.99
ED*4X60J**		0.98	0.99	EP*60J****		0.98	1.03	EXX*60N****		0.98	0.99
ED*4X60J**	MV16J22****	0.98	0.96	EP*60J****	*8MPV125	0.98	1.02	EXX*60N****	MV20N26****	0.98	0.95
ED*4X60L**		1.00	0.99	EP*60J****	MV16J22****	0.98	0.99	FEM4X60****		0.98	0.95
EHD4X60A**		1.00	0.99	EP*60L****		0.98	1.03	EBP60****		1.00	1.05
EHD4X60A**	MV16J22****	0.98	0.96	EP*60N****		0.98	1.02	EBX60****		1.01	1.00
EHD4X60A**	MV20N26****	1.01	0.98	EP*60N****	MV20N26****	0.99	1.01	EBV60****		1.00	0.99
EL*60J****		0.98	1.03								

> Indicates Tested Indoor Model

NOTE: This illustration is for reference only. Your unit may differ in appearance or may not include all components shown.

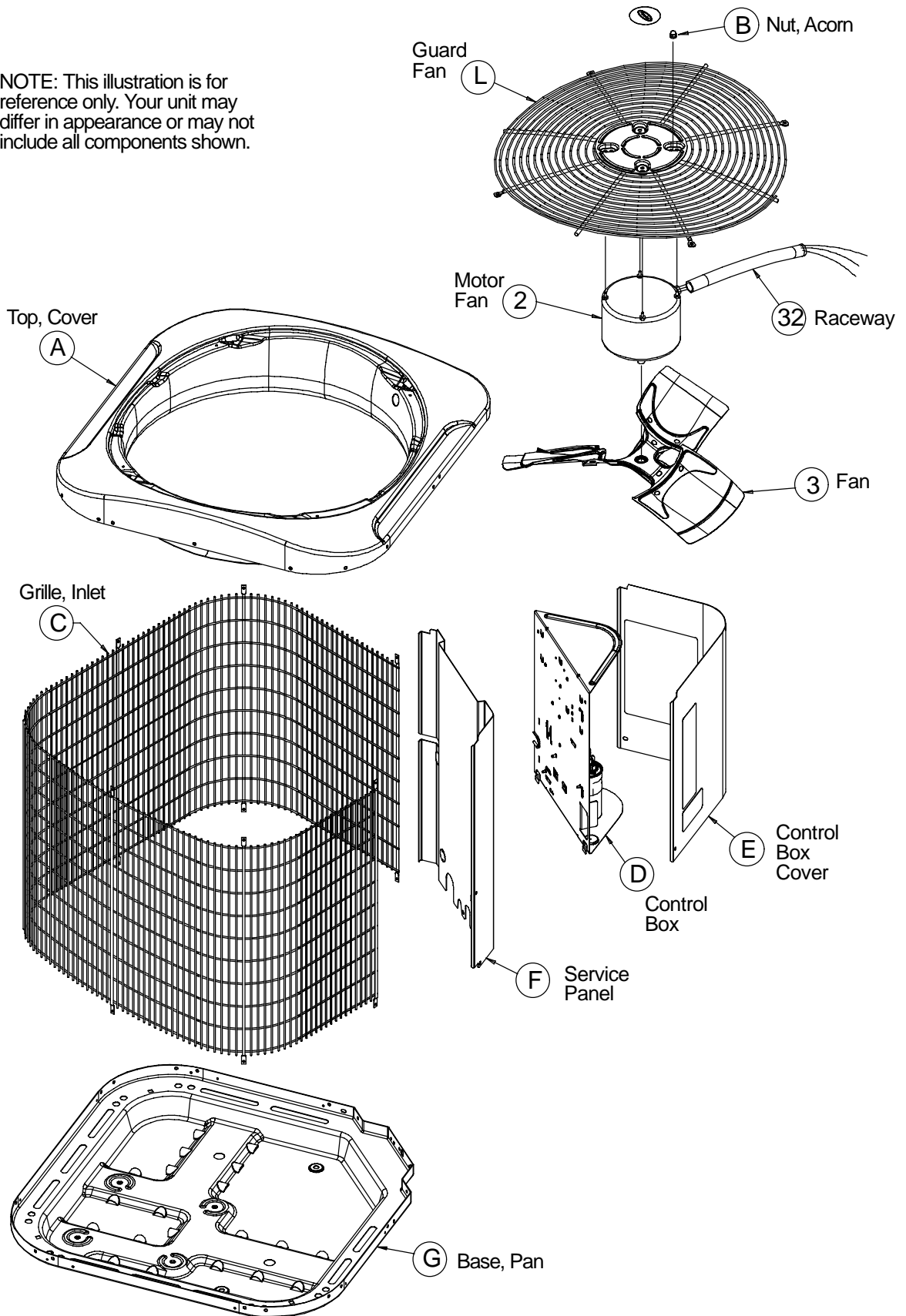

NOTE: This illustration is for reference only. Your unit may differ in appearance or may not include all components shown.

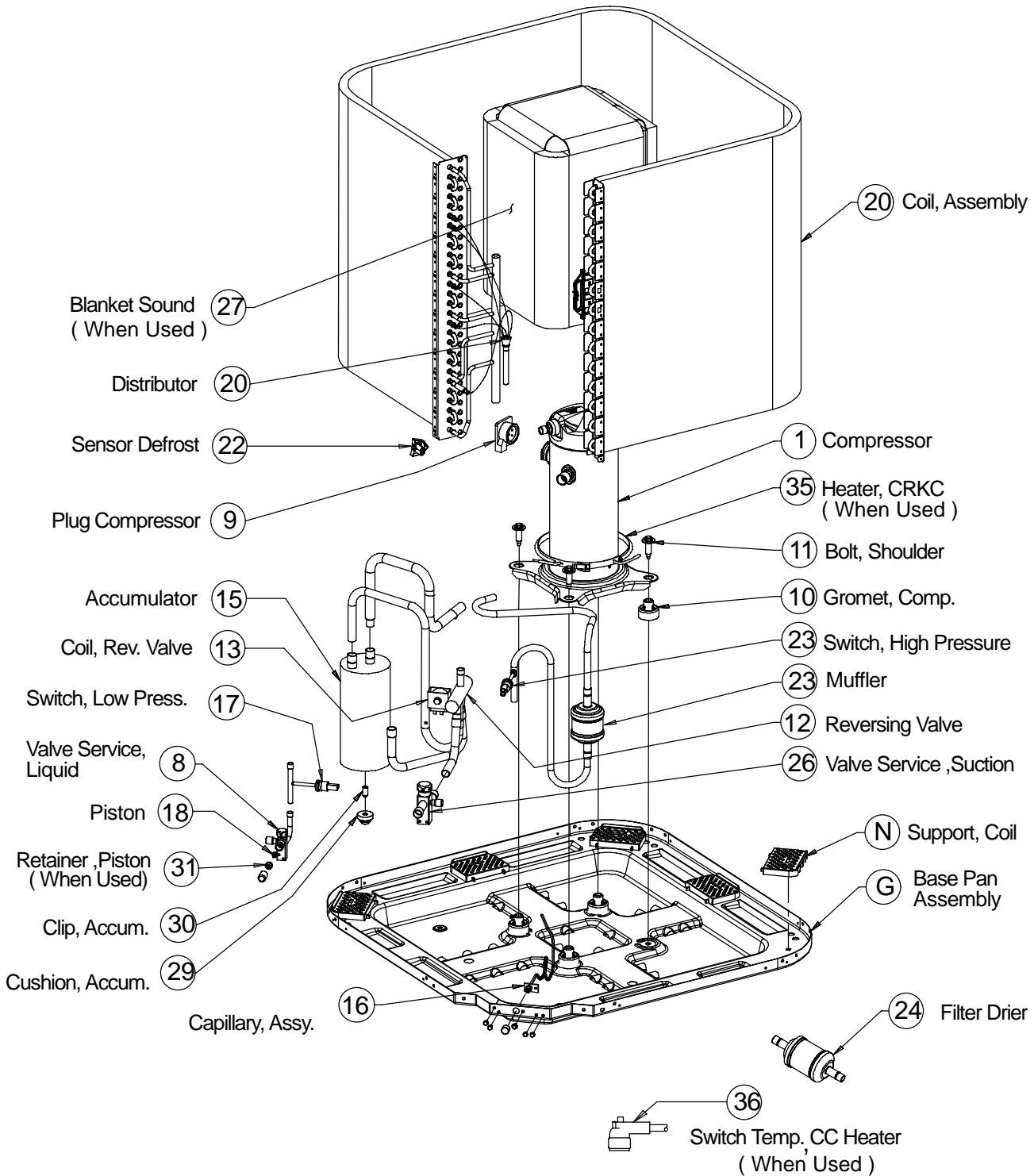

NOTE: This illustration is for reference only. Your unit may differ in appearance or may not include all components shown.

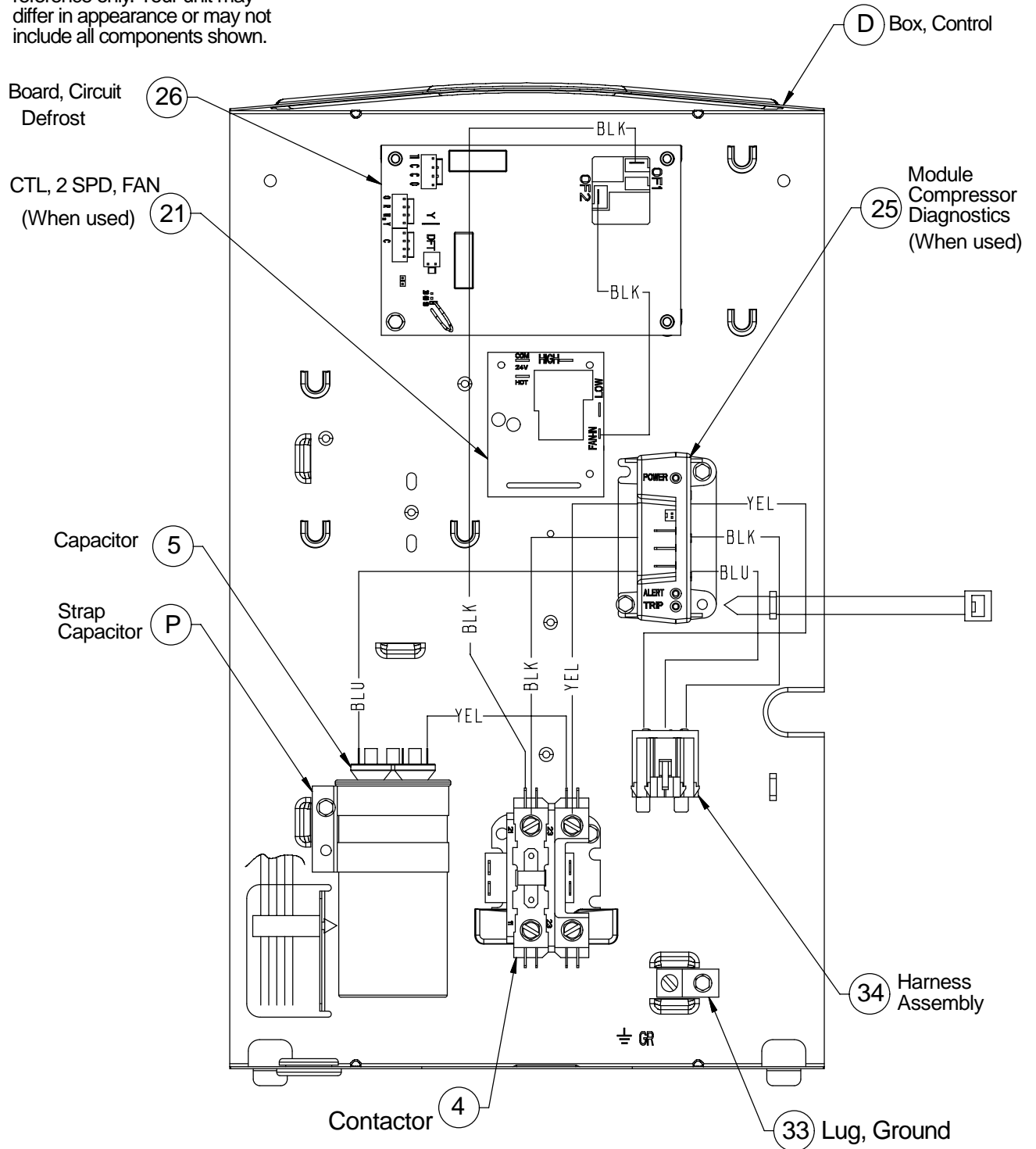

N4H3 PARTS LIST																
KEY NO.	DESCRIPTION	PART NO.	N4H318AKA100	N4H318GKA100	N4H324AKA100	N4H324GKA100	N4H330AKA100	N4H330GKA100	N4H336AKA100	N4H336GKA100	N4H342AKA100	N4H342GKA100	N4H348AKA100	N4H348GKA100	N4H360AKA100	N4H360GKA100
1	Compressor	ZR16K4PFV130	1	1	-	-	-	-	-	-	-	-	-	-	-	-

OUTDOOR UNIT MODEL NUMBER IDENTIFICATION GUIDE (single phase)											
Digit Position:	1	2	3	4	5, 6	7	8	9	10	11	12
Example Part Number:	N	4	H	3	18	A	K	A	1	0	0
<p>N = Non-Branded</p> <p>H = Heil BRANDING</p> <p>T = Tempstar BRANDING</p> <p>H = Arcoaire BRANDING</p> <p>C = Comfortmaker BRANDING</p> <p>H = Airquest BRANDING</p> <p>C = Keeprite BRANDING</p> <p>C = Kenmore BRANDING</p> <p>H = Kenmore BRANDING</p> <p>T = Kenmore BRANDING</p> <p>H = ICP Commercial BRANDING</p>											
<p>2 = R-22</p> <p>4 = R-410A REFRIGERANT</p>											
<p>A = Air Conditioner</p> <p>H = Heat Pump TYPE</p>											
<p>3 = 13 SEER 6 = 16 SEER</p> <p>4 = 14 SEER 7 = 17 SEER</p> <p>5 = 15 SEER 8 = 18 SEER NOMINAL EFFICIENCY</p>											
<p>18 = 18,000 BTUH = 1½ tons</p> <p>24 = 24,000 BTUH = 2 tons</p> <p>30 = 30,000 BTUH = 2½ tons</p> <p>36 = 36,000 BTUH = 3 tons</p> <p>42 = 42,000 BTUH = 3½ tons</p> <p>48 = 48,000 BTUH = 4 tons</p> <p>60 = 60,000 BTUH = 5 tons NOMINAL CAPACITY</p>											
<p>A = Standard Grille</p> <p>G = Coil Guard Grille FEATURES</p>											
<p>K = 208/230-1-60 VOLTAGE</p>											
Sales Code											
Engineering Revision											
Extra Digit											
Extra Digit											

ACCESSORIES PART NUMBER IDENTIFICATION GUIDE								
Digit Position:	1	2	3	4	5	6, 7	8, 9	
Example Part Number:	N	A	S	A	0	01	CH	
N = Non-Branded	BRANDING							
A = Accessory	PRODUCT GROUP							
S = Split System (AC & HP)	KIT USAGE							
A = Original								
B = 2nd Generation				MAJOR SERIES				
0 = Generic or Not Applicable								
2 = R-22								
4 = R-410A				REFRIGERANT				
Product Identifier Number								
AC = Anti-Cycle Timer	LA = Low Ambient	SC = Start Component	TD = Time Delay					
CH = Crankcase Heater	LS = Liq. Line Solenoid	SF = Support Feet	WS = Winter Start Control					
FS = Freeze Stat	PS = Pressure Switch	SJ = Sound Jacket						TYPE OF KIT